

# PYD

## ELECTROBOMBAS

### SERIE

# NW

### CENTRÍFUGA GAMA NORMALIZADA

CENTRIFUGE STANDARD RANGE

CENTRIFUGEUSE GAMME STANDARD

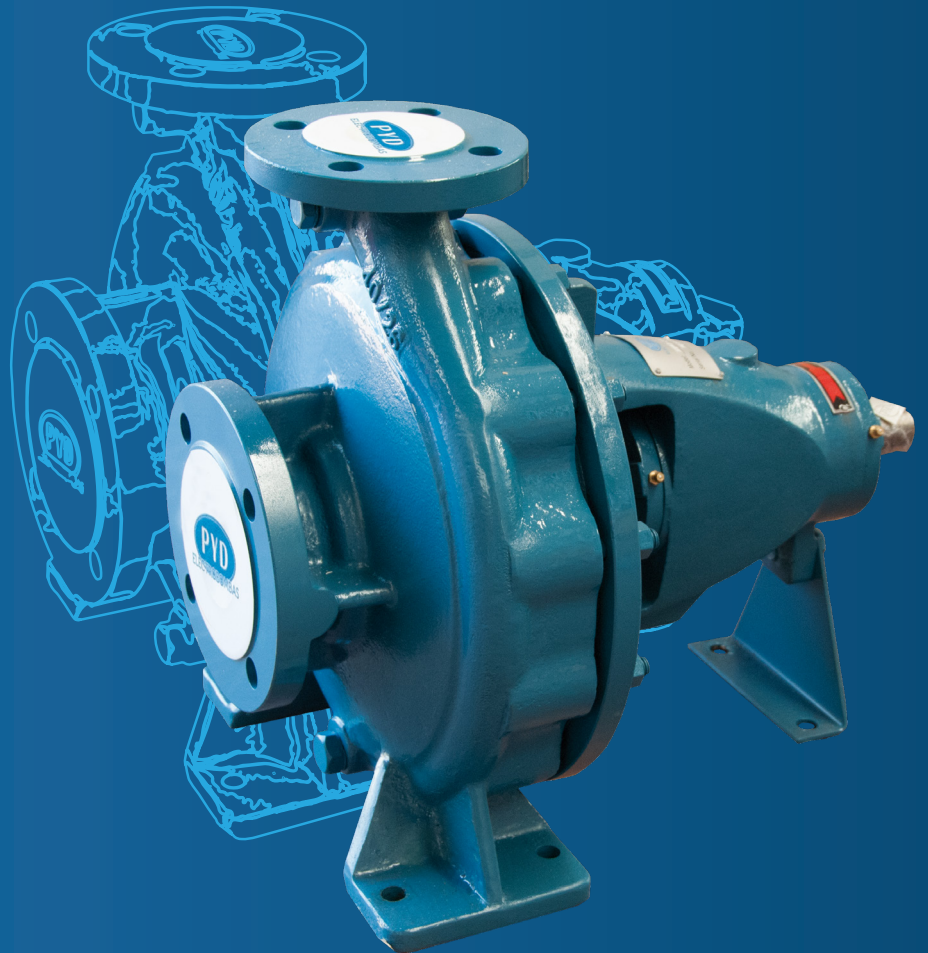

# 50 Hz

1450 RPM  
2900 RPM



## CATÁLOGO TÉCNICO

TECHNICAL CATALOGUE

CATALOGUE TECHNIQUE

## 1. DESCRIPCIÓN DESCRIPTION DESCRIPTION

Bombas centrífugas horizontales, monoetapa, con cuerpo de voluta y conexiones bridadas normalizadas conforme a UNE-EN 733 (DIN 24255) o ISO 2858/5199. Su diseño tipo back pull-out permite el desmontaje completo del conjunto rotórico (impulsor, eje y rodamientos) sin necesidad de desmontar el cuerpo de bomba ni desconectar las tuberías de aspiración e impulsión.

Horizontal, single-stage centrifugal pumps with volute casing and standardised flanged connections in accordance with UNE-EN 733 (DIN 24255) or ISO 2858/5199. Their back pull-out design allows complete disassembly of the rotor assembly (impeller, shaft and bearings) without dismantling the pump casing or disconnecting the suction and delivery pipes.

Pompes centrifuges horizontales, mono-étagées, avec corps en volute et raccordements à brides normalisés conformément à la norme UNE-EN 733 (DIN 24255) ou ISO 2858/5199. Leur conception de type "back pull-out" permet le démontage complet de l'ensemble tournant (roue, arbre et roulements) sans qu'il soit nécessaire de démonter le corps de pompe ni de déconnecter les tuyauteries d'aspiration et de refoulement.



### NORMAS

- UNE-EN 733 (DIN 24255)
- ISO 2858 / 5199

### MATERIALES

- **Cuerpo de voluta:** Hierro fundido
- **Eje de la bomba:** Acero inoxidable 420
- **Impulsor:** Acero inoxidable 304
- **Cierre mecánico\*:** Carbono/ Cerámica-Vitón  
\*Disponibile empaquetadura prensaestopas

### ÁREA DE TRABAJO

- **Caudal máx.:** 1100 m<sup>3</sup>/h (50Hz)
- **Altura máx.:** 150 m.c.a (50Hz)
- **Temperatura máx.:** 105°C
- **Presión de trabajo:** 10Bar (estándar)

### STANDARDS

- UNE-EN 733 (DIN 24255)
- ISO 2858 / 5199

### MATERIALS

- **Volute casing:** Cast iron
- **Pump shaft:** Stainless steel 420
- **Impeller:** Stainless steel 304
- **Mechanical Seal\*:** Carbon/ Ceramic-Viton  
\*Gland packing available

### WORKING RANGE

- **Max. flow:** 1100 m<sup>3</sup>/h (50Hz)
- **Max. head:** 150 m.c.a (50Hz)
- **Max. temp:** 105°C
- **Casing pressure:** 10Bar (standard)

### STANDARDS

- UNE-EN 733 (DIN 24255)
- ISO 2858 / 5199

### MATÉRIAUX

- **Corps en volute:** Fonte
- **Arbre de pompe :** Acier inoxydable 420
- **Roue :** Acier inoxydable 304
- **Garniture mécanique\*:** Carbone/Céramique - Viton  
\*Garniture à tresse disponible

### ZONE DE TRAVAIL

- **Débit max. :** 1100 m<sup>3</sup>/h (50Hz)
- **Hauteur manométrique max. :** 150 m.c.a (50Hz)
- **Temp. max.:** 105°C
- **Pression du corps :** 10Bar

**2. SELECCIÓN RÁPIDA QUICK SELECTION**

CAUDAL NOMINAL EN m³/h PARA MOTOR A 2.900 R.P.M. NOMINAL FLOW RATE IN m³/h FOR ENGINE AT 2.900 R.P.M.											
PRESIÓN NOMINAL EN METROS	12	Hp*	18	Hp*	24	Hp*	30	Hp*	36	Hp*	
	45	32-200/185	5	32-200/195	6,5	40-200/195	8	40-200/200	9	50-200/185	10
	50	32-200/195	5,5	32-200/205	7	40-200/205	8,5	40-200/205	10	50-200/195	11
	55	32-200/205	6	32-200/209	7,5	40-200/214	9	40-200/214	11	50-200/204	12
	60	32-200/208	6,5	40-200/214	9	40-200/214	9,5	40-250/225	14	40-250/231	16,5
	65	32-250/225	10,5	32-250/235	13	32-250/235	15	40-250/235	16	40-250/245	19
	70	32-250/235	11	32-250/235	14	32-250/245	16,2	40-250/245	17,5	40-250/245	19
	75	32-250/240	12,5	32-250/245	14,5	32-250/255	17,5	40-250/250	18	40-250/255	20,5
	80	32-250/255	13	32-250/245	15	32-250/260	18,5	40-250/255	19,5	40-250/264	22,5
	85	32-250/255	14	32-250/260	16,5	40-250/256	18	40-250/260	20	40-250/264	22,5
90	32-250/264	15	40-250/264	17,5	40-250/264	19	40-250/264	20,5	50-250G/255	25	

CAUDAL NOMINAL EN m³/h PARA MOTOR A 2.900 R.P.M. NOMINAL FLOW RATE IN m³/h FOR ENGINE AT 2.900 R.P.M.											
PRESIÓN NOMINAL EN METROS	42	Hp*	48	Hp*	60	Hp*	72	Hp*	84	Hp*	
	45	50-200/195	12	50-200/195	12,5	50-250/205	20	65-200/185	18	65-200/190	20,5
	50	50-200/200	12,5	50-200/204	14	50-250/205	20	65-200/195	20,5	65-200/205	24,5
	55	50-200/205	13	50-200/214	16	50-250/214	22	65-200/205	23	65-200/214	28
	60	50-200/214	15	50-200/214	16	50-250/221	22,5	65-200/214	25,5	65-200/214	28
	65	50-250/220	20	50-250/221	22	50-250G/235v	26	50-250G/235	29	65-250/225	33
	70	50-250/235	22,5	50-250/230	22,5	50-250/240	27,5	50-250G/245	32	65-250/230	34
	75	50-250/235	22,5	50-250/245	25,5	50-250/245	29	50-250G/255	35	65-250/235	35
	80	50-250G/245	24,5	50-250/245	25,5	50-250G/248	30	50-250G/255	35	65-250/245	39
	85	50-250G/250	26	50-250G/255	28	50-250G/258	33	50-250G/260	37	65-250/252	42
90	50-250G/258	26,5	50-250G/259	31	50-250G/264	35	50-315G/270	44	65-250/255	44	

CAUDAL NOMINAL EN m³/h PARA MOTOR A 2.900 R.P.M. NOMINAL FLOW RATE IN m³/h FOR ENGINE AT 2.900 R.P.M.															
PRESIÓN NOMINAL EN METROS	90	Hp*	120	Hp*	150	Hp*	180	Hp*	210	Hp*	240	Hp*	270	Hp*	
	45	65-200/195	22	80-200/190	29	80-200/200	36	100-200/195	42	100-200/198	48	100-200/205	54	125-200/200	66
	50	65-200/200	24	80-200/200	34	80-200/203	37	100-200/205	49	100-200/205	50	100-200/210	58	125-200/210	75
	55	65-200/214	28,5	80-200/210	38	80-200/214	42	100-200/210	53	100-200/214	58	100-250G/218	65	125-200/214	79
	60	65-200/214	28,5	80-200/214	40	80-250/227	47	100-250G/216	54	100-250G/220	58	100-250G/224	69	125-250G/225	80
	65	65-250/225	34,5	80-250/227	44	80-250/233	50	100-250G/224	55	100-250G/225	65	100-250G/234	80	125-250G/229	85
	70	65-250/235	37	80-250/235	45,5	80-250/240	55	100-250G/234	58	100-250G/234	75	100-250G/242	85	125-250G/235	90
	75	65-250/235	37	80-250/245	53	80-250/247	60	100-250G/240	65	100-250G/242	82	100-250G/245	90	125-250G/245	105
	80	65-250/245	40	80-250/247	54	80-250/255	60,5	100-250/245	80	100-250G/250	87	100-250G/250	95	125-250G/250	115
	85	65-250/250	42,5	80-250/255	59,5	80-250/260	67,5	100-250G/252	87	100-250G/254	92	100-250G/260	105	125-250G/256	125
90	65-250/264	45	80-250/262	64	80-250/264	70	100-250/260	97	100-250G/260	105	100-250G/264	110	125-250G/262	125	

**50-200/214**

**Ejemplo:**  
48 m³/h a 60 m.c.a.  
Bomba: 50-200  
Potencia absorbida en punto de servicio: 16 Hp

**Example:**  
48 m³/h at 60 m.c.a.  
Pump: 50-200  
Power absorbed at duty point: 16 Hp

**Example:**  
48 m³/h à 60 m.c.a.  
Pompe : 50-200  
Puissance absorbée au point de fonctionnement : 16 Hp

**Hp\* = potencia absorbida en el punto de trabajo.**  
Hp\* = power absorbed at the operating point.

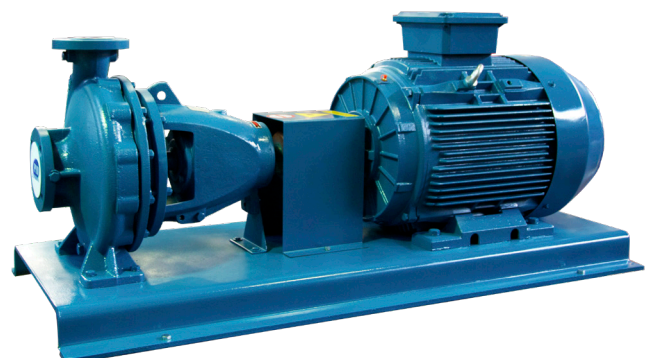

### 3. CODIFICACIÓN CODING CODAGE

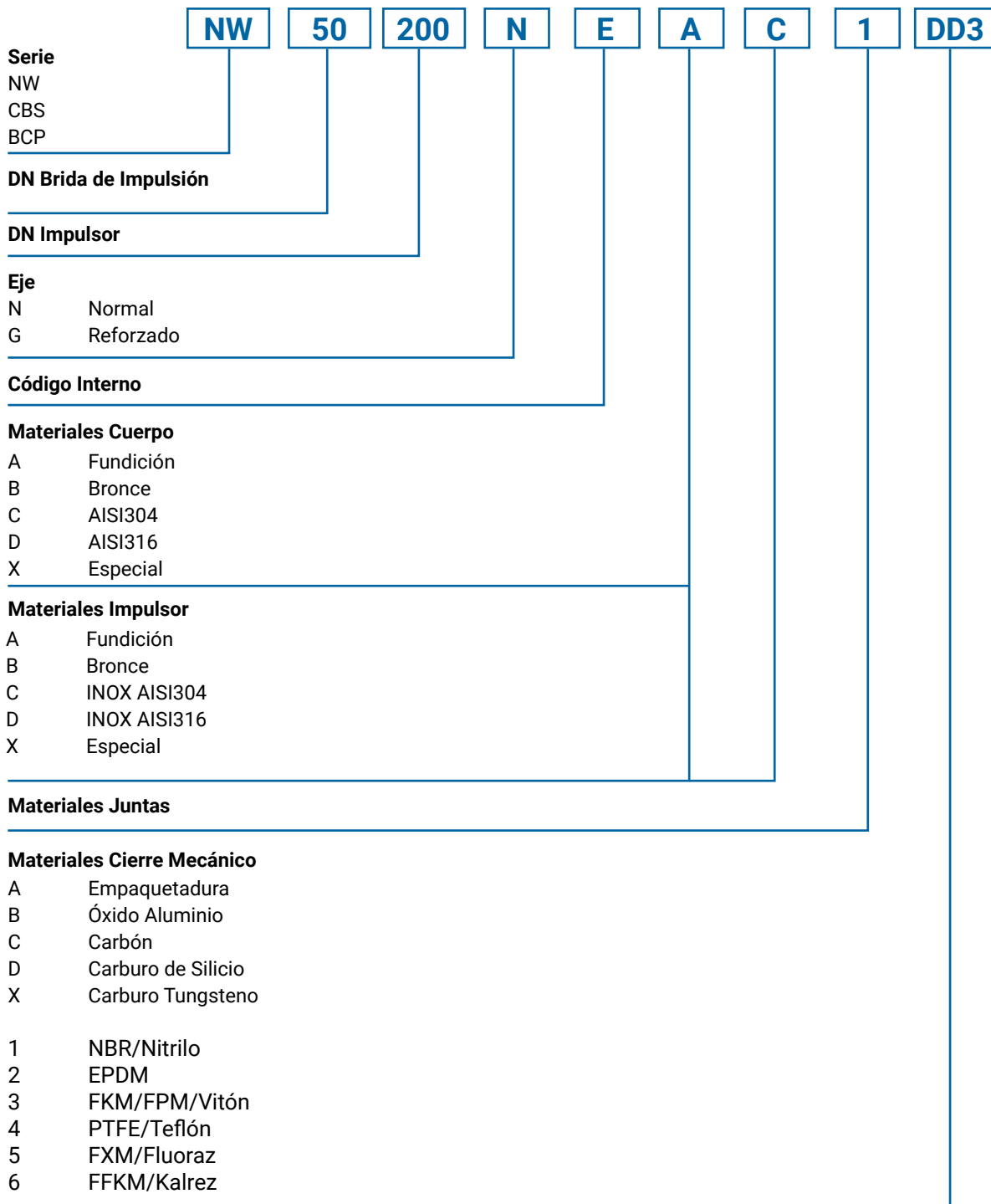

**\*Eje reforzado:**

Los modelos identificados con la letra "G" incorporan un eje reforzado y componentes estructurales sobredimensionados con el fin de incrementar su resistencia mecánica y durabilidad en condiciones de trabajo exigentes.

Como consecuencia de estas modificaciones constructivas, algunas dimensiones externas (longitud de eje, posición de apoyos, alineación de acoplamiento, etc.) pueden diferir respecto a modelos estándar u otros equivalentes del mercado conforme a norma UNE-EN 733. Se recomienda verificar siempre las cotas críticas antes de realizar cualquier integración mecánica o sustitución.

### 3. CODIFICACIÓN CODING CODAGE

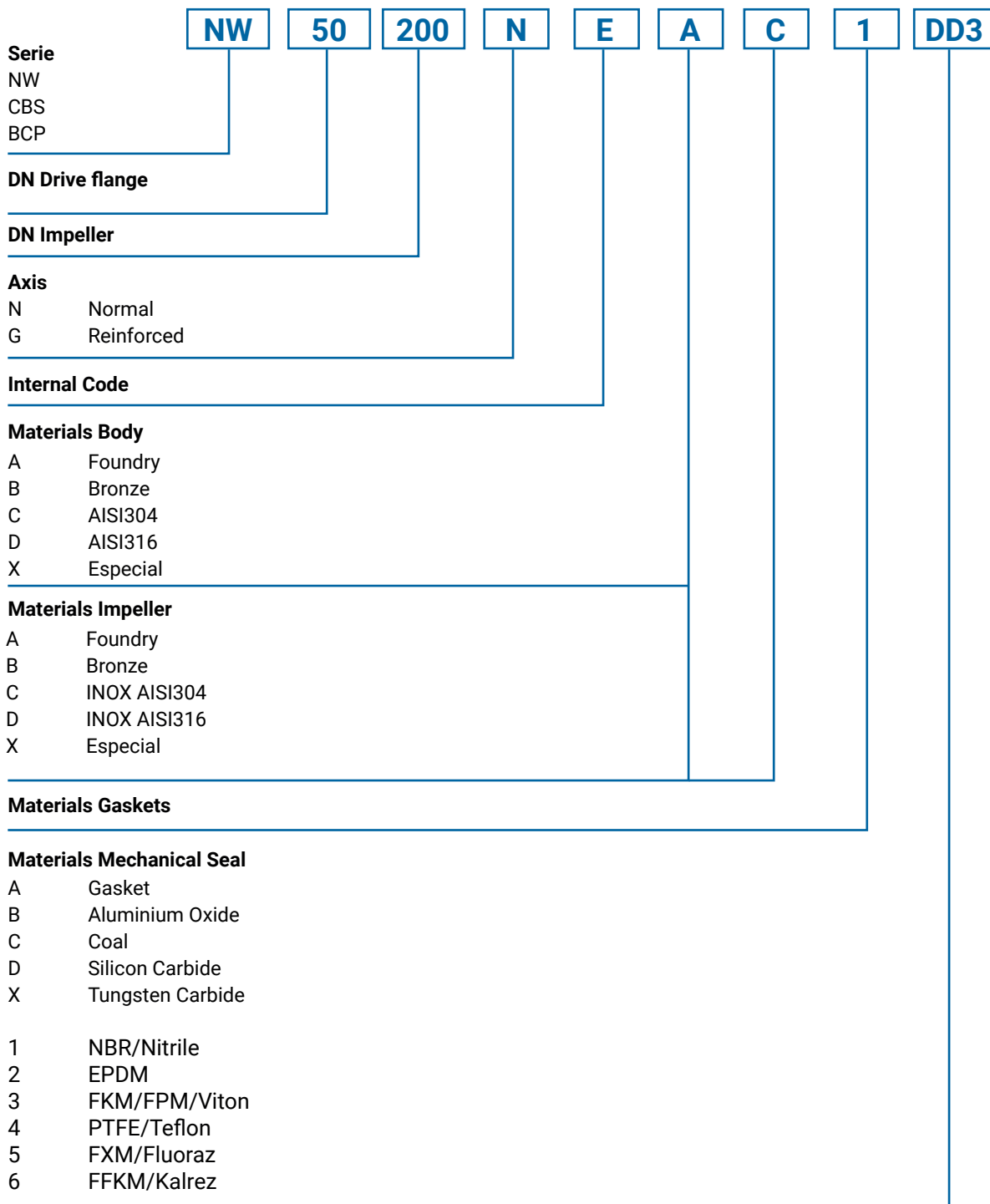

**\*Reinforced shaft:**

The models identified with the letter “G” incorporate a reinforced shaft and oversized structural components in order to increase their mechanical resistance and durability in demanding working conditions.

As a consequence of these constructive modifications, some external dimensions (shaft length, position of supports, coupling alignment, etc.) may differ from standard models or other equivalent models on the market according to UNE-EN 733 standard. It is always recommended to check the critical dimensions before carrying out any mechanical integration or replacement.

### 3. CODIFICACIÓN CODING CODAGE

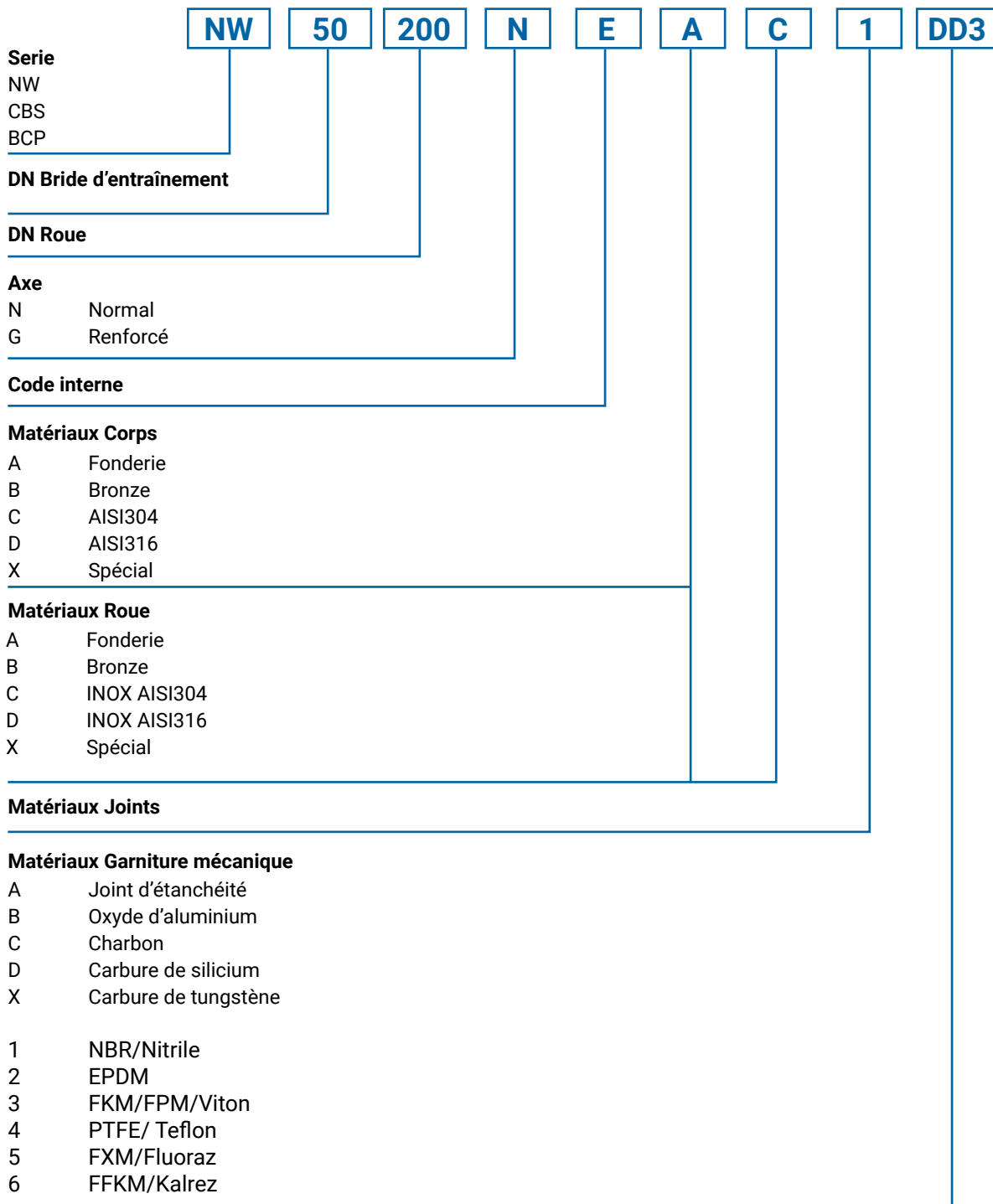

**\*Arbre renforcé**

Les modèles identifiés par la lettre « G » intègrent un arbre renforcé ainsi que des composants structurels surdimensionnés afin d'augmenter leur résistance mécanique et leur durabilité dans des conditions de travail exigeantes.

En conséquence de ces modifications constructives, certaines dimensions extérieures (longueur de l'arbre, position des supports, alignement de l'accouplement, etc.) peuvent différer des modèles standards ou d'autres modèles équivalents sur le marché conformes à la norme UNE-EN 733. Il est toujours recommandé de vérifier les dimensions critiques avant toute intégration mécanique ou opération de remplacement.

4. DIMENSIONES DIMENSIONS

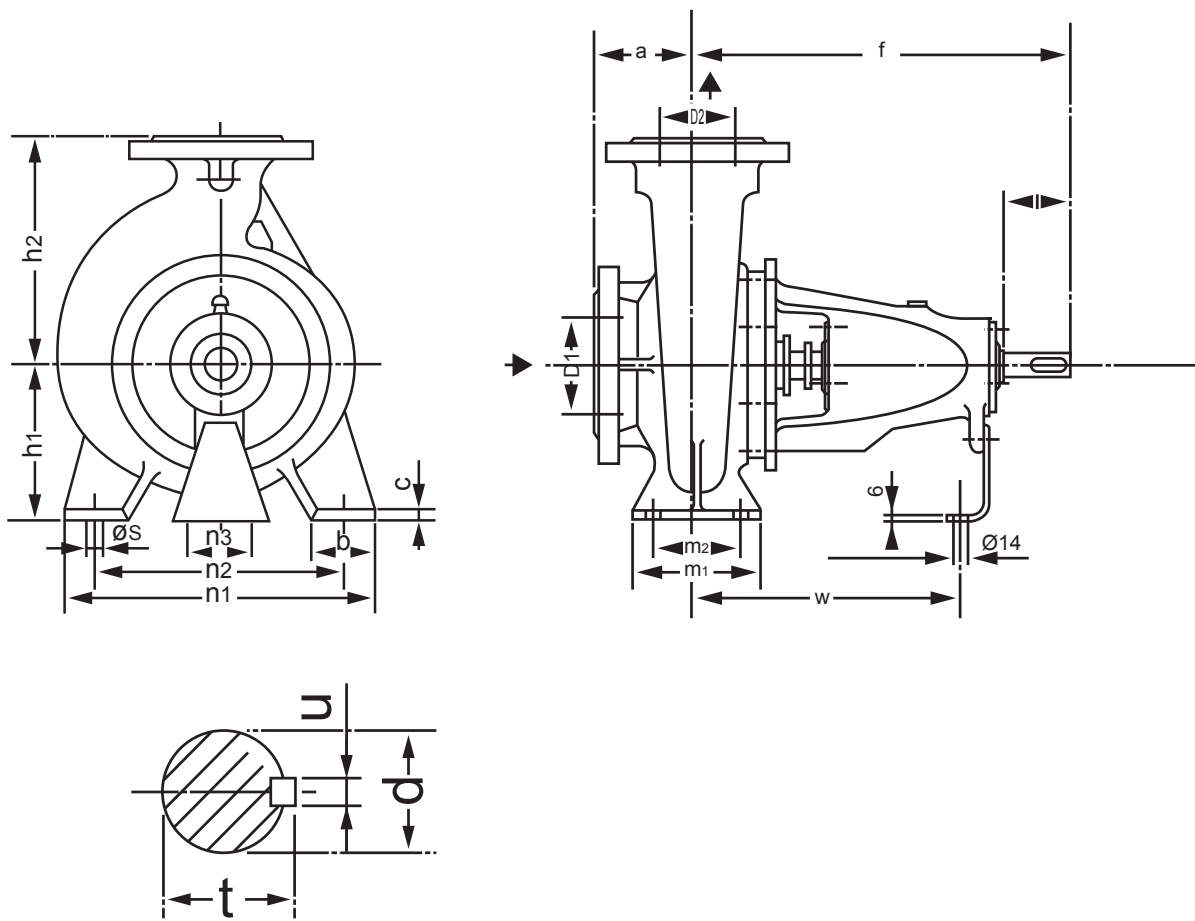

(Unit: mm)

Modelo Model	Bearing inside	BOMBA PUMP								SOPORTE FOOT						EJE SHAFT				Norma Standard	Peso Weight kg	
		DN1	DN2	a	f	h1	h2	b	c	m1	m2	n1	n2	n3	ØS	w	d	l	t			u
NW 32/125	25	50	32	80	360	112	140	50	14	100	70	190	140	100	14	267	24	50	27	8	EN733	30
NW 32/160	25	50	32	80	360	132	160	50	14	100	70	240	190	100	14	267	24	50	27	8	EN733	35
NW 32/200	25	50	32	80	360	160	180	50	14	100	70	240	190	110	14	267	24	50	27	8	EN733	47
NW 32/250	25	50	32	100	360	180	225	65	14	125	95	320	250	110	14	267	24	50	27	8	EN733	60
NW 40/125	25	65	40	80	360	112	140	50	14	100	70	210	160	100	14	267	24	50	27	8	EN733	31
NW 40/160	25	65	40	80	360	132	160	50	14	100	70	240	190	100	14	267	24	50	27	8	EN733	37
NW 40/200	25	65	40	100	360	160	180	50	14	100	70	265	212	110	14	267	24	50	27	8	EN733	48
NW 40/250	25	65	40	100	360	180	225	65	14	125	95	320	250	110	14	267	24	50	27	8	EN733	61
NW 40/315	35	65	40	125	470	200	250	65	14	125	95	345	280	110	14	342	32	80	35	10	EN733	100
NW 40/320G	45	65	40	125	526	200	250	65	14	125	95	345	280	110	14	367	42	110	45	12	-	115
NW 50/125	25	65	50	100	360	132	160	50	14	100	70	240	190	100	14	267	24	50	27	8	EN733	35
NW 50/160	25	65	50	100	360	160	180	50	14	100	70	265	212	110	14	267	24	50	27	8	EN733	40
NW 50/200	25	65	50	100	360	160	200	50	14	100	70	265	212	110	14	267	24	50	27	8	EN733	50
NW 50/250	25	65	50	100	360	180	225	65	14	125	95	320	250	110	14	267	24	50	27	8	EN733	68
NW 50/250G	35	65	50	100	470	180	225	65	14	125	95	320	250	110	14	344	32	80	35	10	-	80
NW 50/315	35	65	50	125	470	225	280	65	18	125	95	345	280	110	14	342	32	80	35	10	EN733	102
NW 50/320G	45	65	50	125	526	225	280	65	18	125	95	345	280	110	14	367	42	110	45	12	-	120
NW 65/125	25	80	65	100	360	160	180	65	14	125	95	280	212	110	14	267	24	50	27	8	EN733	41
NW 65/160	25	80	65	100	360	160	200	65	14	125	95	280	212	110	14	267	24	50	27	8	EN733	47
NW 65/200	25	80	65	105	360	180	225	65	14	125	95	320	250	110	14	267	24	50	27	8	EN733	55
NW 65/200G	35	80	65	105	465	180	225	65	14	125	95	320	250	110	14	339	32	80	35	10	-	70
NW 65/250	35	80	65	100	470	200	250	80	15	160	120	360	280	110	18	342	32	80	35	10	EN733	88
NW 65/315	35	80	65	125	470	225	280	80	18	160	120	400	315	110	18	342	32	80	35	10	EN733	115
NW 65/320G	45	80	65	125	525	225	280	80	18	160	120	400	315	110	18	367	42	110	45	12	-	130

Modelo Model	Bearing inside	BOMBA PUMP mm								SOPORTE FOOT mm							EJE SHAFT mm				Norma Standard	Peso Weight kg
		DN1	DN2	a	f	h1	h2	b	c	m1	m2	n1	n2	n3	ØS	w	d	l	t	u		
NW 80/160	25	100	80	125	360	180	225	65	14	125	95	320	250	110	14	267	24	50	27	8	EN733	53
NW 80/200	35	100	80	125	470	180	250	65	15	125	95	345	280	110	14	342	32	80	35	10	EN733	78
NW 80/250	35	100	80	125	470	200	280	80	15	160	120	400	315	110	18	342	32	80	35	10	EN733	98
NW 80/320	35	100	80	125	470	250	315	80	16	160	120	400	315	110	18	342	32	80	35	10	EN733	120
NW 80/320G	45	100	80	125	526	250	315	80	16	160	120	400	315	110	18	367	42	110	45	12	-	140
NW 80/400	45	100	80	125	530	280	355	83	18	160	120	440	340	110	18	370	42	110	45	12	EN733	169
NW 100/160	35	125	100	125	470	200	250	80	15	160	120	360	280	110	18	342	32	80	35	10	EN733	87
NW 100/200	35	125	100	125	470	200	280	80	16	160	120	360	280	110	18	342	32	80	35	10	EN733	85
NW 100/250	35	125	100	140	470	225	280	80	16	160	120	400	315	110	18	342	32	80	35	10	EN733	105
NW 100/250G	45	125	100	140	526	225	280	80	16	160	120	400	315	110	18	365	42	110	45	12	-	125
NW 100/315	35	125	100	140	470	250	315	80	16	160	120	400	315	110	18	342	32	80	35	10	EN733	121
NW 100/315G	45	125	100	140	526	250	315	80	16	160	120	400	315	110	18	367	42	110	45	12	-	145
NW 100/400	45	125	100	140	530	280	355	100	20	200	150	500	400	110	23	370	42	110	45	12	EN733	176
NW 125/200	35	150	125	145	470	250	315	80	16	160	120	400	315	110	18	342	32	80	35	10	EN733	112
NW 125/250	35	150	125	140	470	250	355	80	16	160	120	400	315	110	18	342	32	80	35	10	EN733	117
NW 125/250G	-	150	125	140	524	250	355	80	16	160	120	400	315	110	18	365	42	110	45	12	-	140
NW 125/315	45	150	125	140	530	280	355	100	18	200	150	500	400	110	23	370	42	110	45	12	EN733	160
NW 125/400	45	150	125	160	530	315	400	100	18	200	150	500	400	110	23	370	42	110	45	12	EN733	193
NW 125/500	-	150	125	160	670	355	450	100	25	200	150	550	450	140	M20	500	48	110	51.5	14	ISO2858	222
NW 150/200	35	200	150	160	500	280	400	100	18	200	150	400	315	110	23	342	32	80	35	10	EN733	133
NW 150/250	45	200	150	160	530	250	355	100	18	200	150	450	350	110	23	370	42	110	45	12	EN733	163
NW 150/315	45	200	150	160	530	280	400	100	18	200	150	550	450	110	23	370	42	110	45	12	EN733	180
NW 150/400	45	200	150	160	530	315	450	100	18	200	150	550	450	110	23	370	42	110	45	12	EN733	215
NW 150/500	-	200	150	160	670	400	500	100	25	200	150	550	450	140	M20	500	48	110	51.5	14	ISO2858	382
NW 200/260	45	250	200	180	555	315	450	100	20	200	150	550	450	110	28	392	42	110	45	12	EN733	226
NW 200/320	55	250	200	180	670	315	480	120	20	220	170	600	480	110	28	505	48	110	51	14	EN733	280
NW 200/400	55	250	200	180	670	335	480	120	20	250	170	600	480	110	28	505	48	110	51	14	EN733	338
NW 200/500	-	250	200	225	885	400	580	150	28	315	250	760	630	180	M24	670	65	140	69	18	ISO2858	600
NW 250/320	55	300	250	220	691	355	520	150	26	250	200	660	510	110	28	525	48	110	51	14	EN733	370
NW 250/400	55	300	250	220	682	400	560	150	26	250	200	660	510	110	28	516	48	110	51	14	EN733	400
NW 250/500	-	300	250	225	885	450	630	150	28	315	250	760	630	180	M24	670	65	140	69	18	ISO2858	690
NW 300/400	-	350	300	250	975	450	600	180	24	315	250	760	630	180	M24	730	75	170	79.5	20	ISO2858	780

**ISO 700 5.2 DIN 2501 PN 16 GB / T1724 1.6 PN 1.6**

DN1/DN2	32	40	50	65	80	100	125	150	200	250	300	350
D1 /D2	140	150	165	185	200	220	250	285	340	405	460	520
K1 /K2	100	110	125	145	160	180	210	240	295	355	410	470
n-d1 / n-d2	4φ-18	4φ-18	4φ-18	4φ-18	8φ-18	8φ-18	8φ-18	8φ-22	12φ-22	12φ-26	12φ-26	16φ-26

5. GRÁFICO DE CURVAS CURVE GRAPH

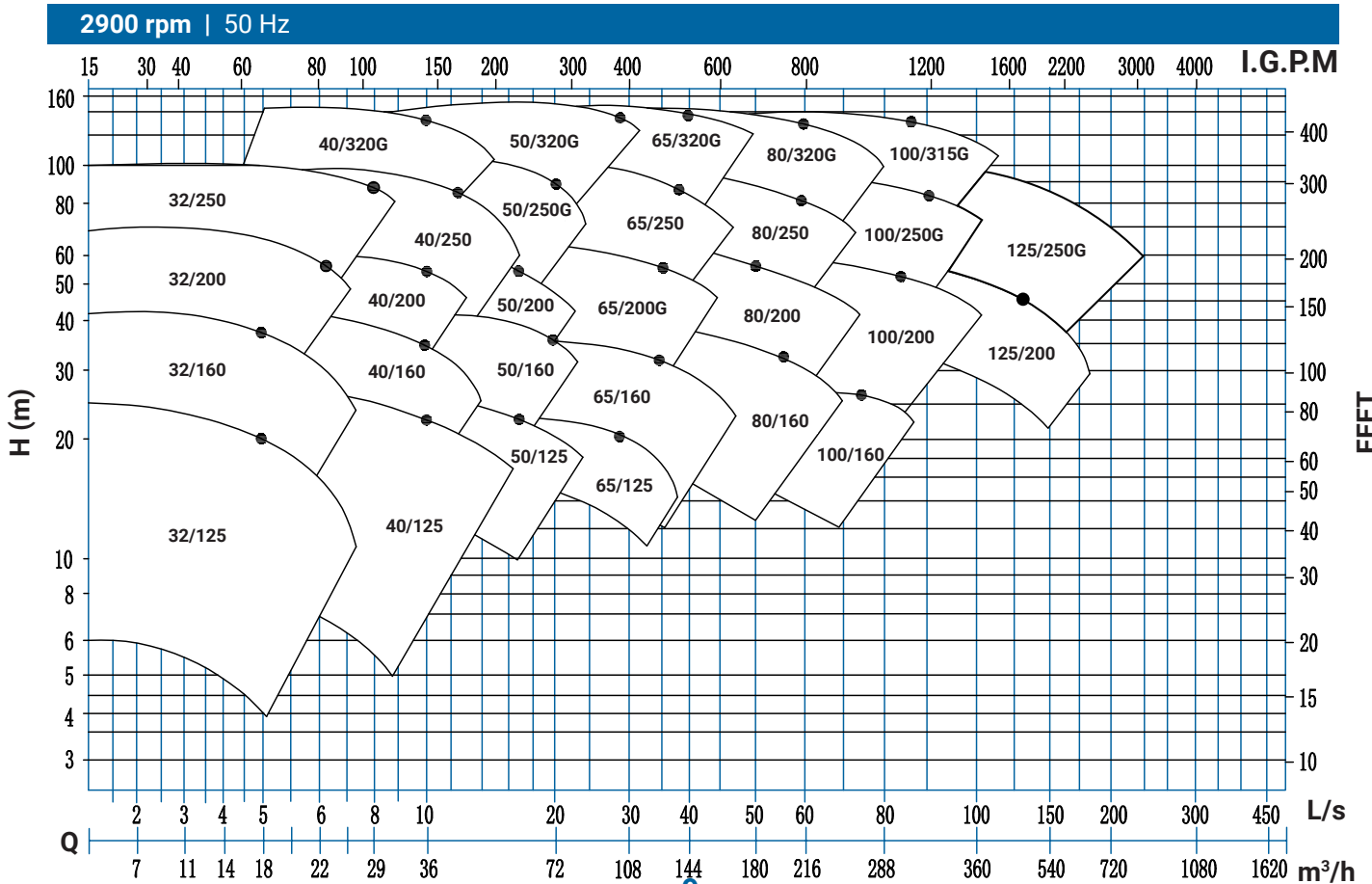
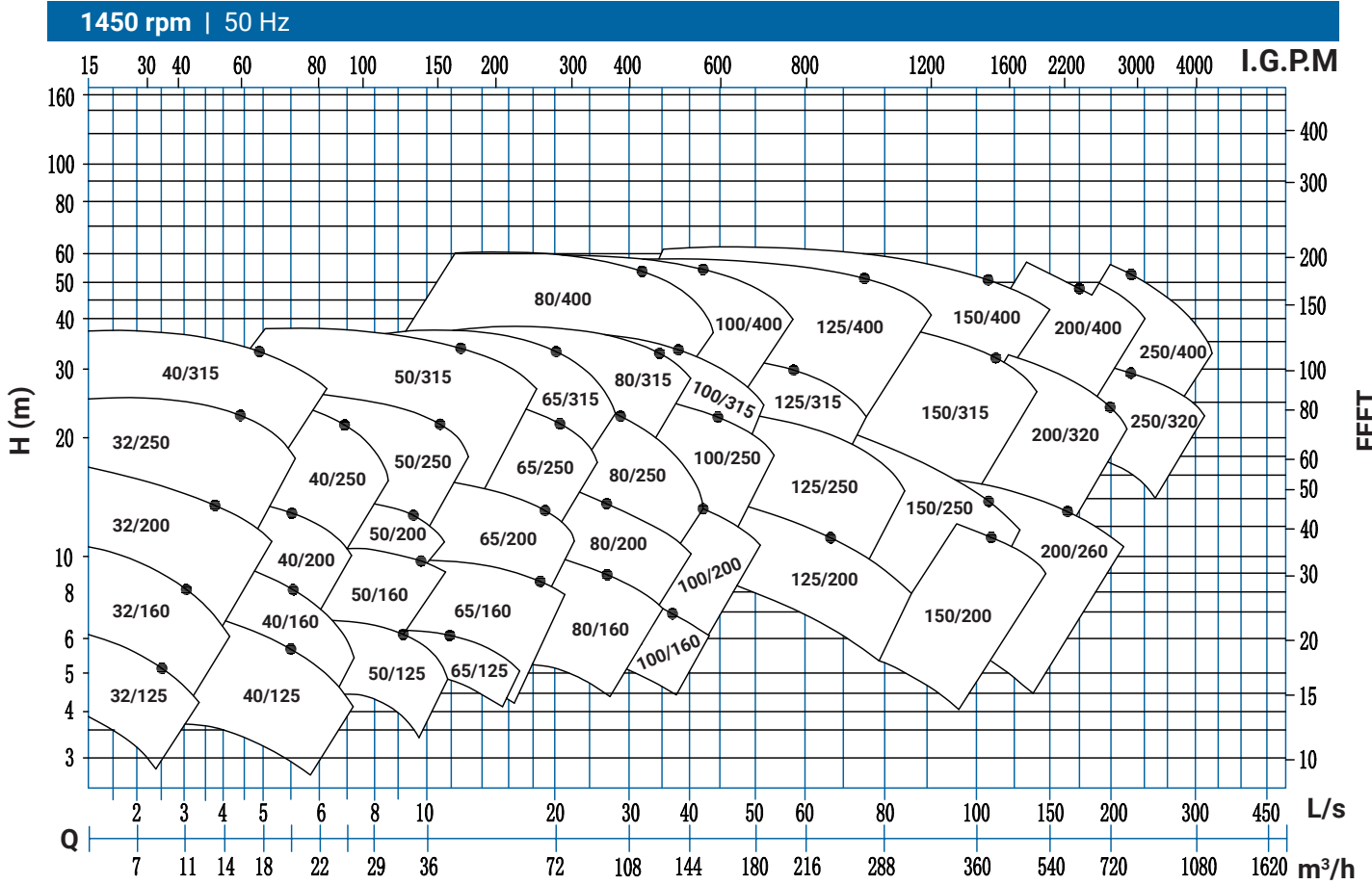

**1750 rpm | 60 Hz**

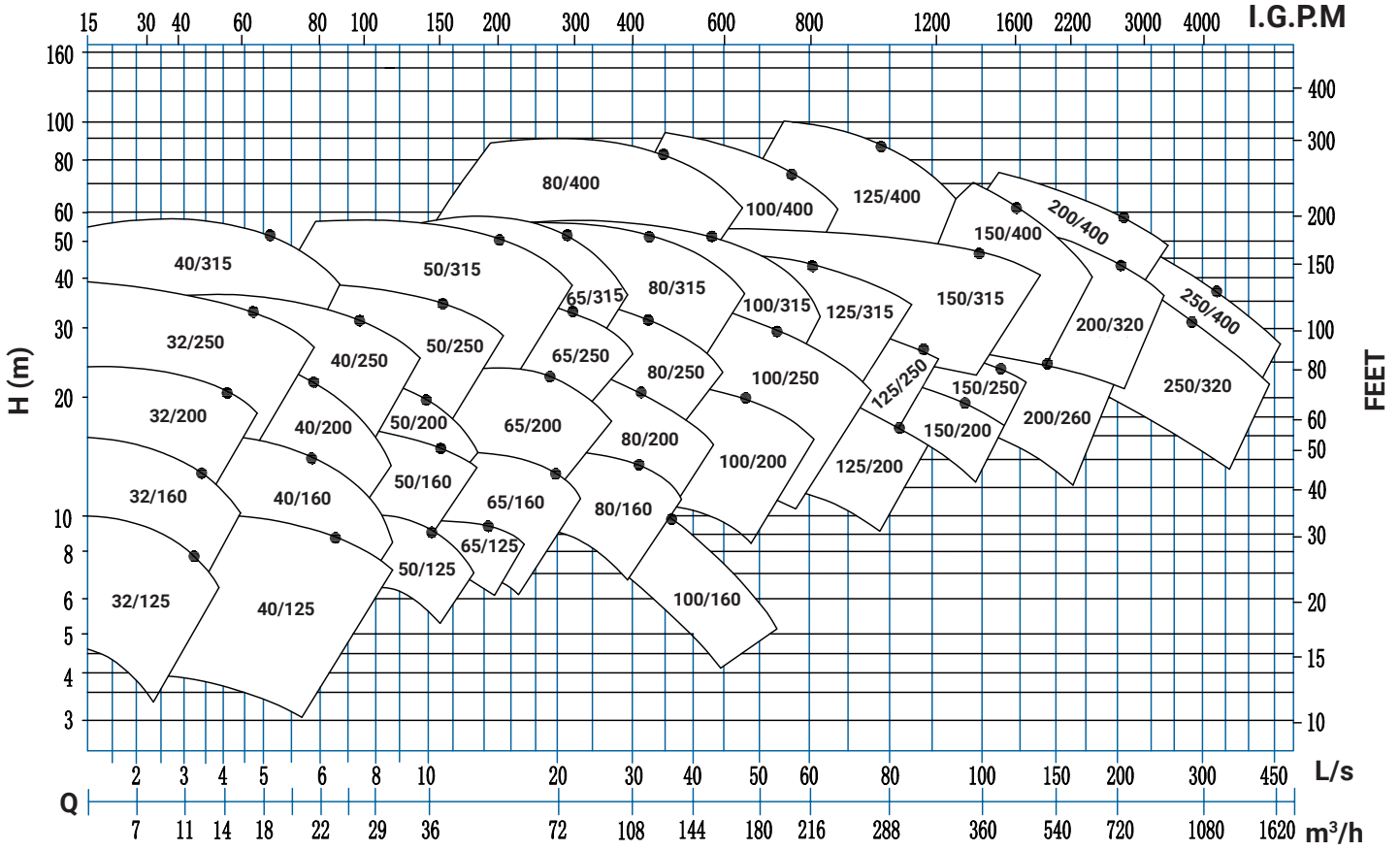

**3500 rpm | 60 Hz**

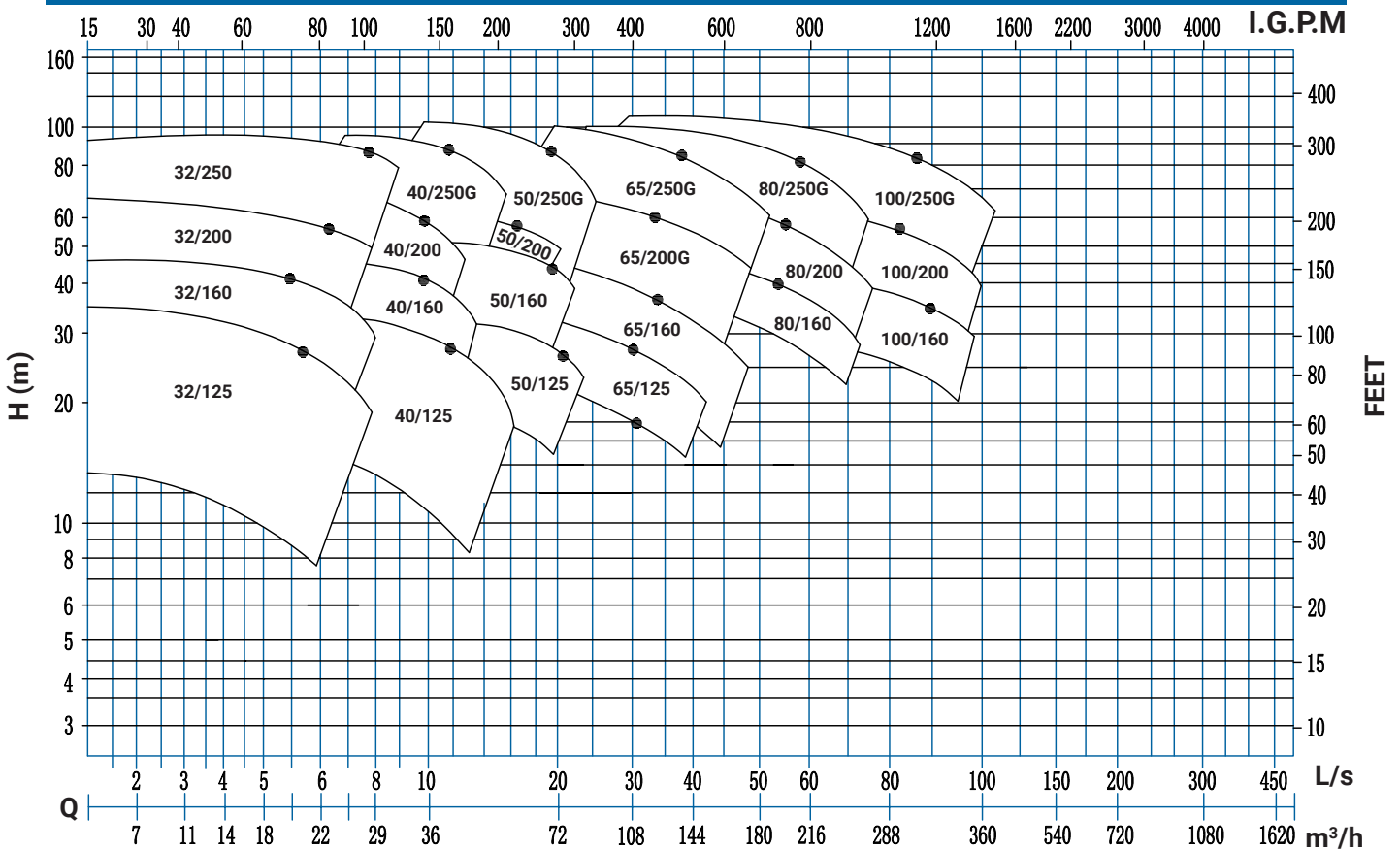

**NW32-125**  
1450 RPM

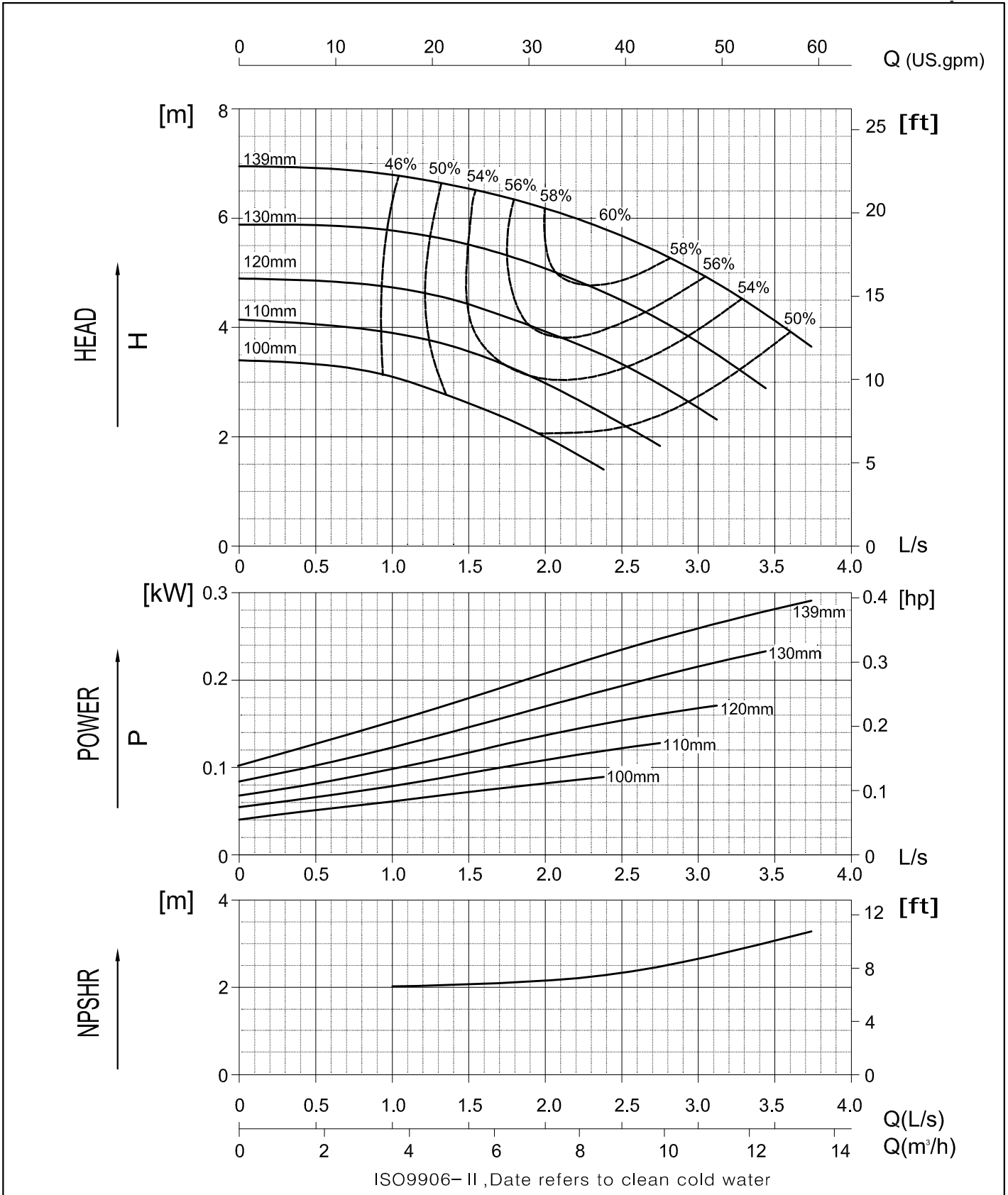

**NW32-160**  
1450 RPM

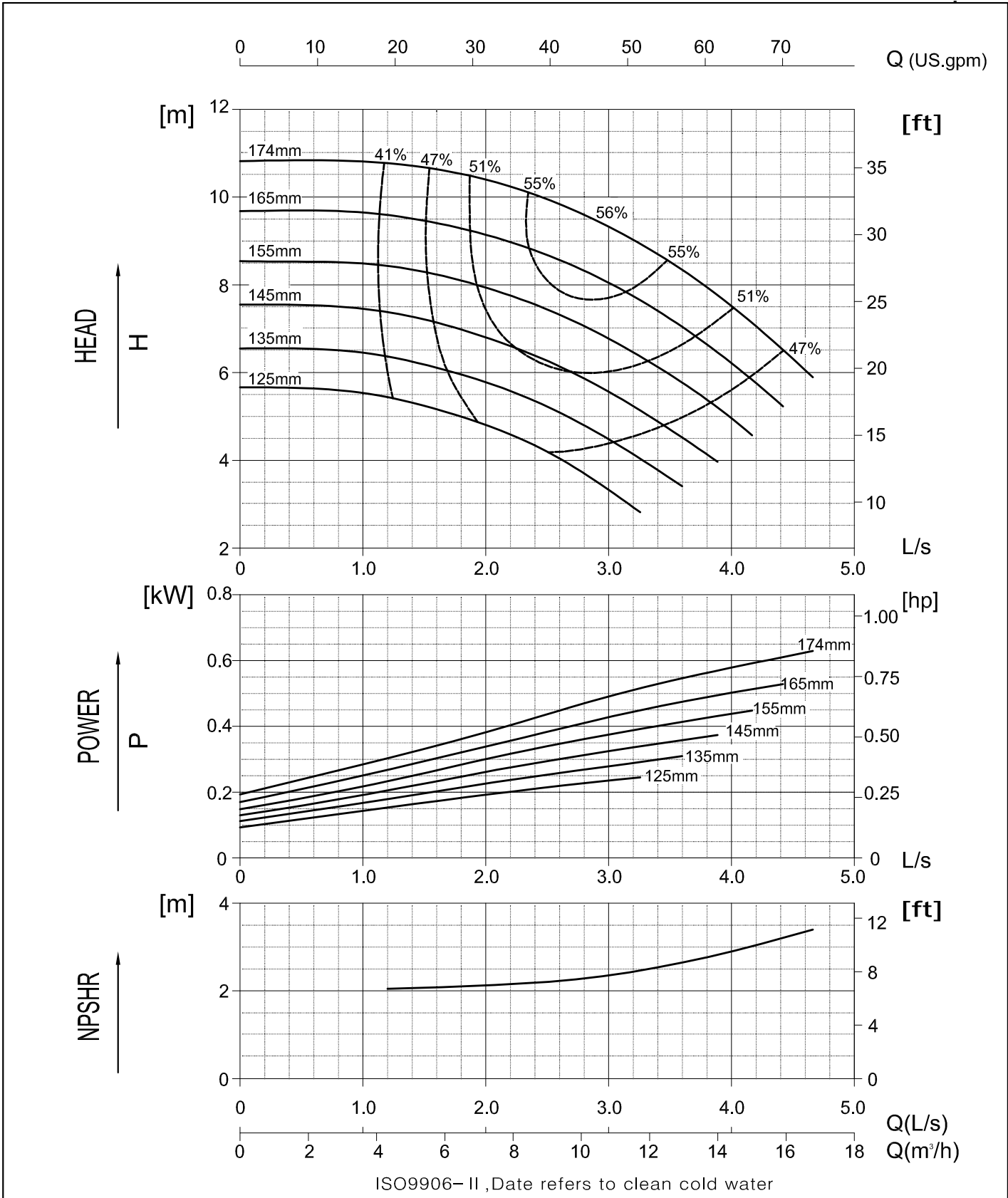

**NW32-200**  
1450 RPM

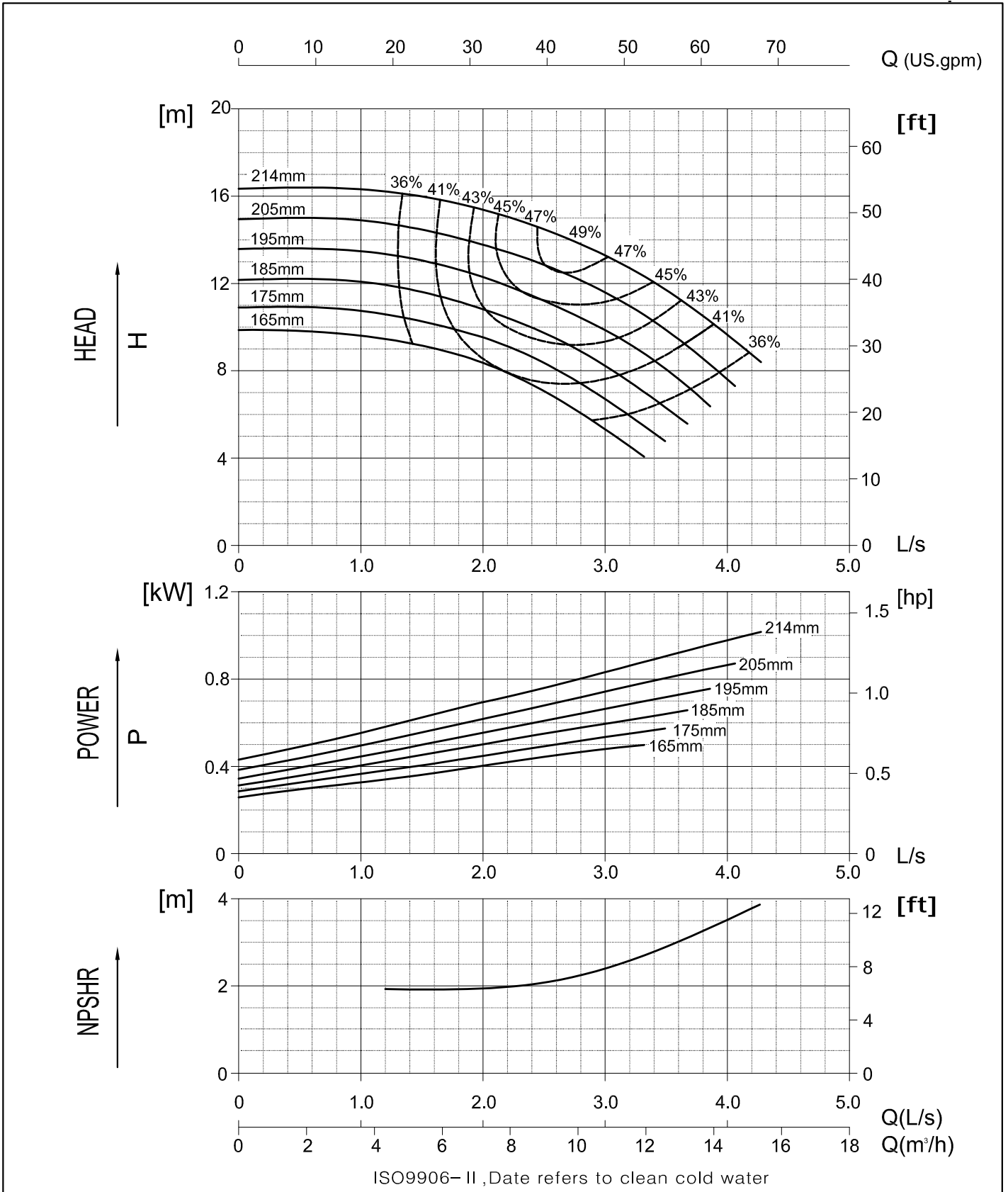

**NW32-250**  
1450 RPM

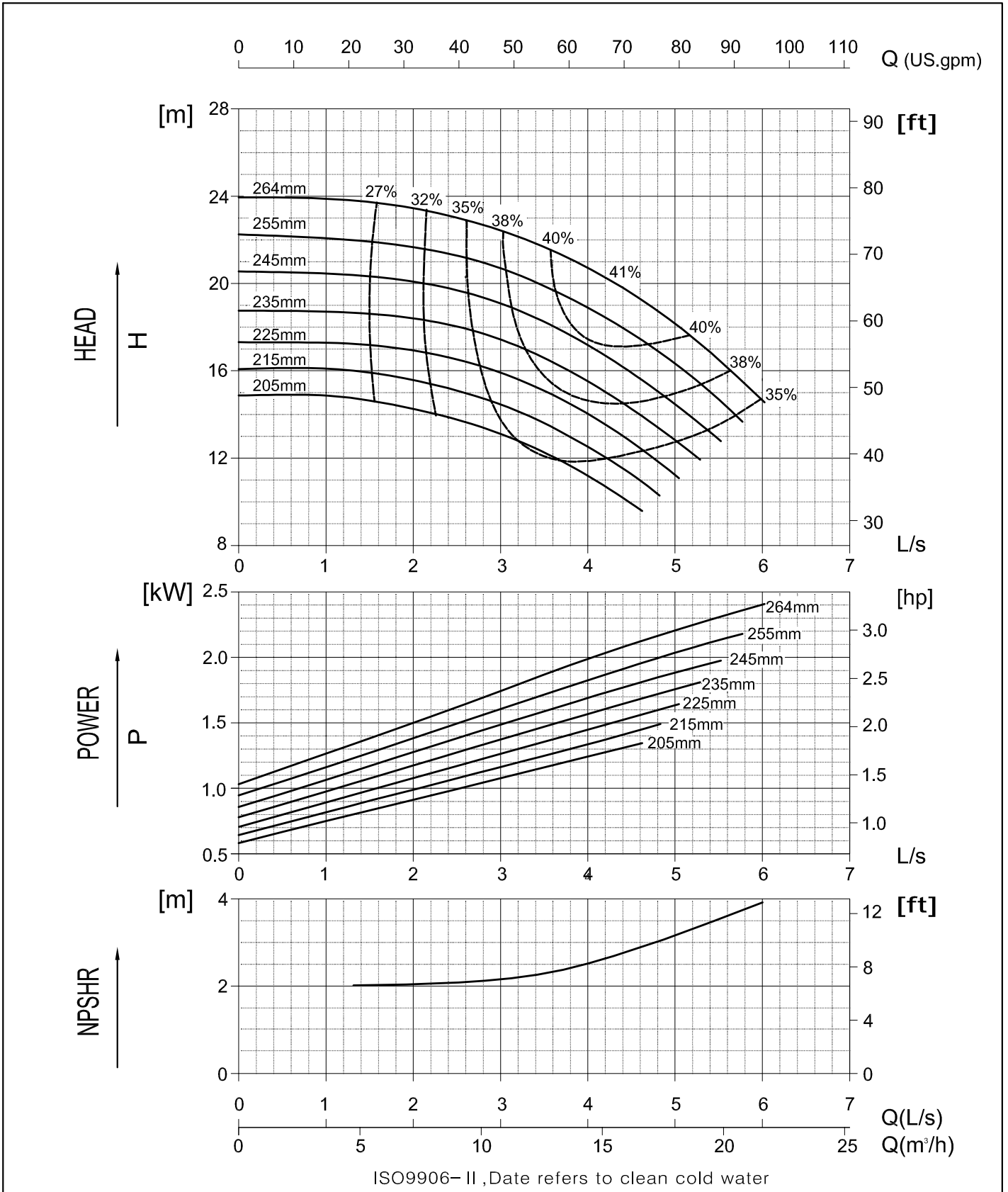

**NW40-125**  
1450 RPM

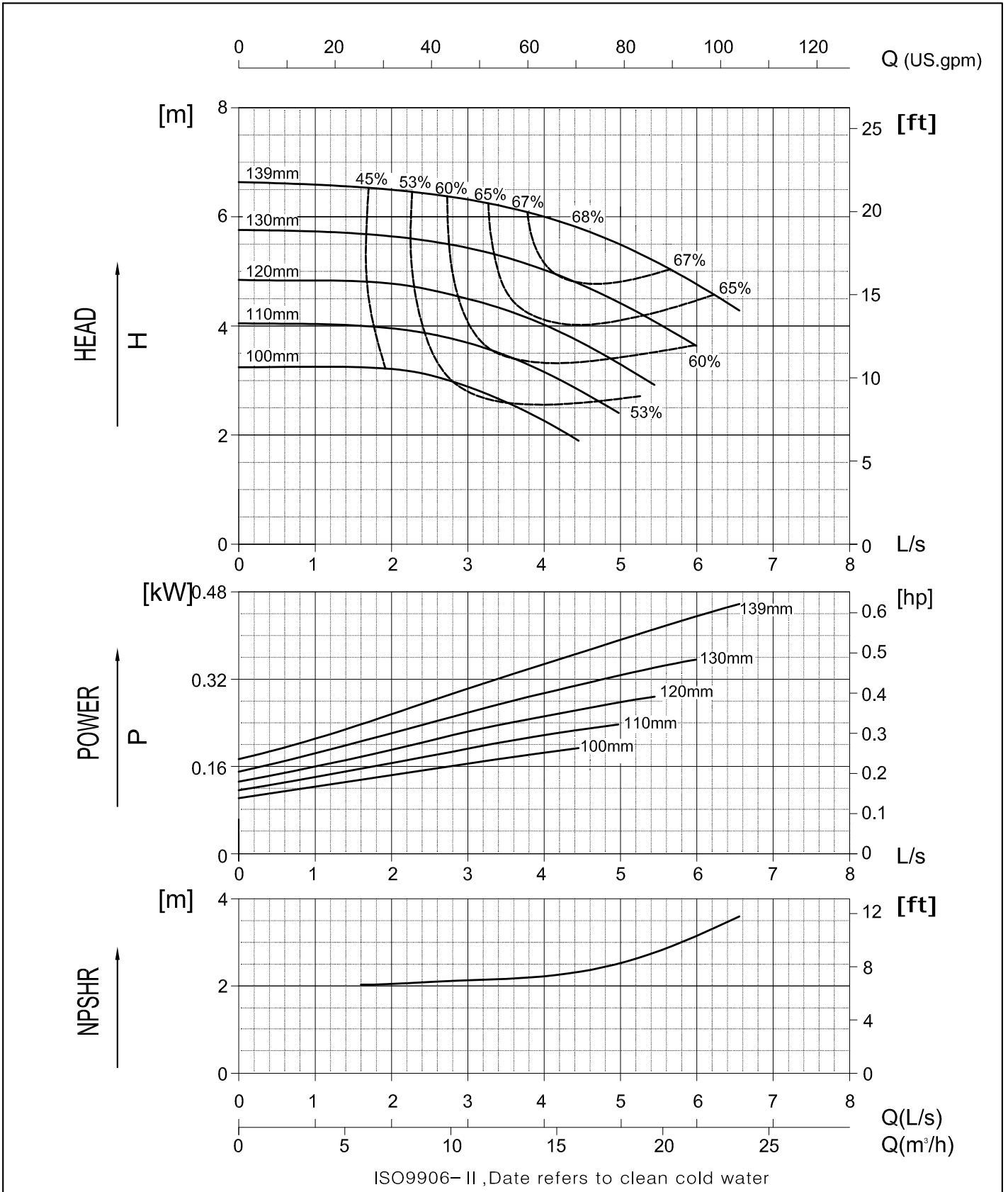

**NW40-160**  
1450 RPM

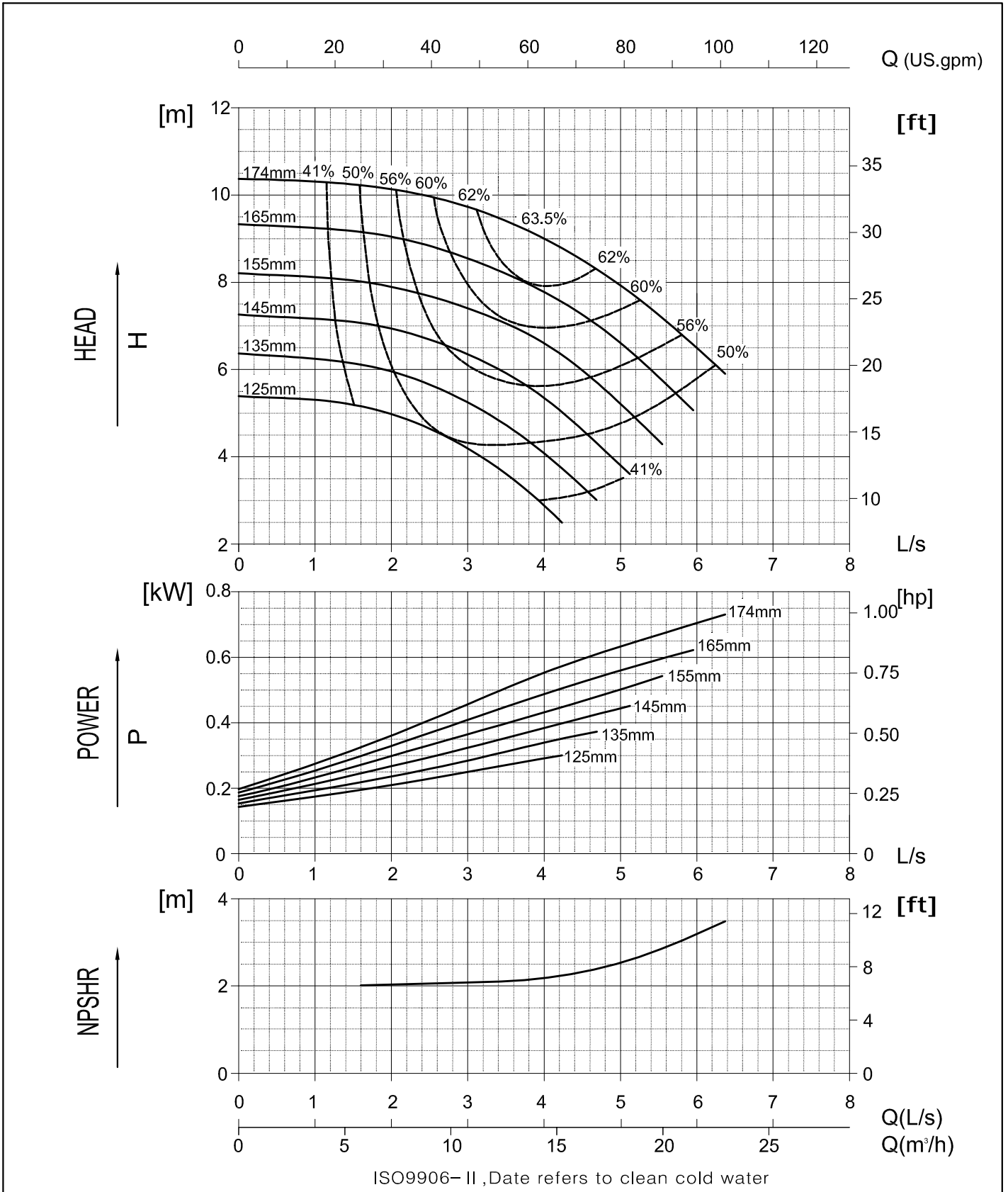

**NW40-200**  
1450 RPM

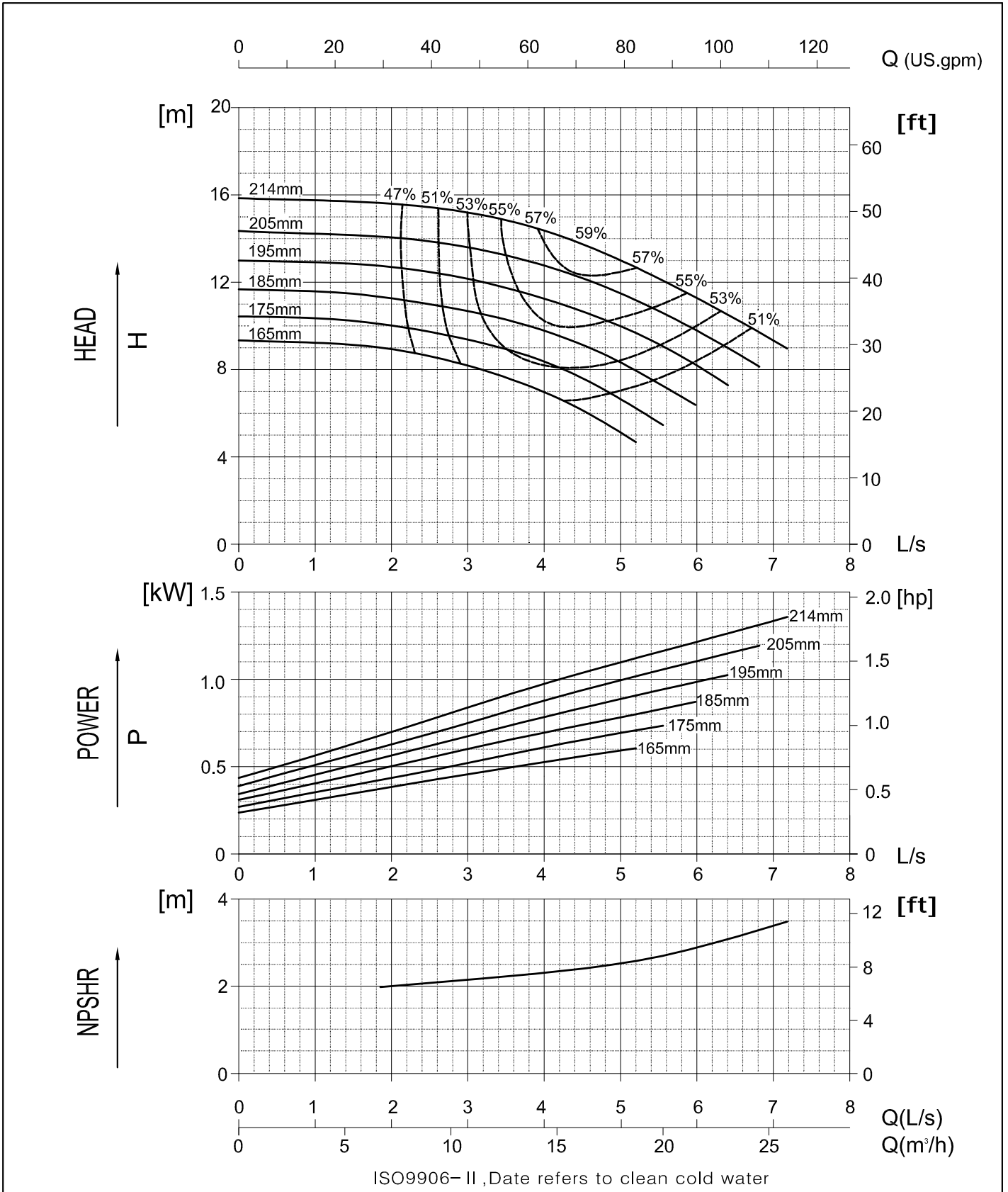

**NW40-250**  
1450 RPM

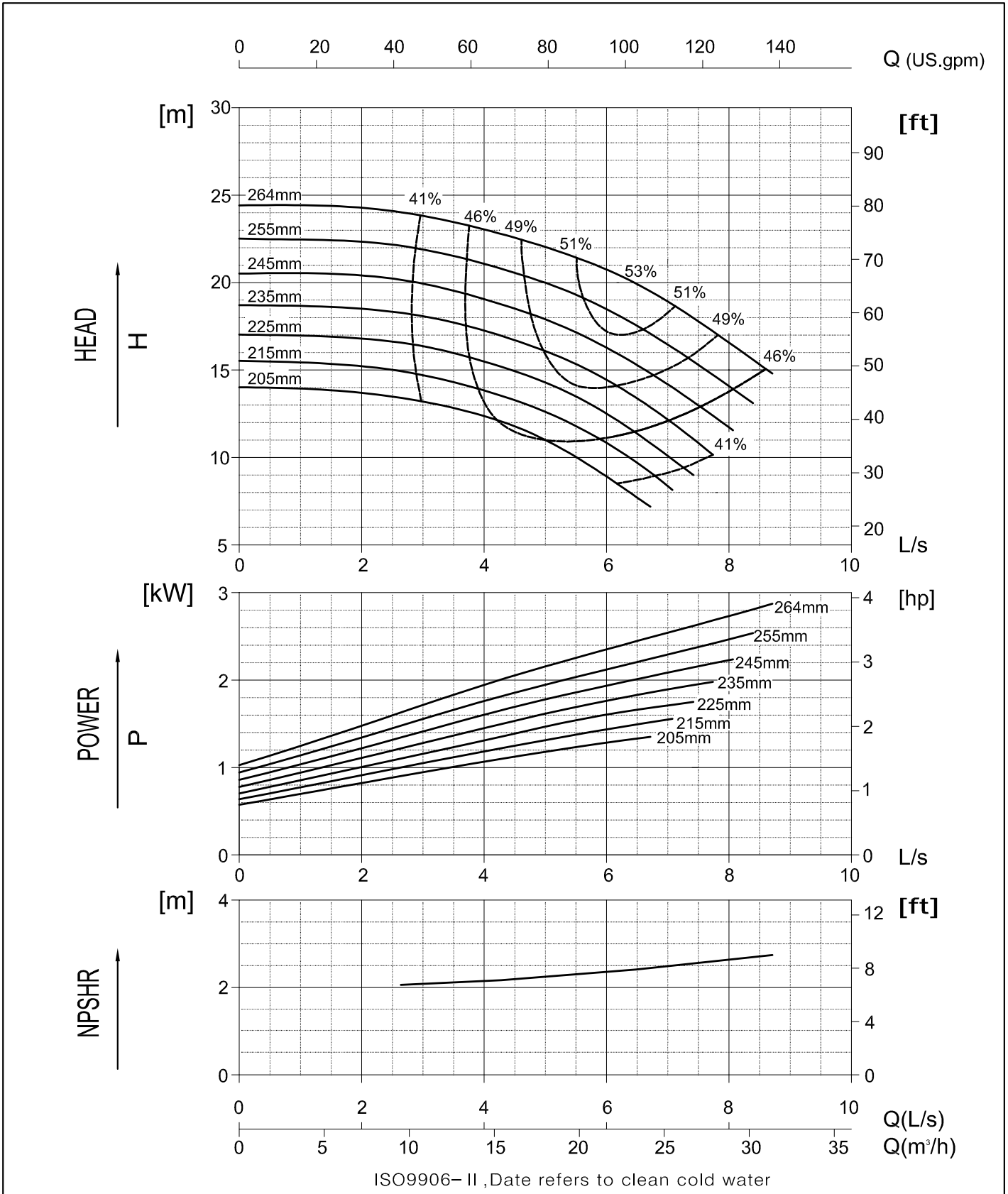

**NW40-315**  
1450 RPM

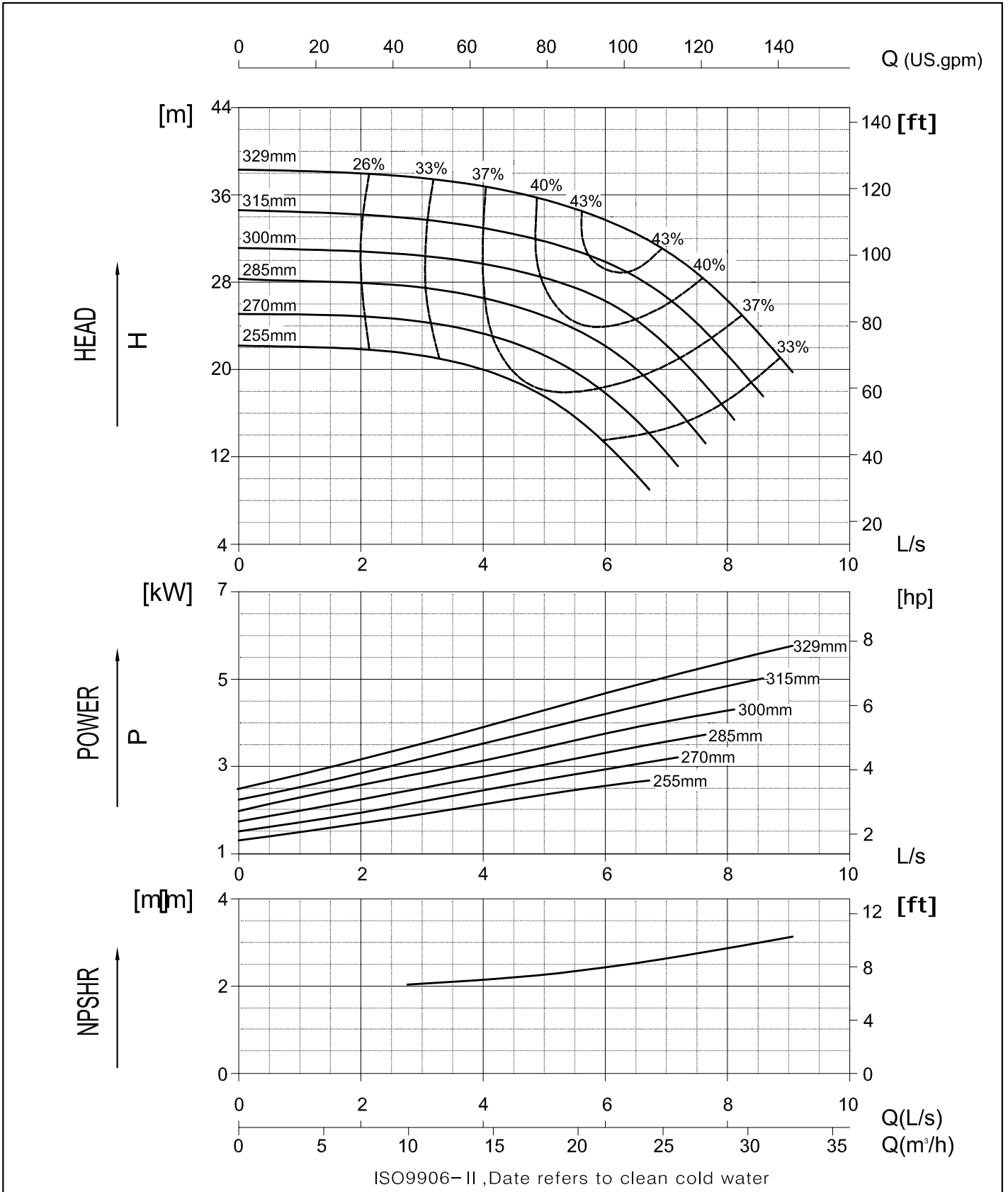

**NW50-125**  
1450 RPM

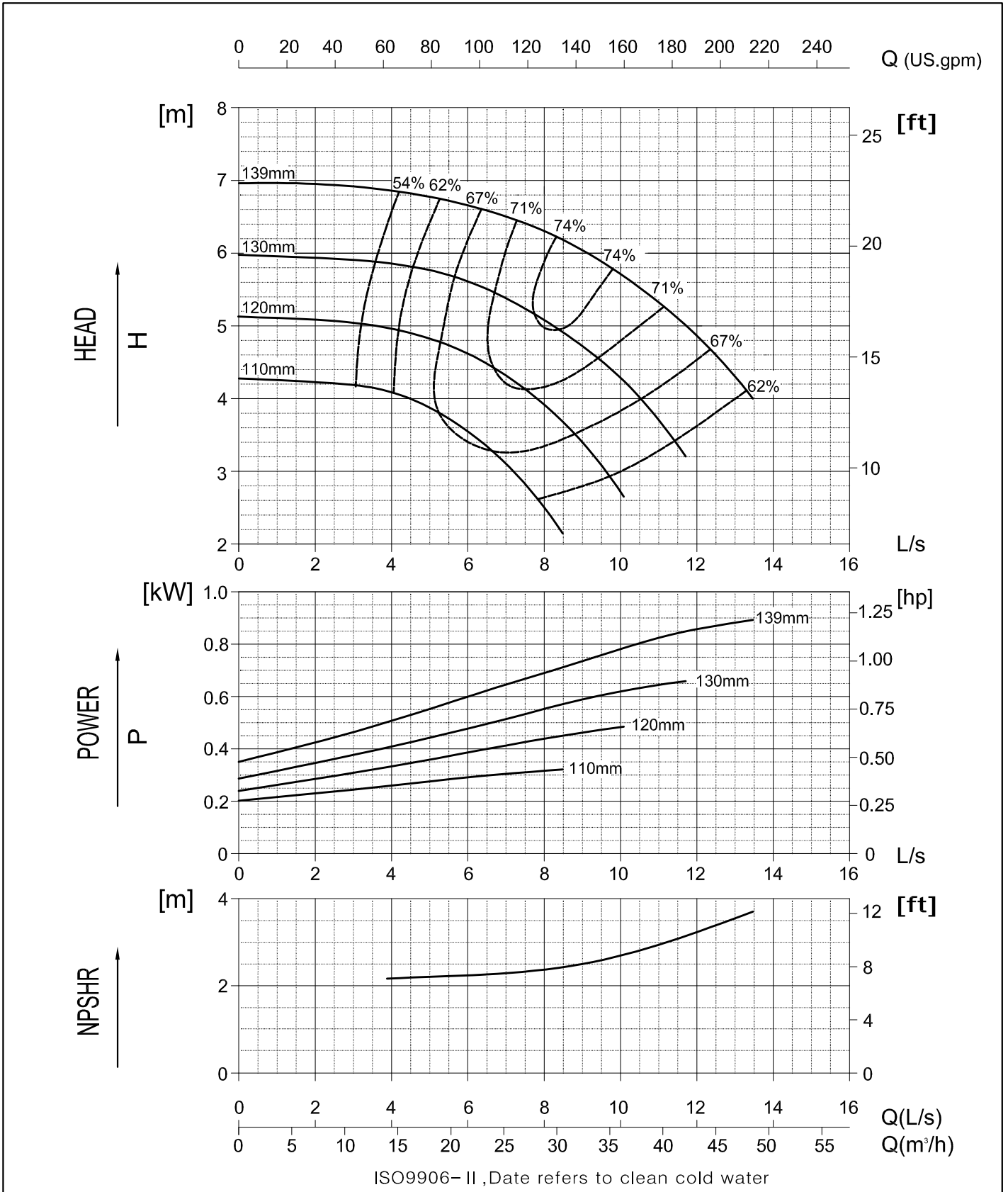

**NW50-160**  
1450 RPM

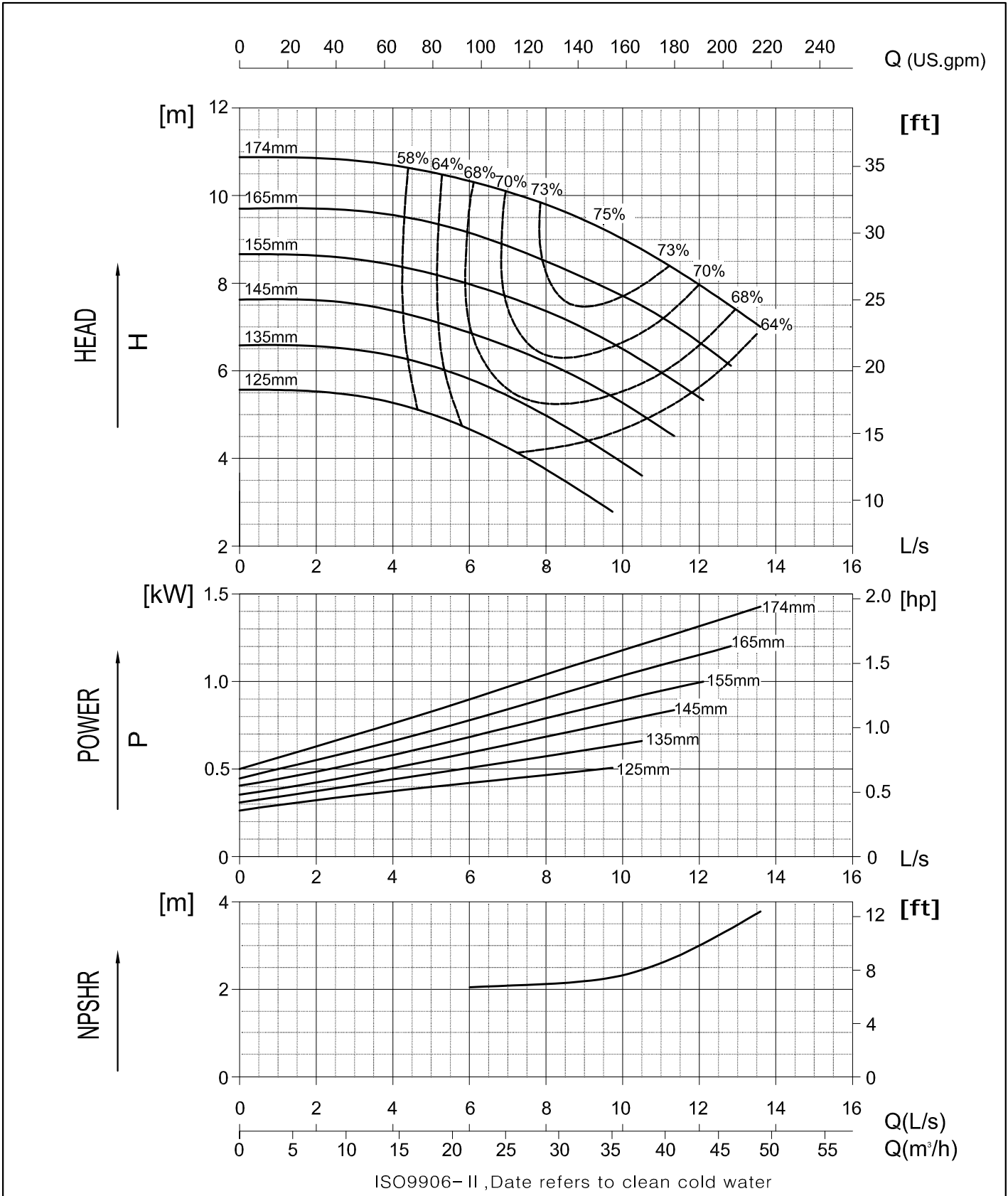

**NW50-200**  
1450 RPM

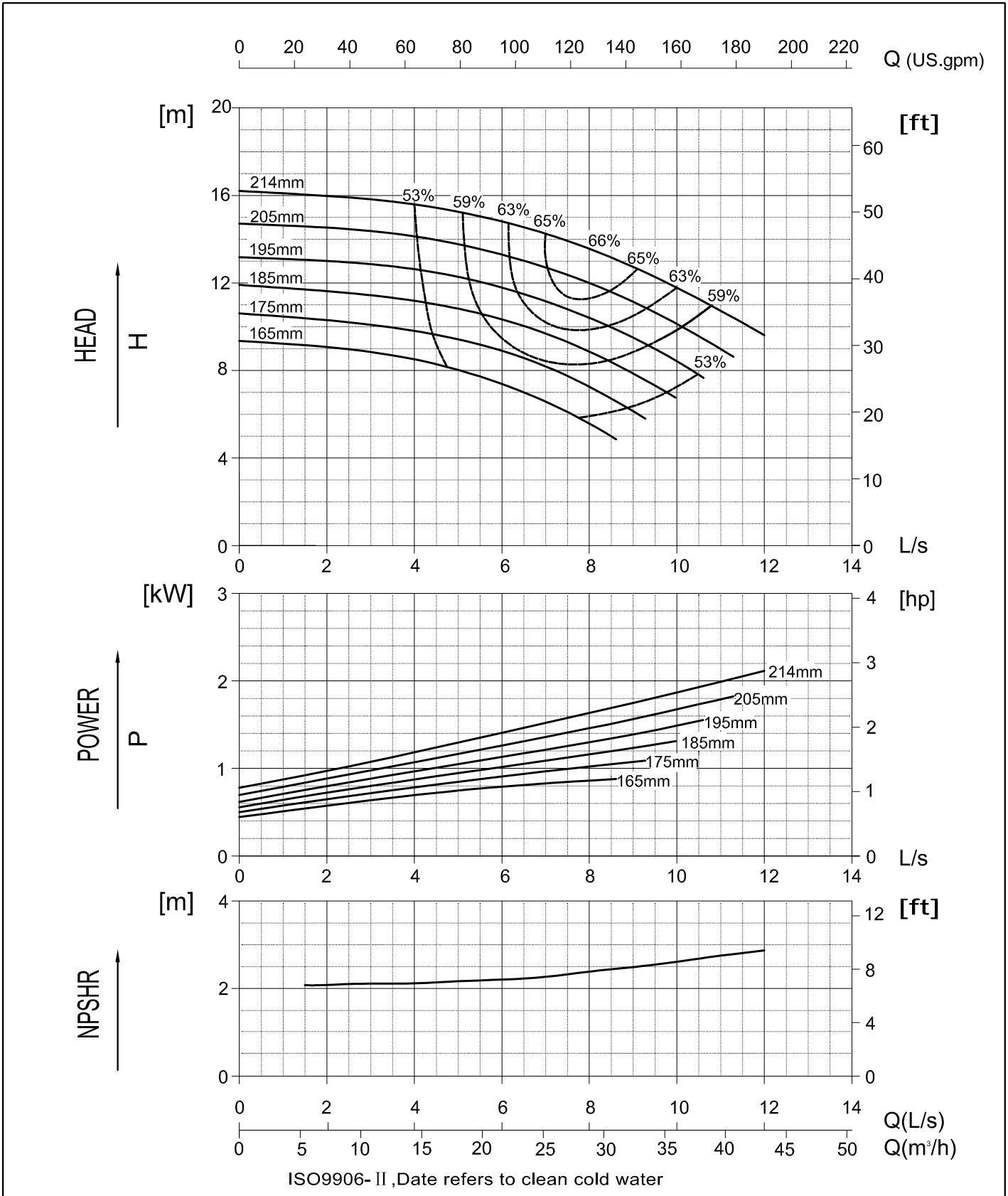

**NW50-250**  
1450 RPM

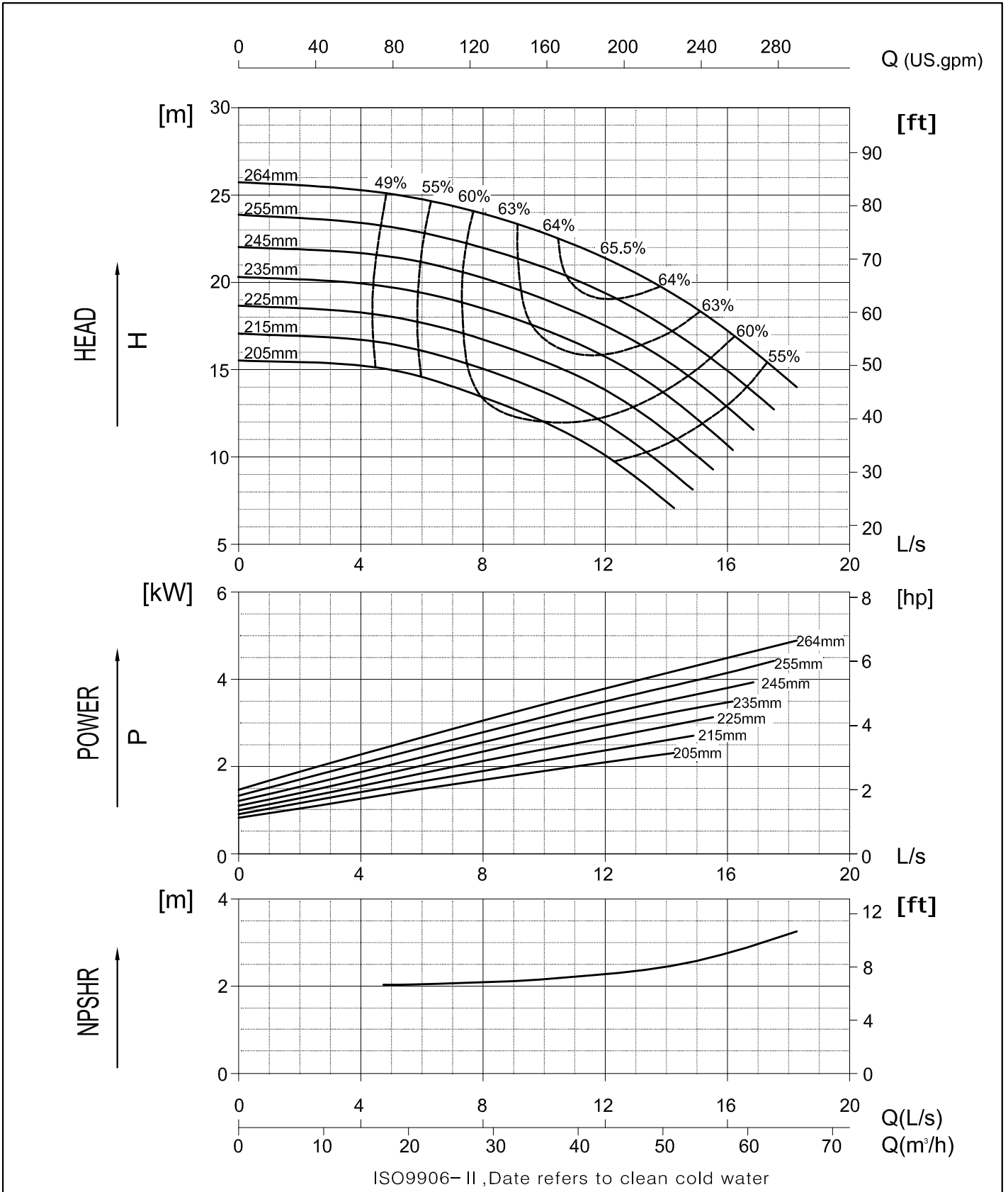

**NW50-315**  
1450 RPM

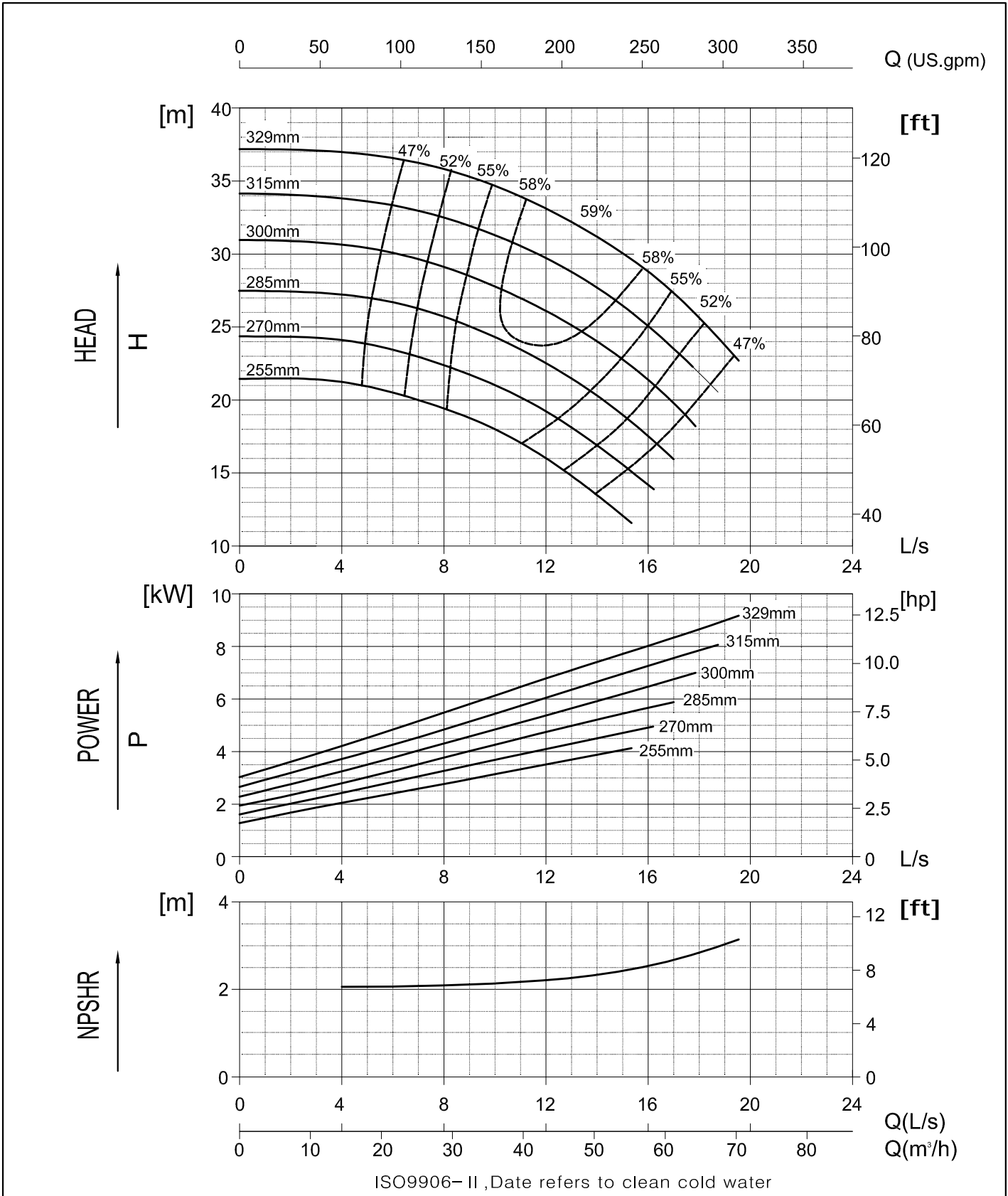

**NW65-125**  
1450 RPM

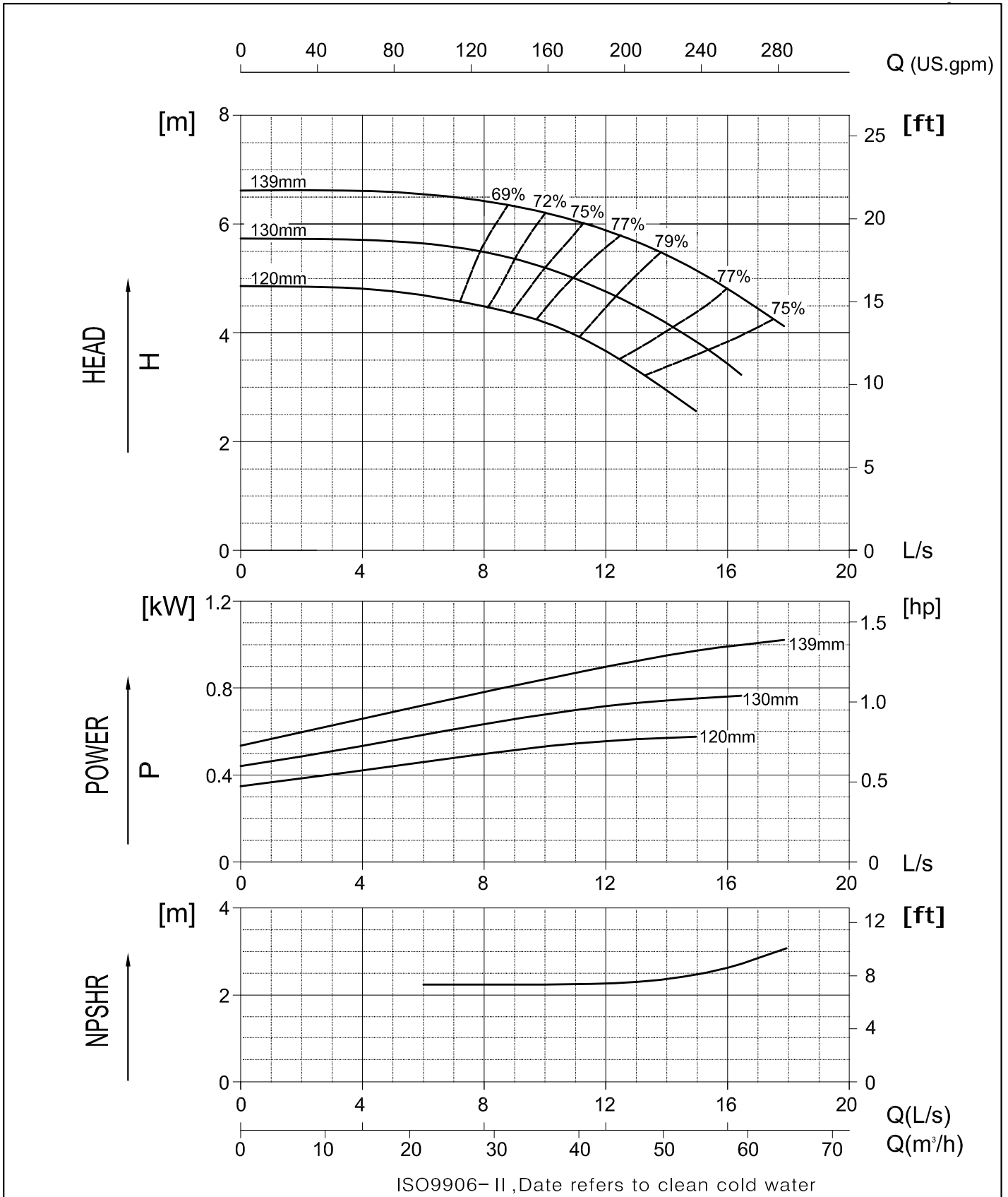

**NW65-160**  
1450 RPM

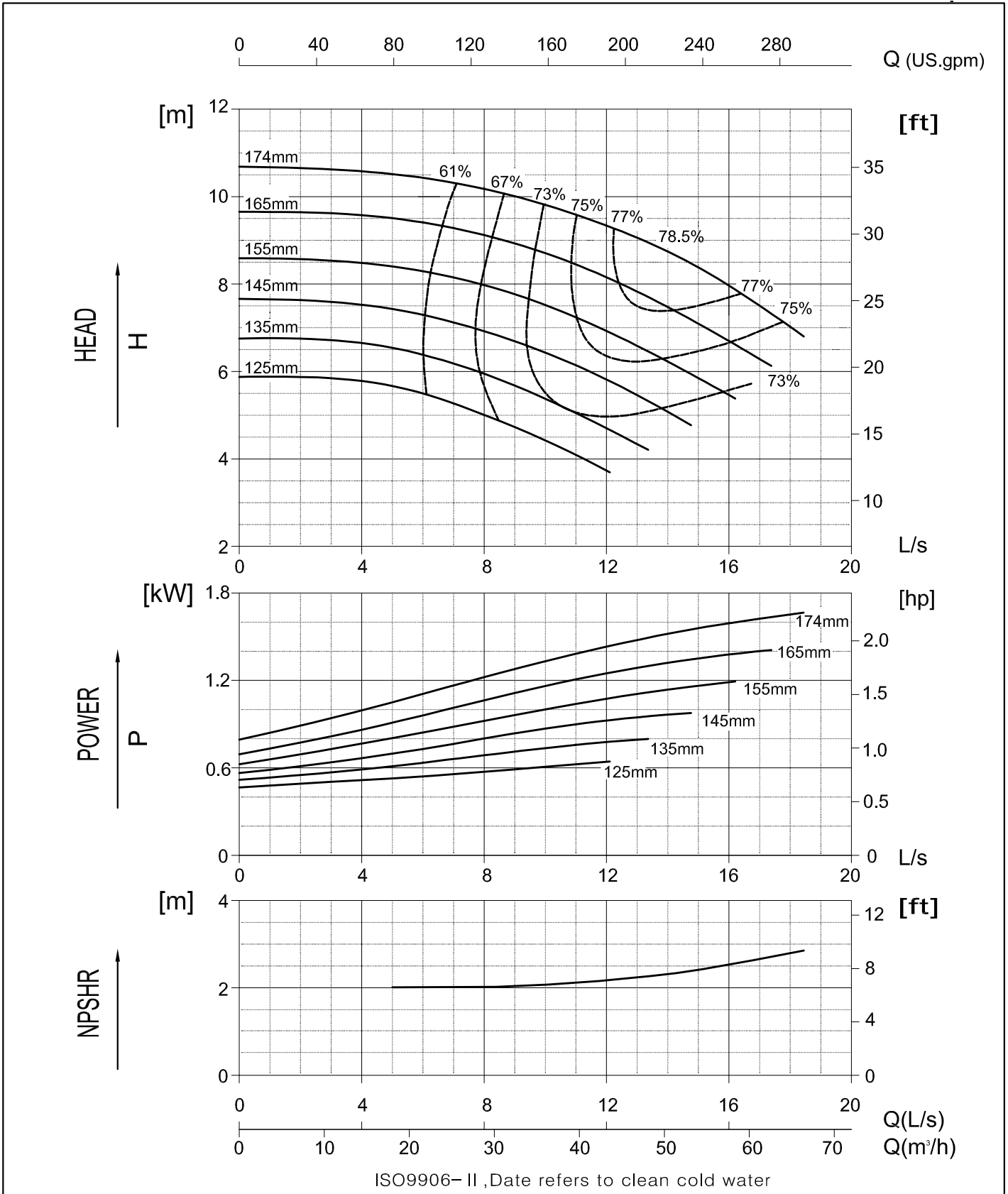

**NW65-200**  
1450 RPM

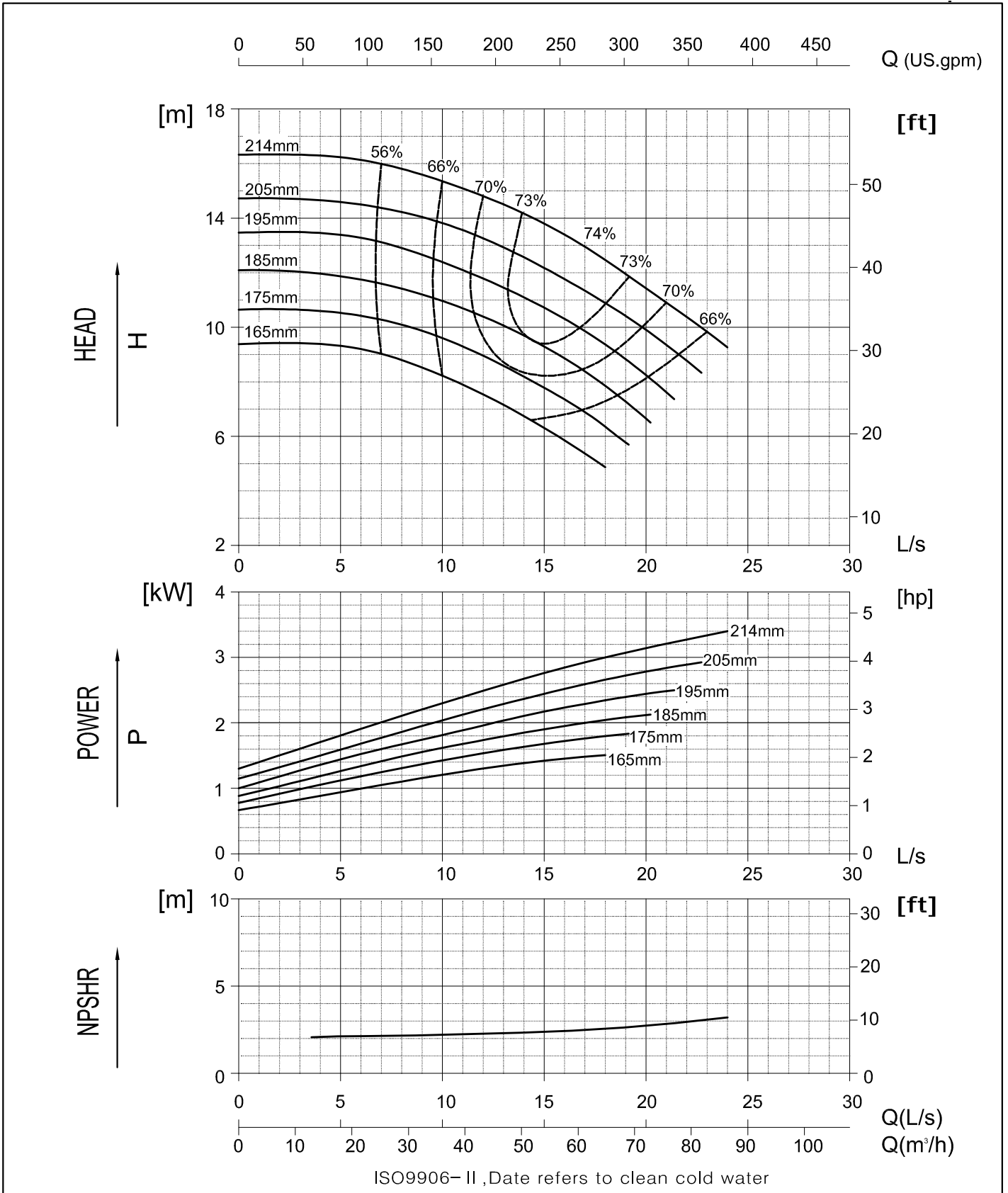

**NW65-250**  
1450 RPM

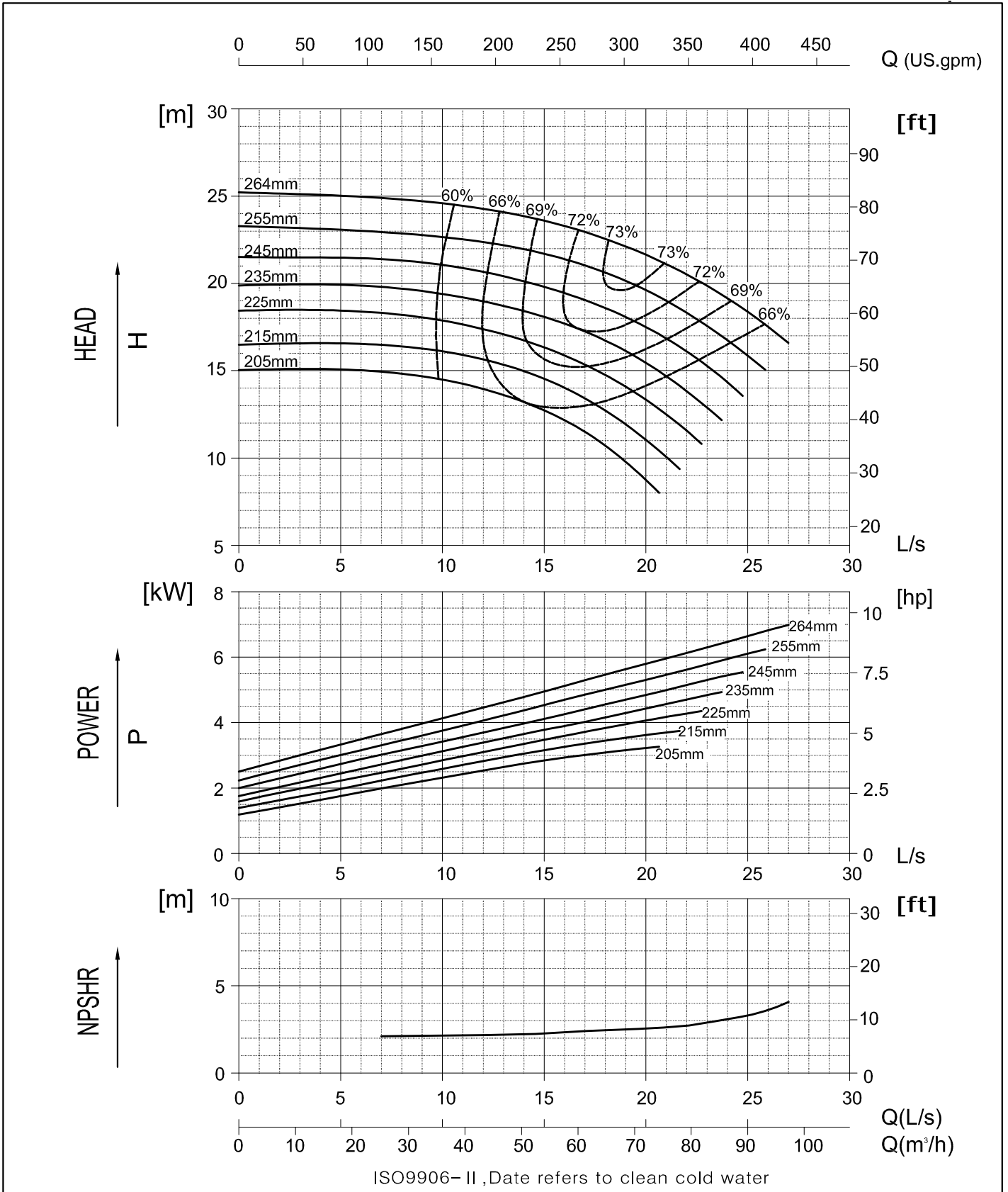

# NW65-315

1450 RPM

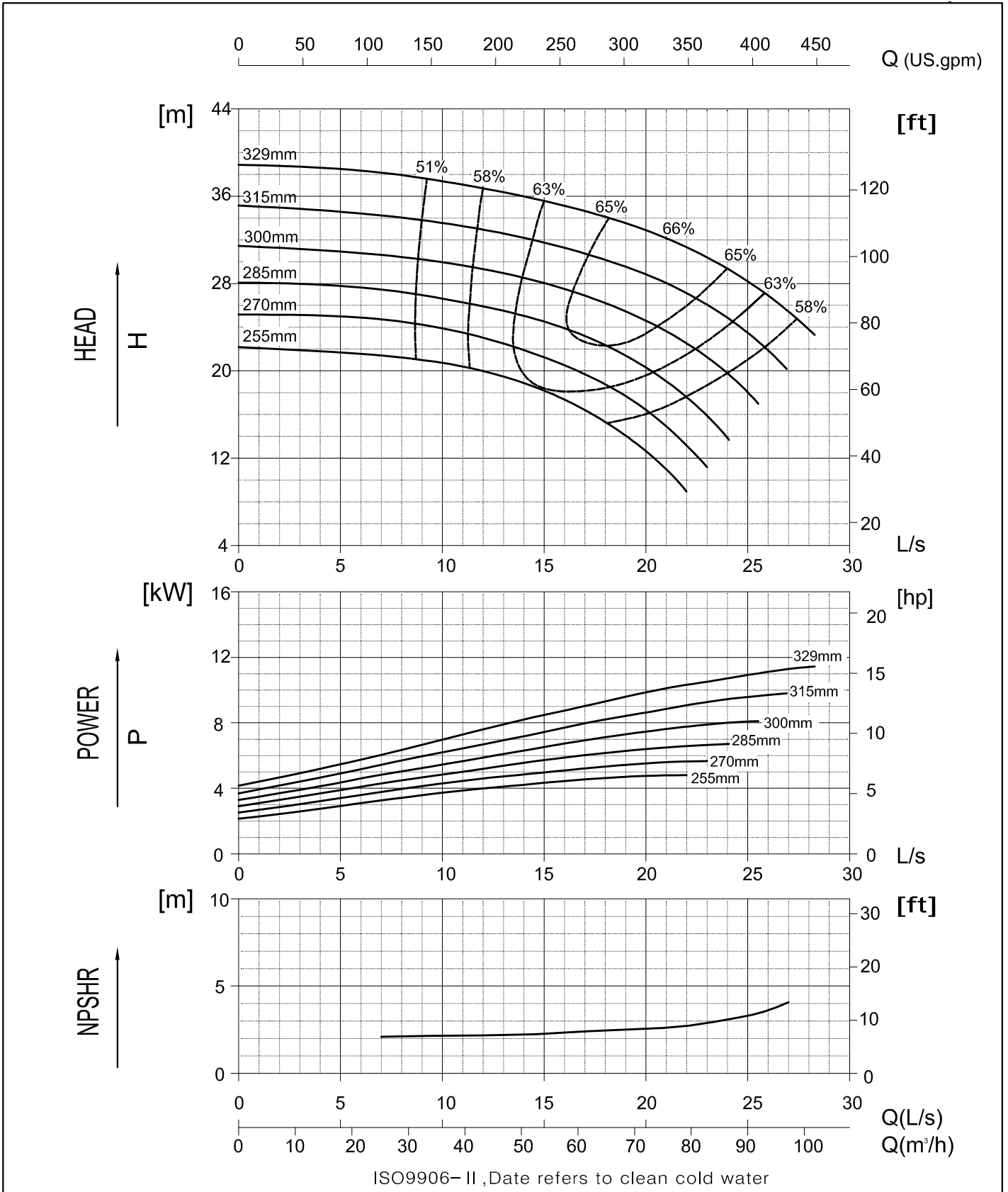

**NW80-160**  
1450 RPM

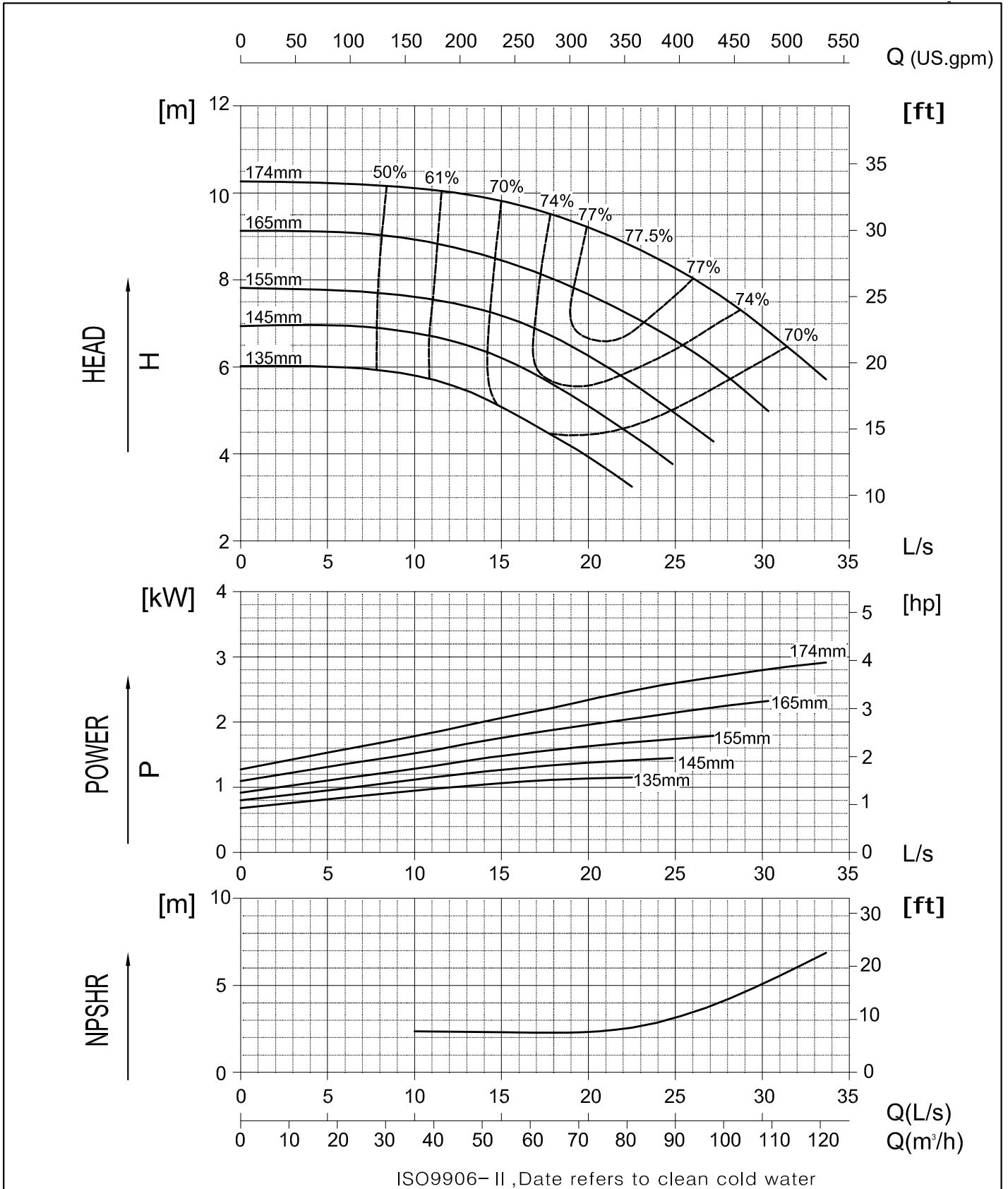

**NW80-200**  
1450 RPM

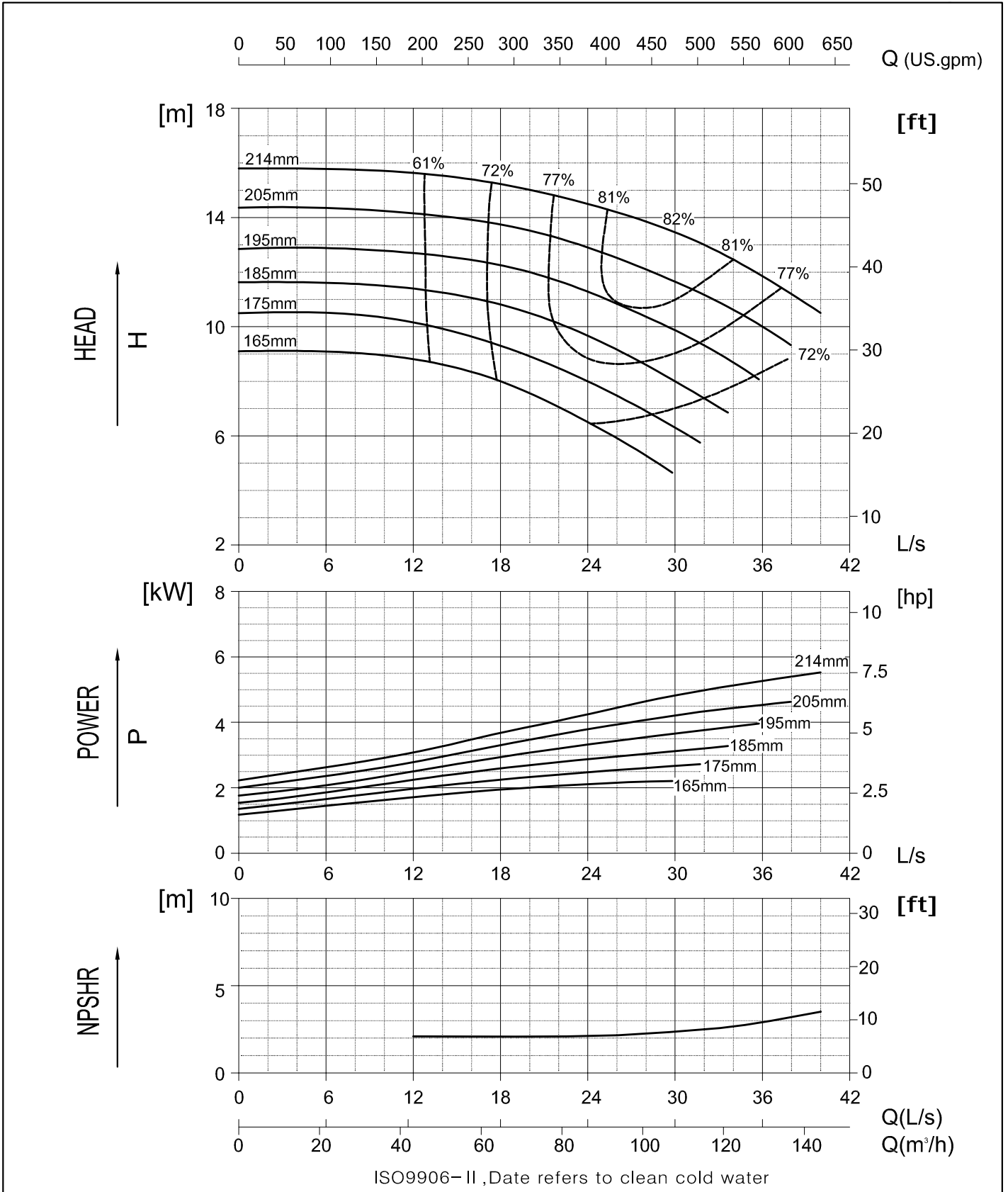

**NW80-250**  
1450 RPM

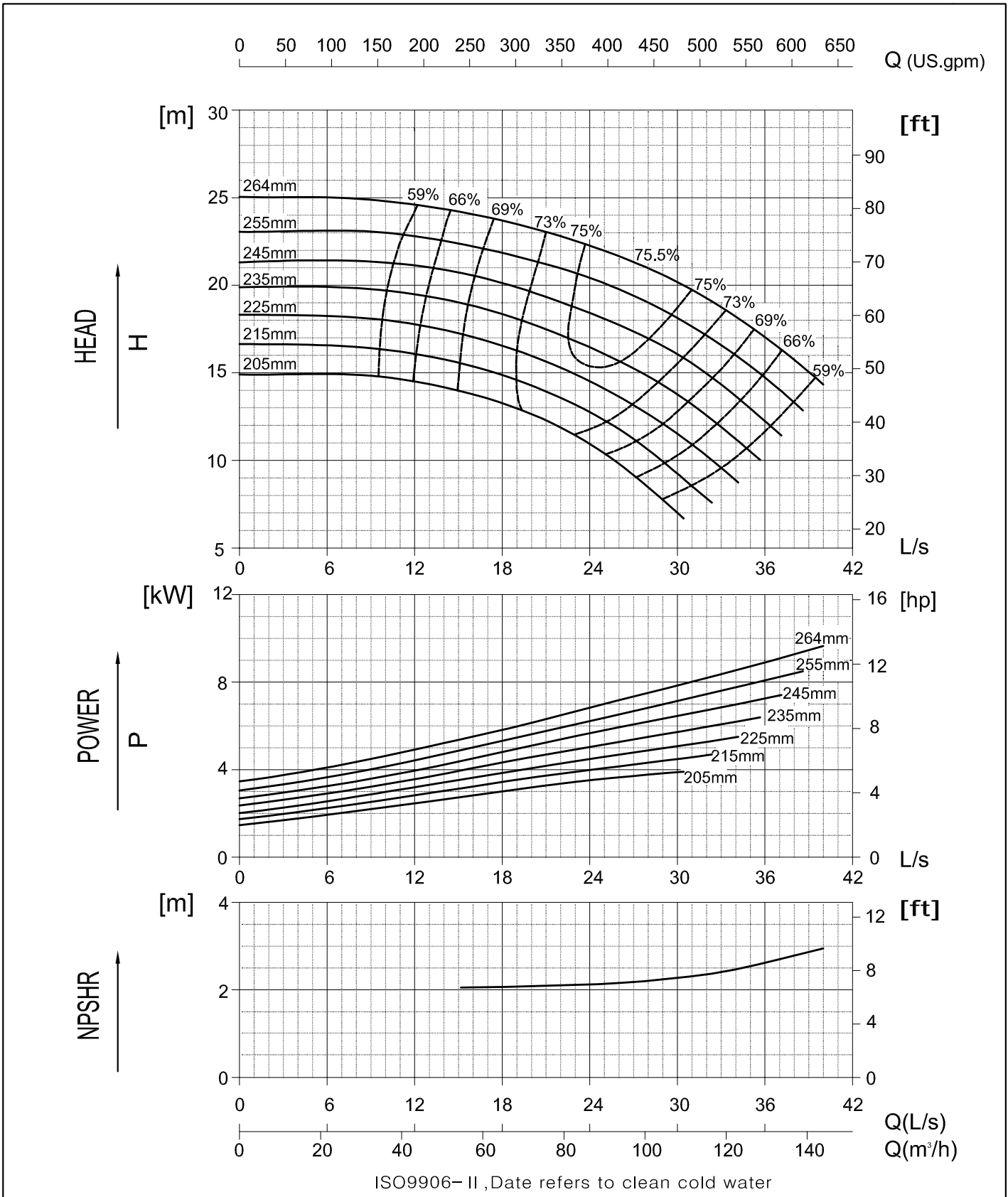

**NW80-320**  
1450 RPM

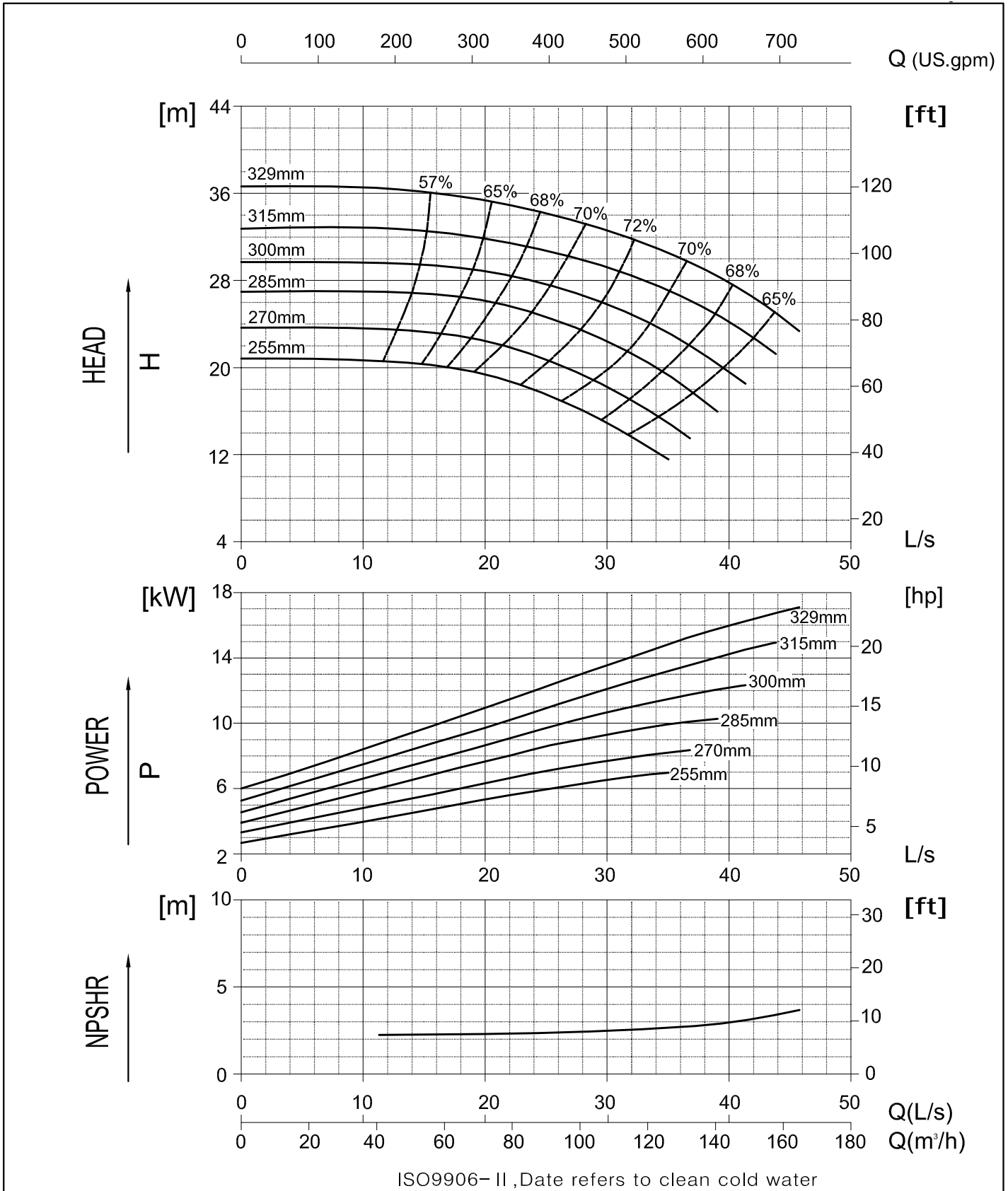

**NW80-400**  
1450 RPM

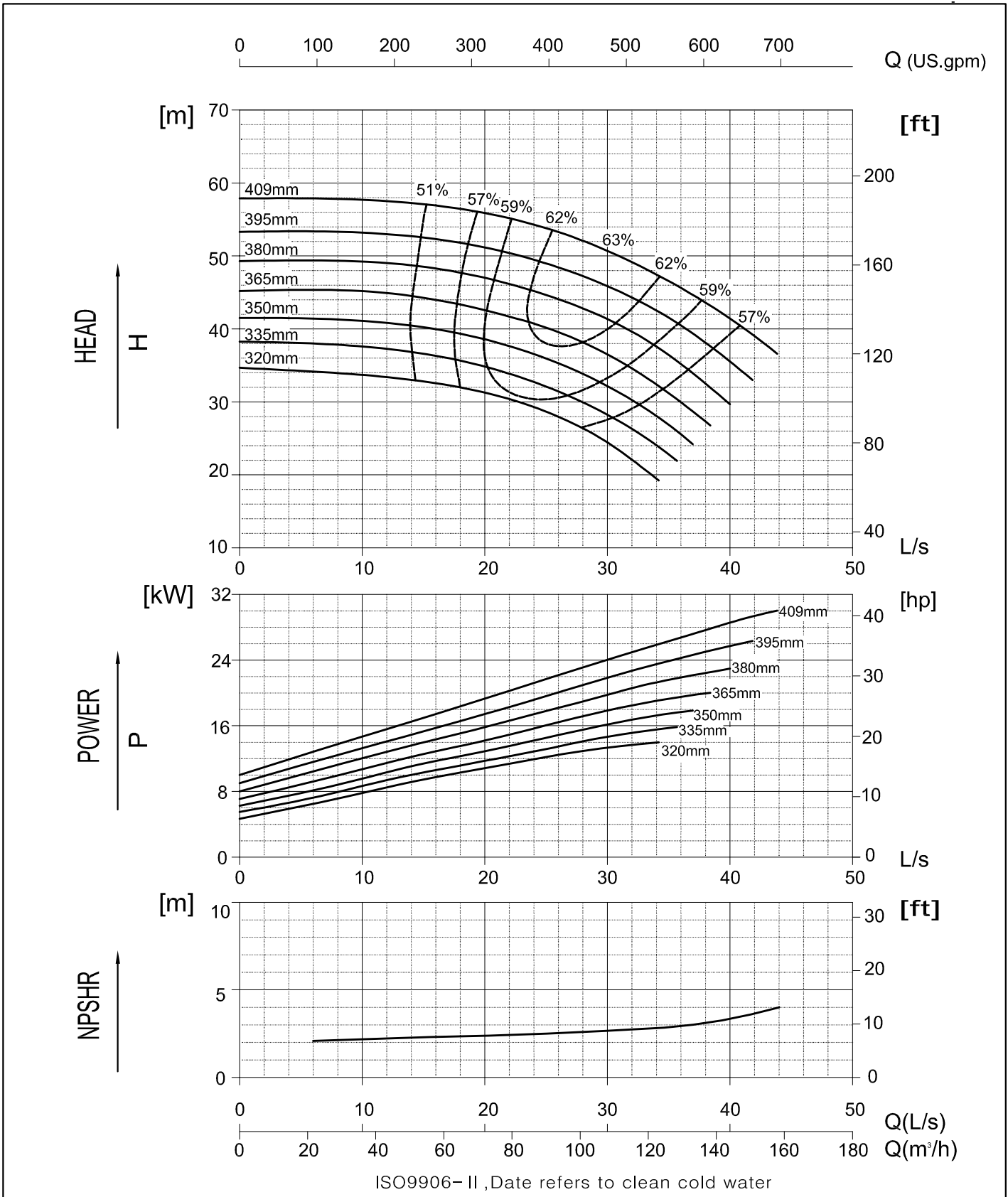

**NW100-160**  
1450 RPM

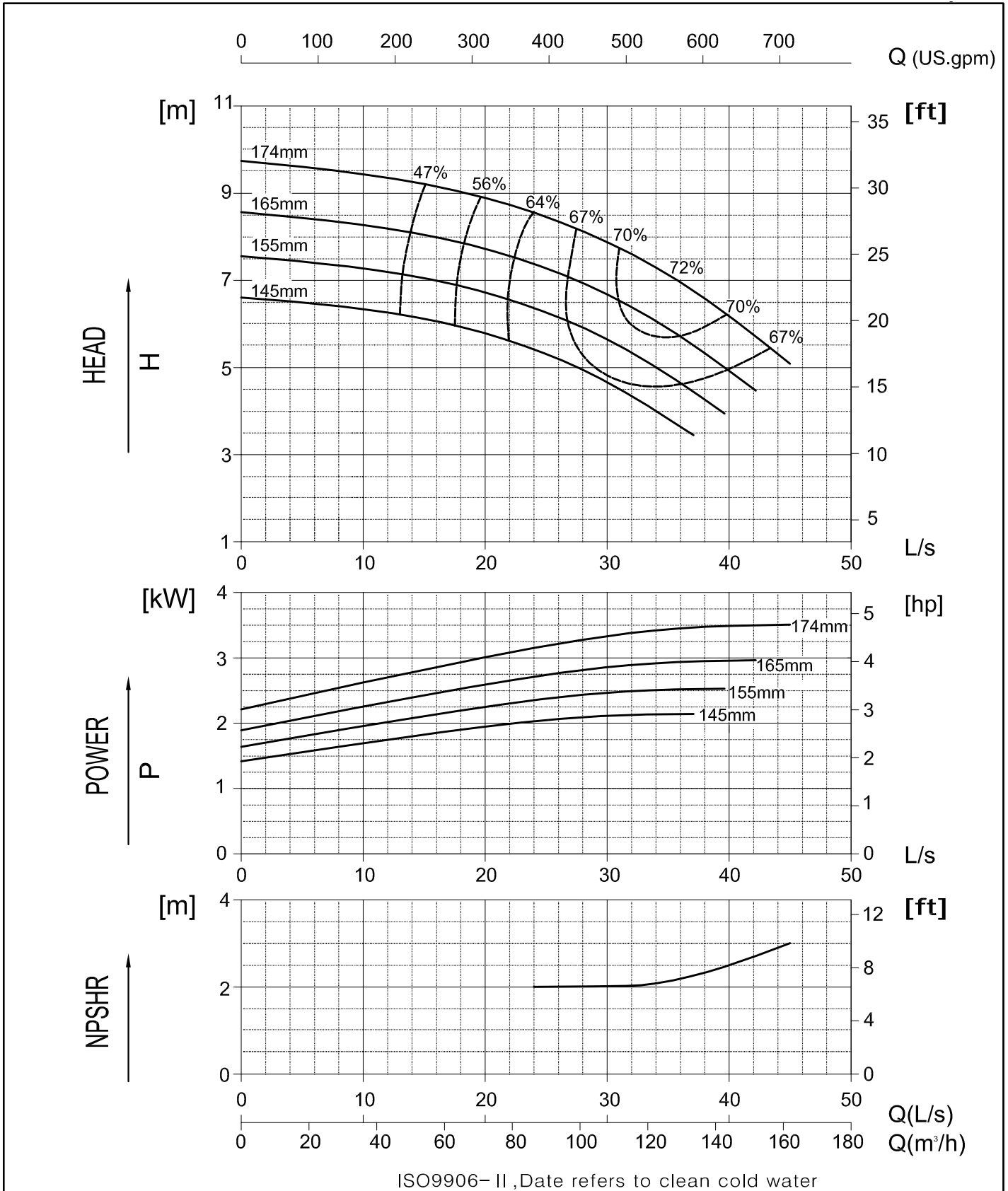

**NW100-200**  
1450 RPM

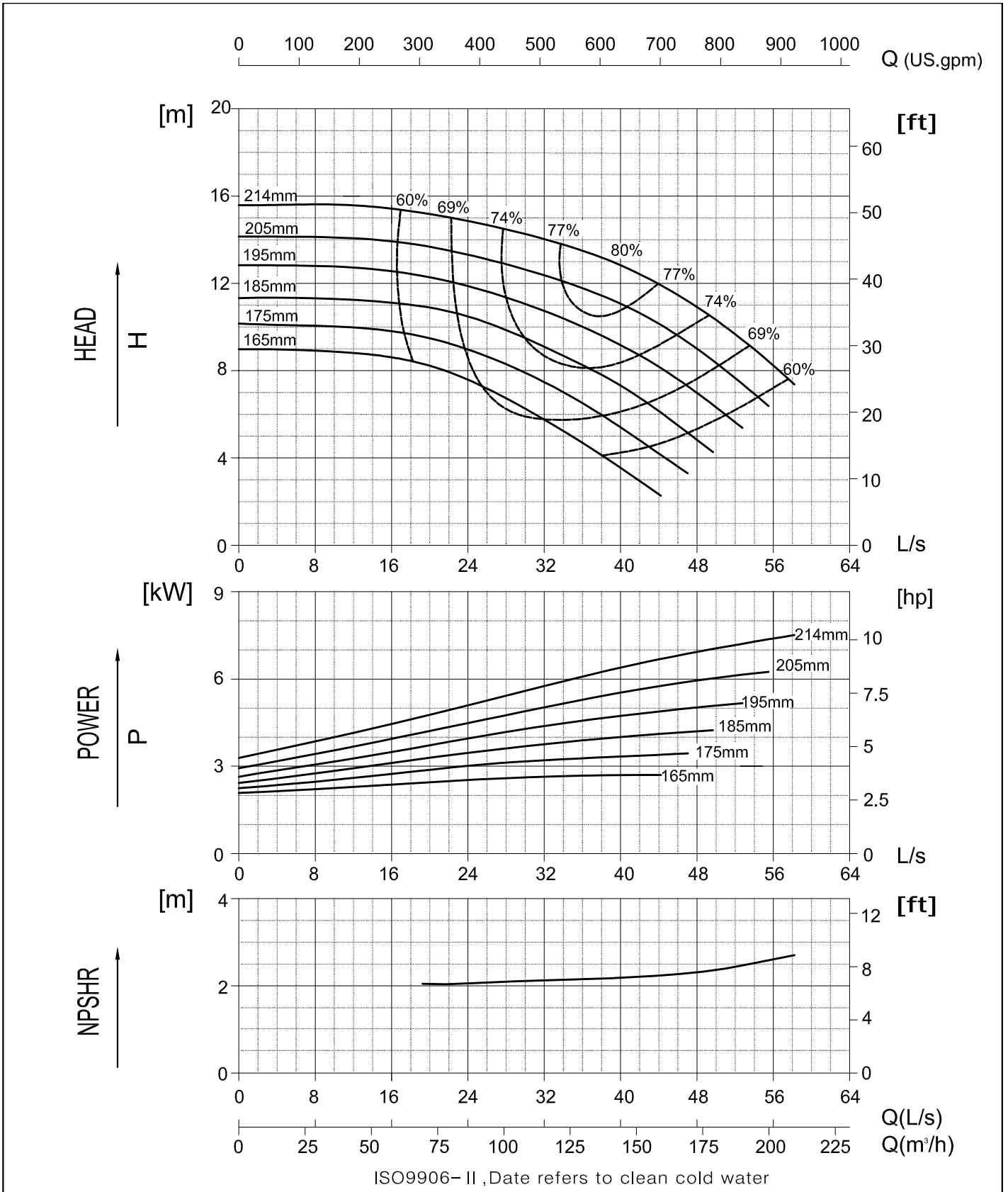

**NW100-250**  
1450 RPM

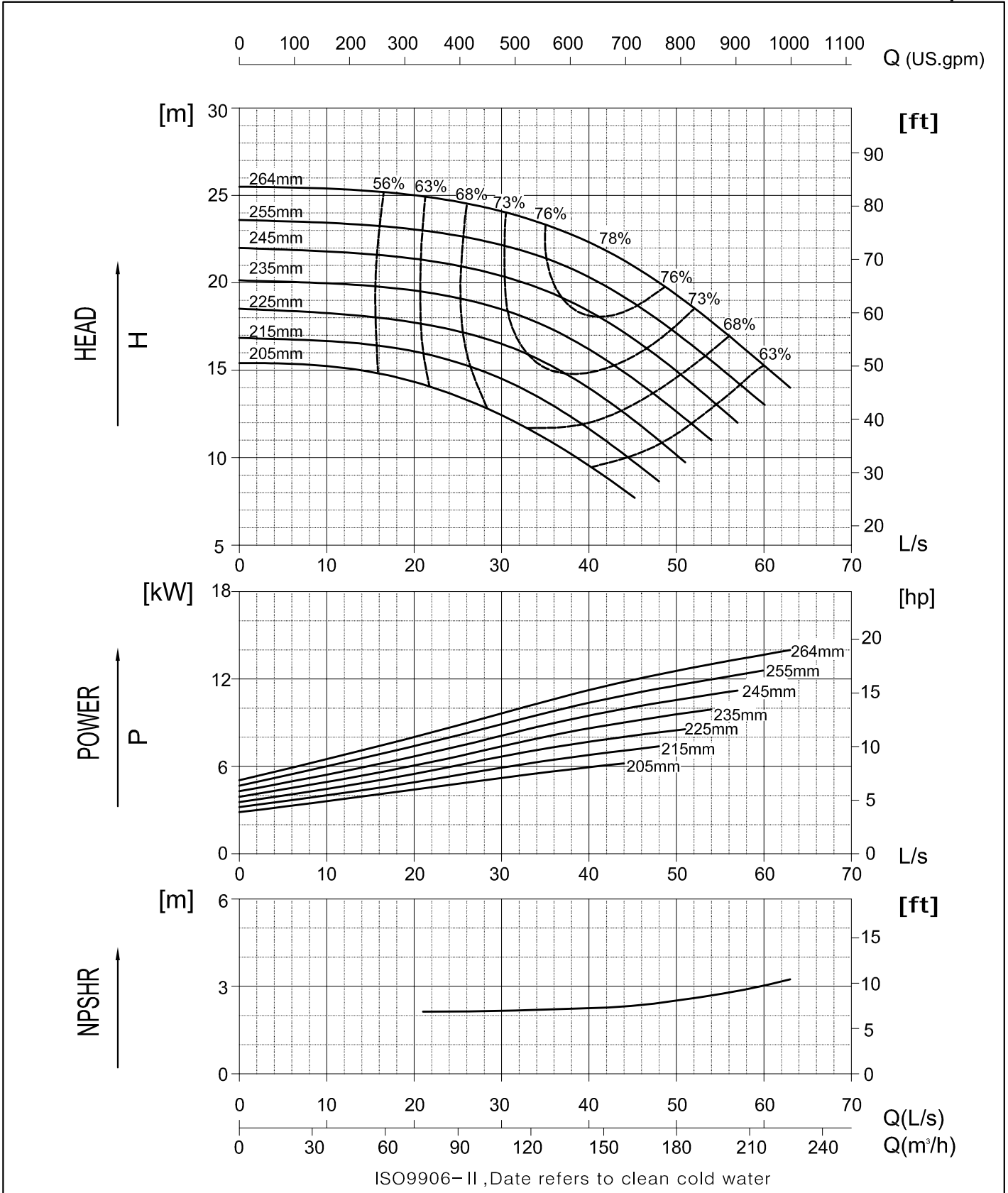

**NW100-315**  
1450 RPM

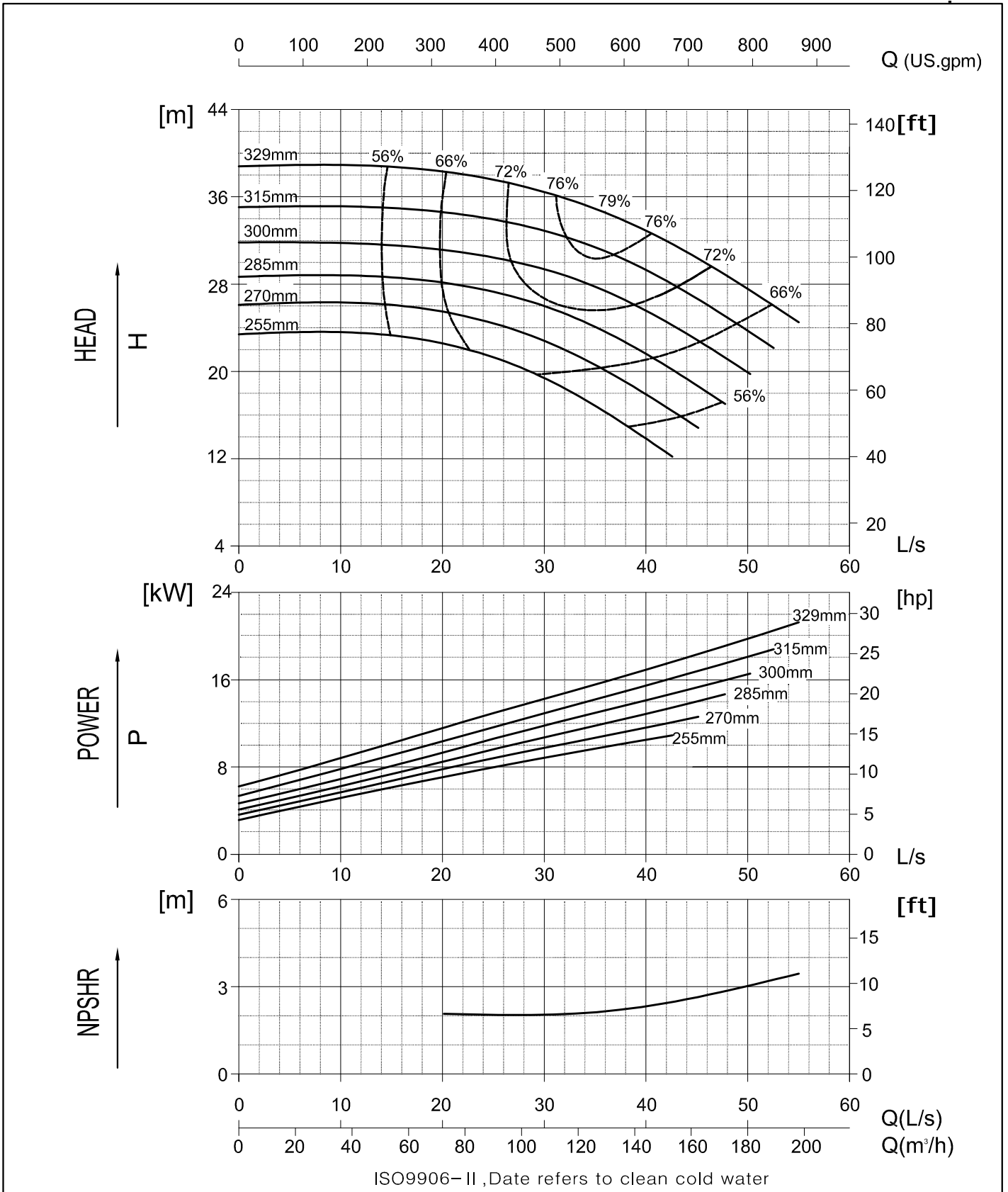

**NW100-400**  
1450 RPM

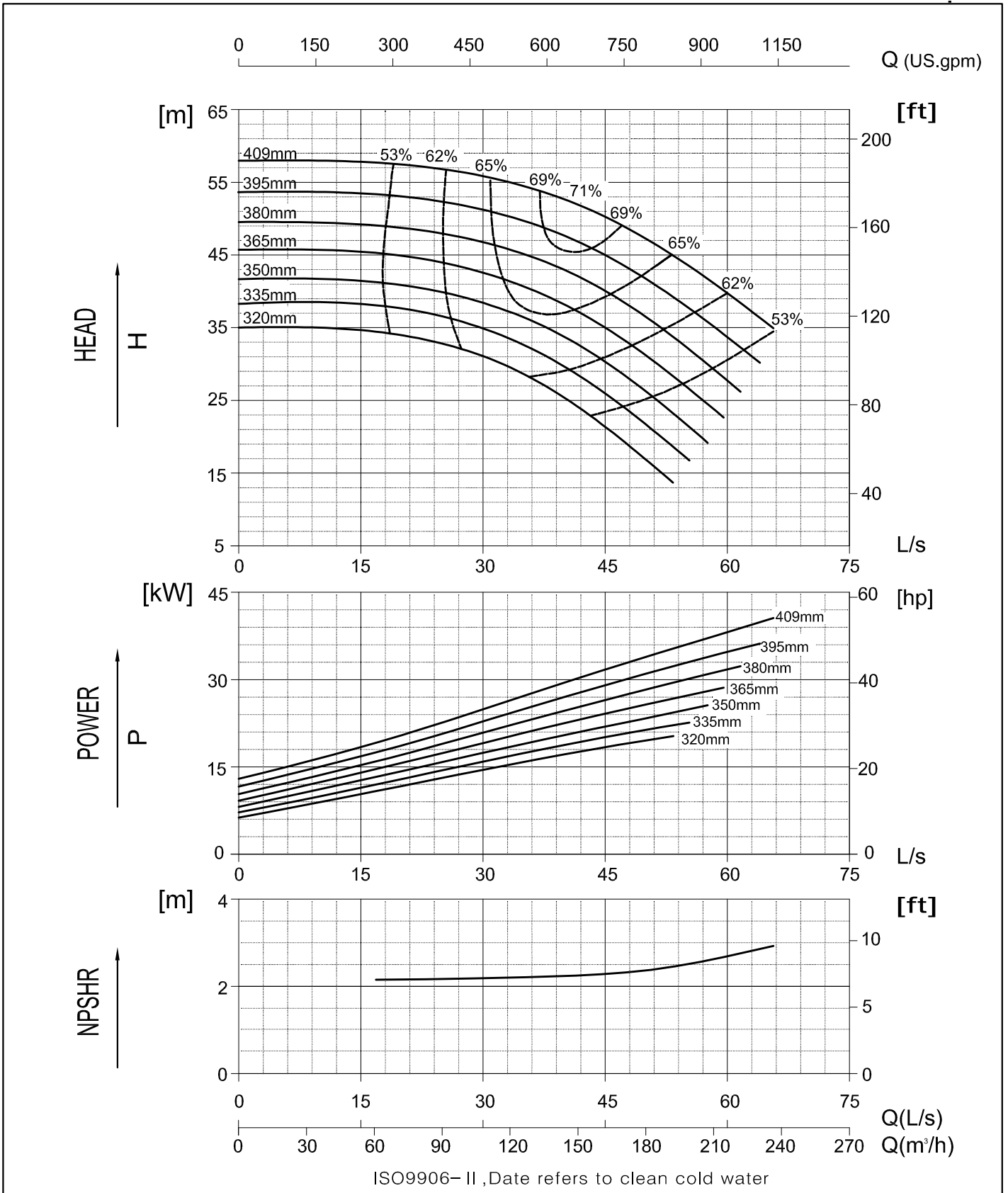

**NW125-200**  
1450 RPM

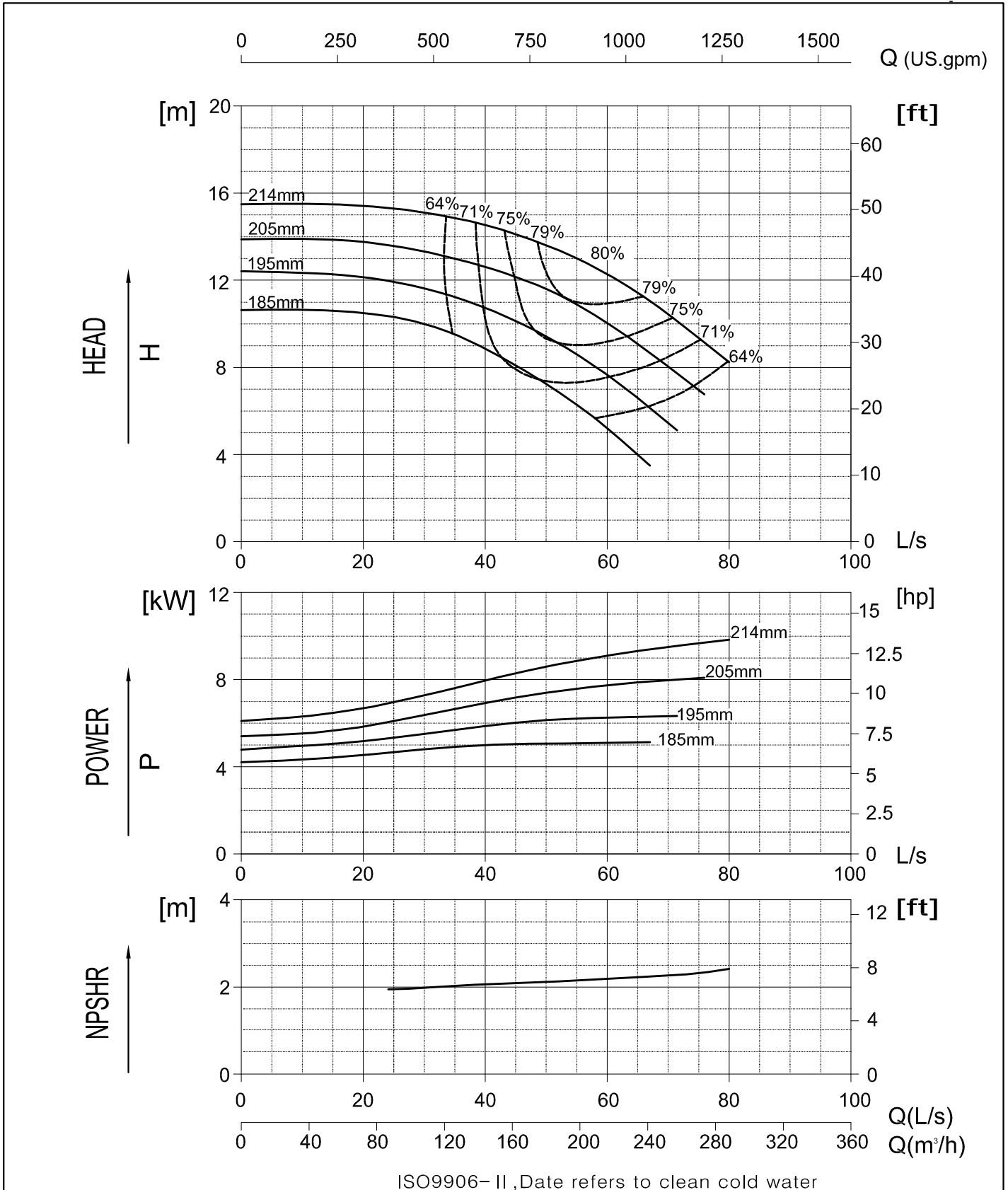

**NW125-250**  
1450 RPM

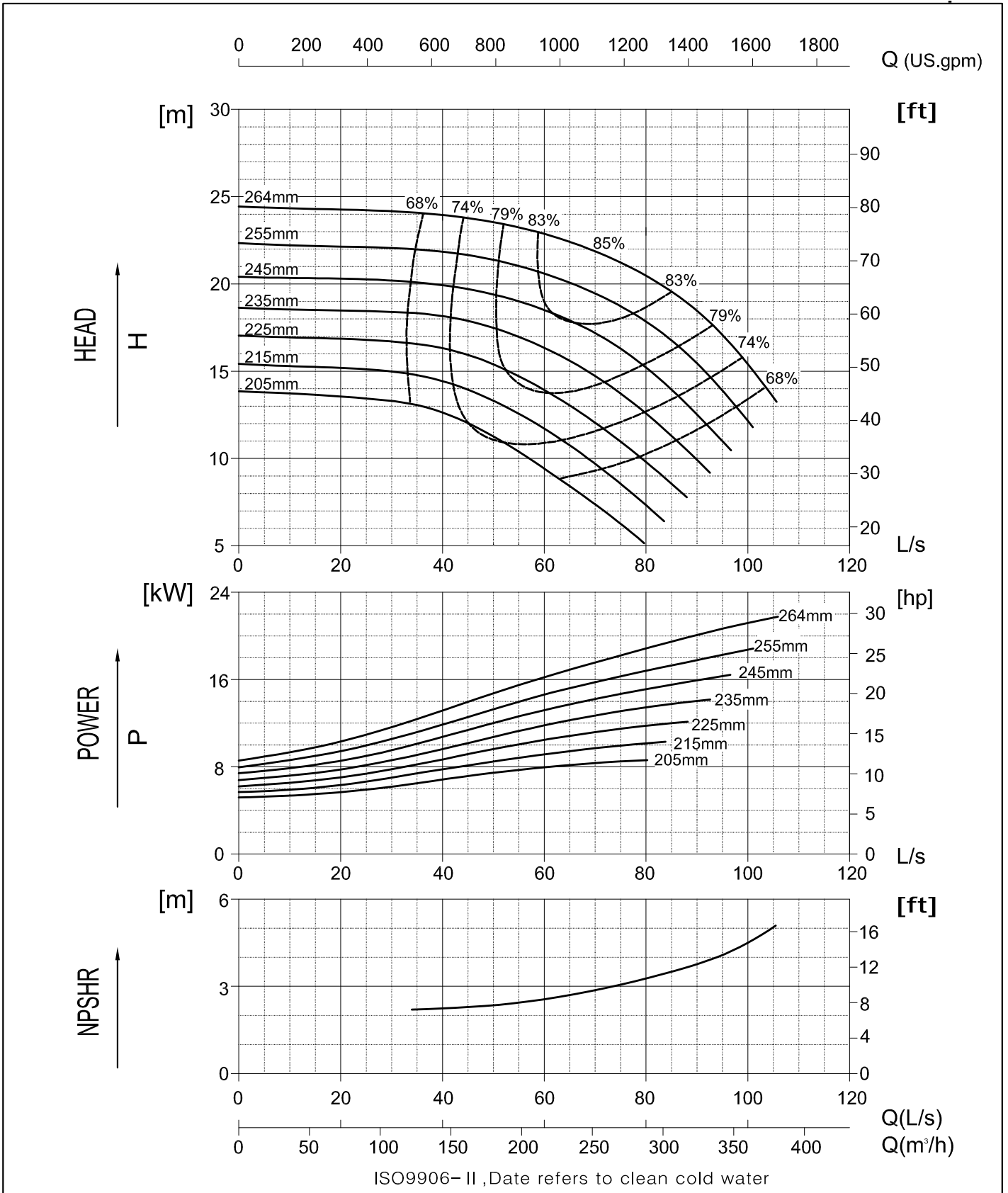

# NW125-315

1450 RPM

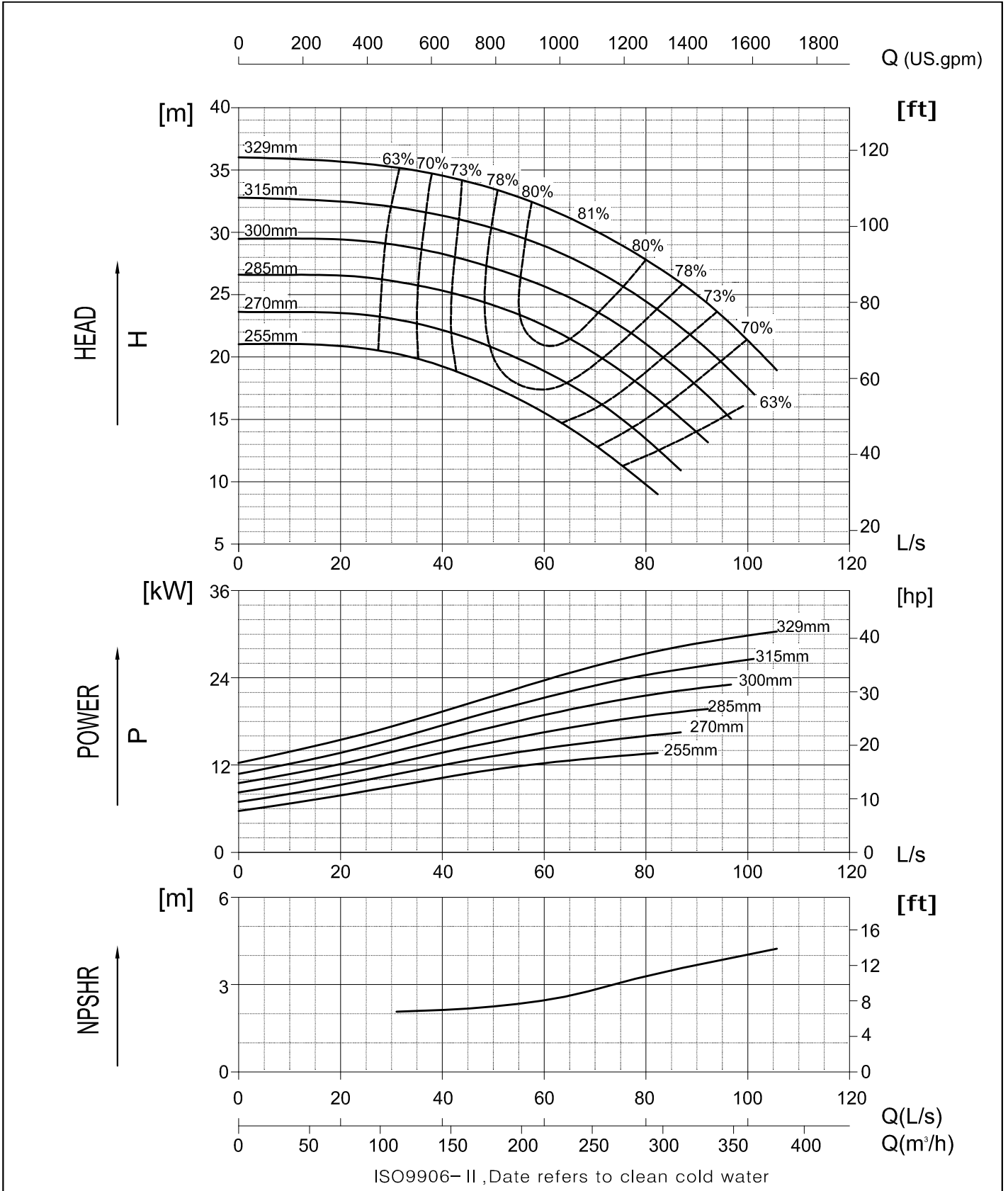

# NW125-400

1450 RPM

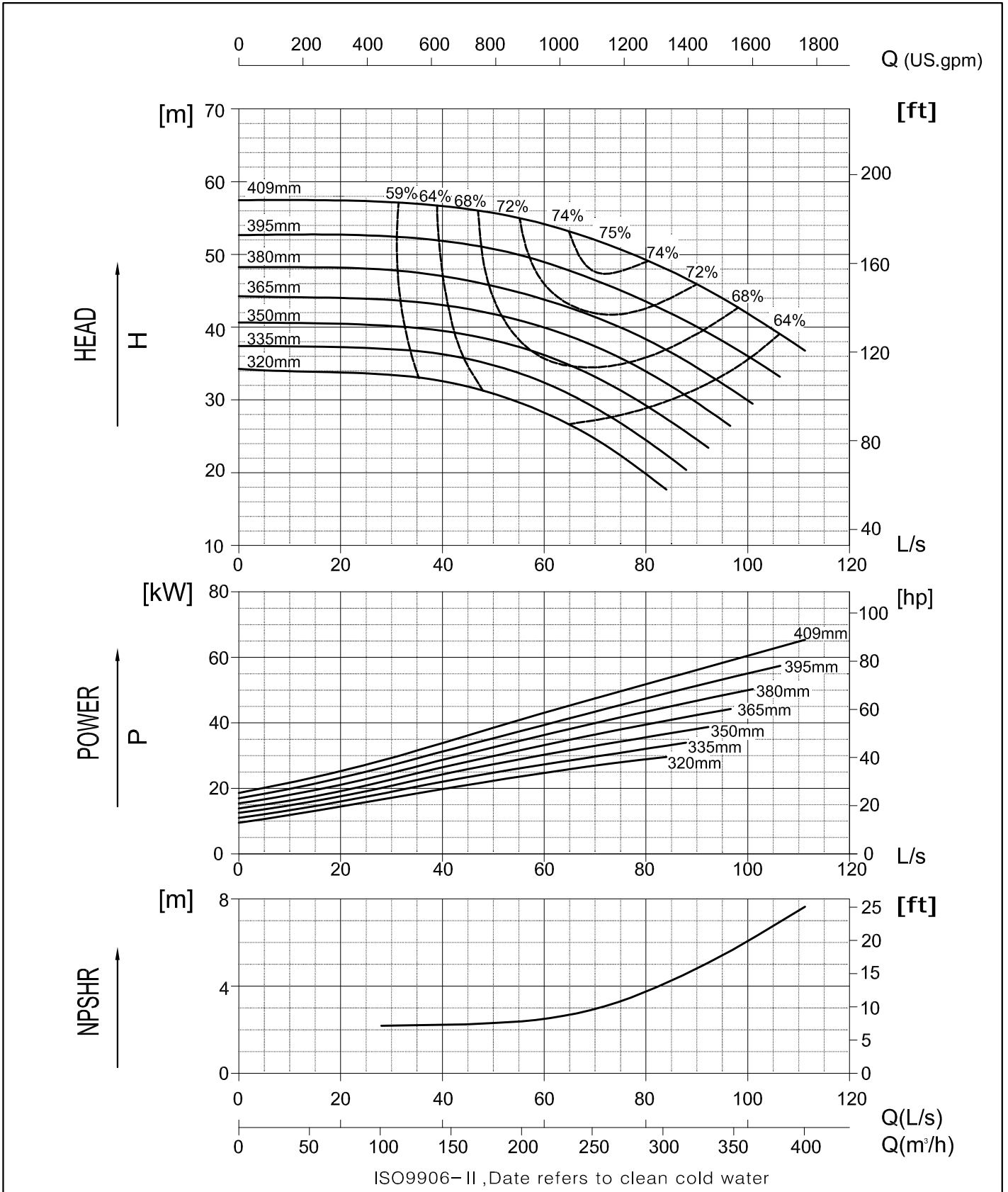

**NW150-200**  
1450 RPM

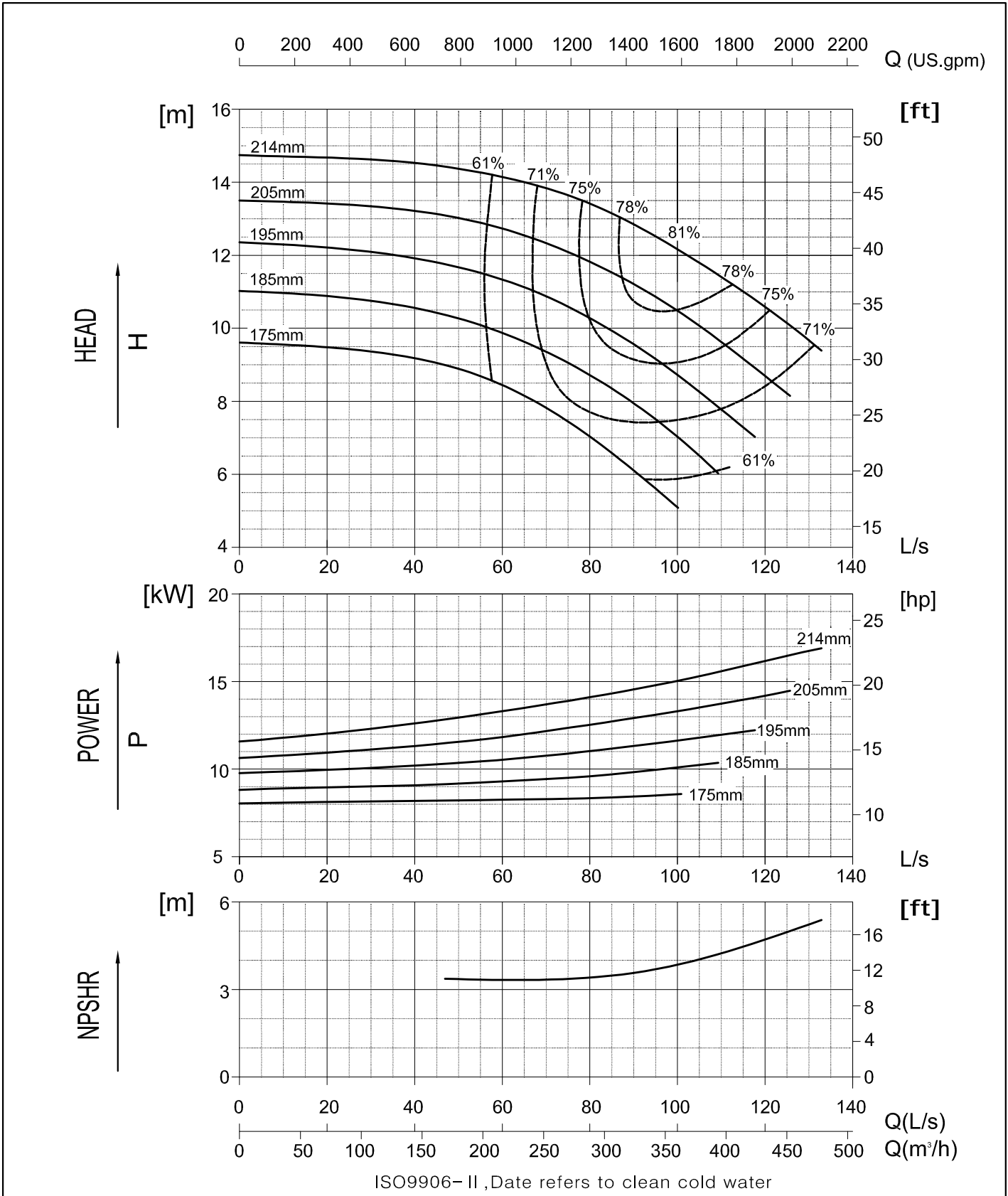

# NW150-250

1450 RPM

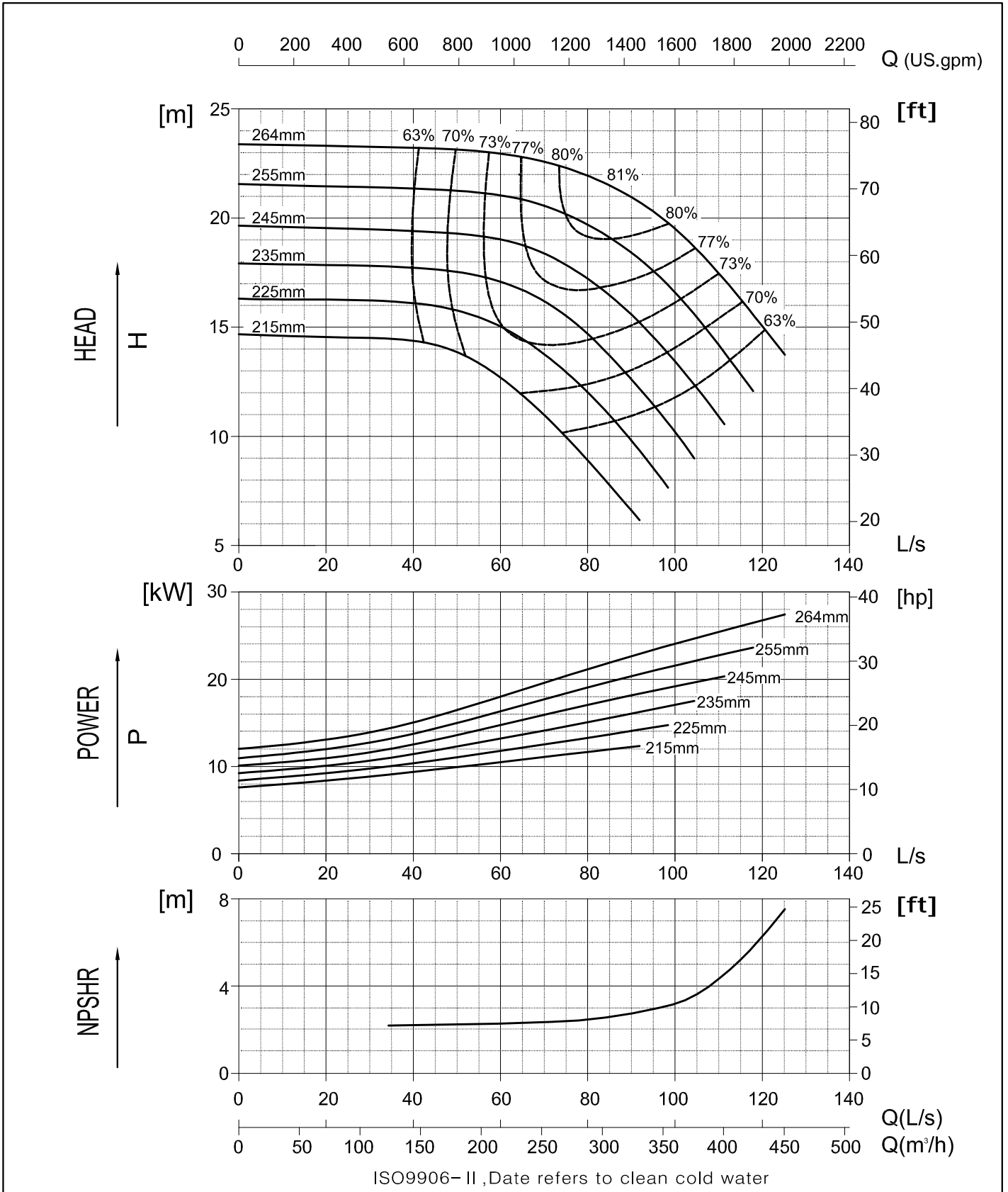

# NW150-315

1450 RPM

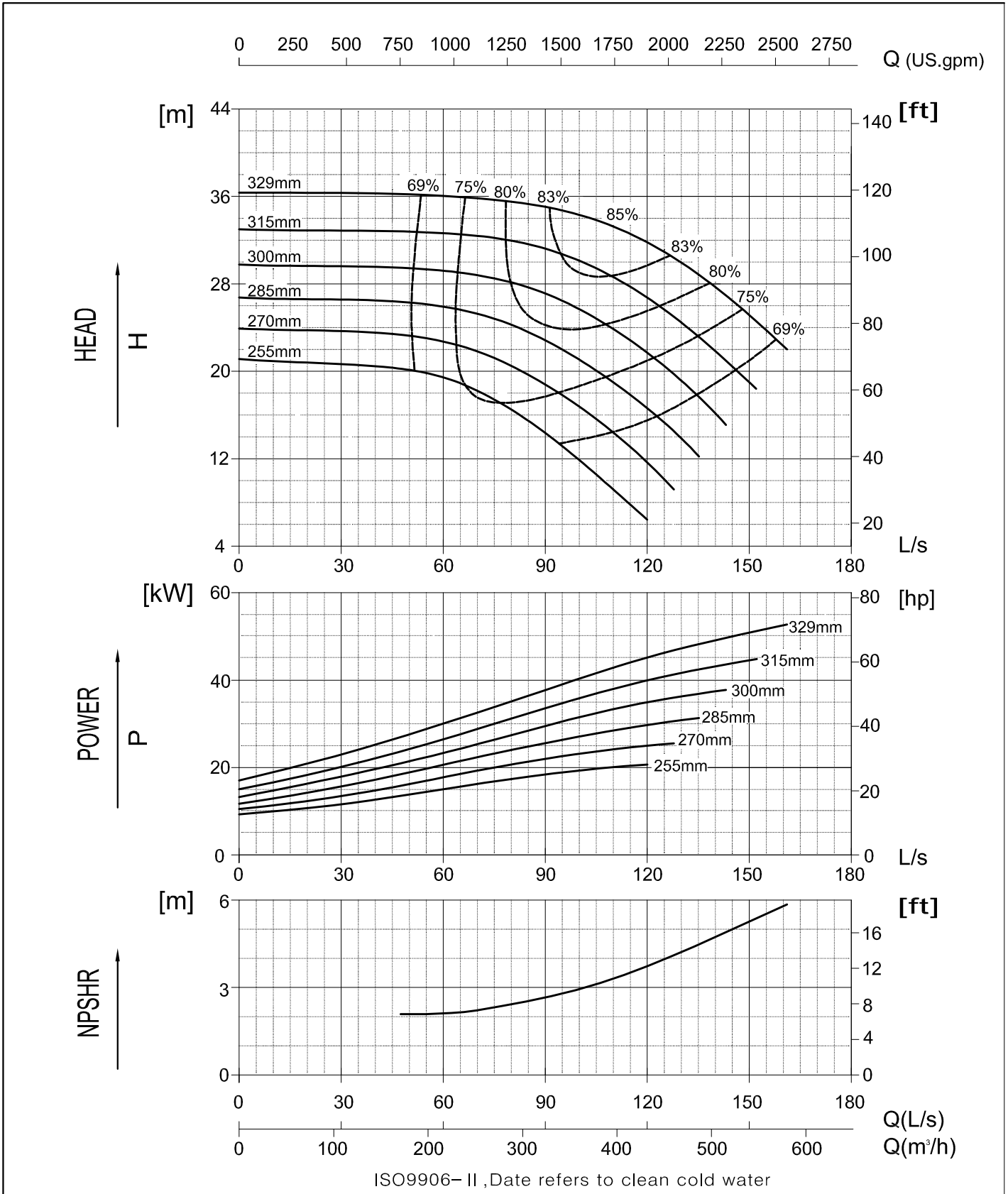

# NW150-400

1450 RPM

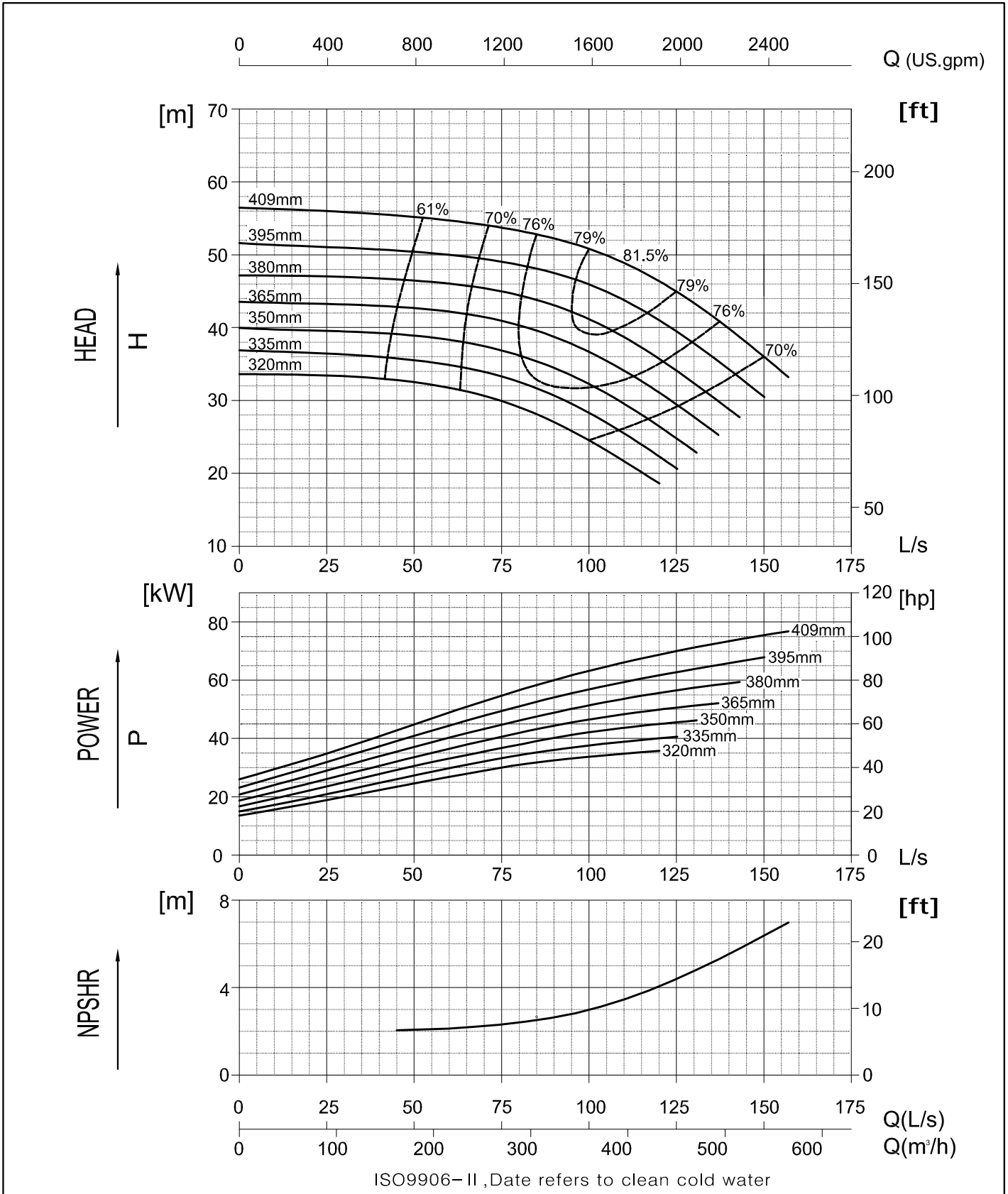

**NW200-260**  
1450 RPM

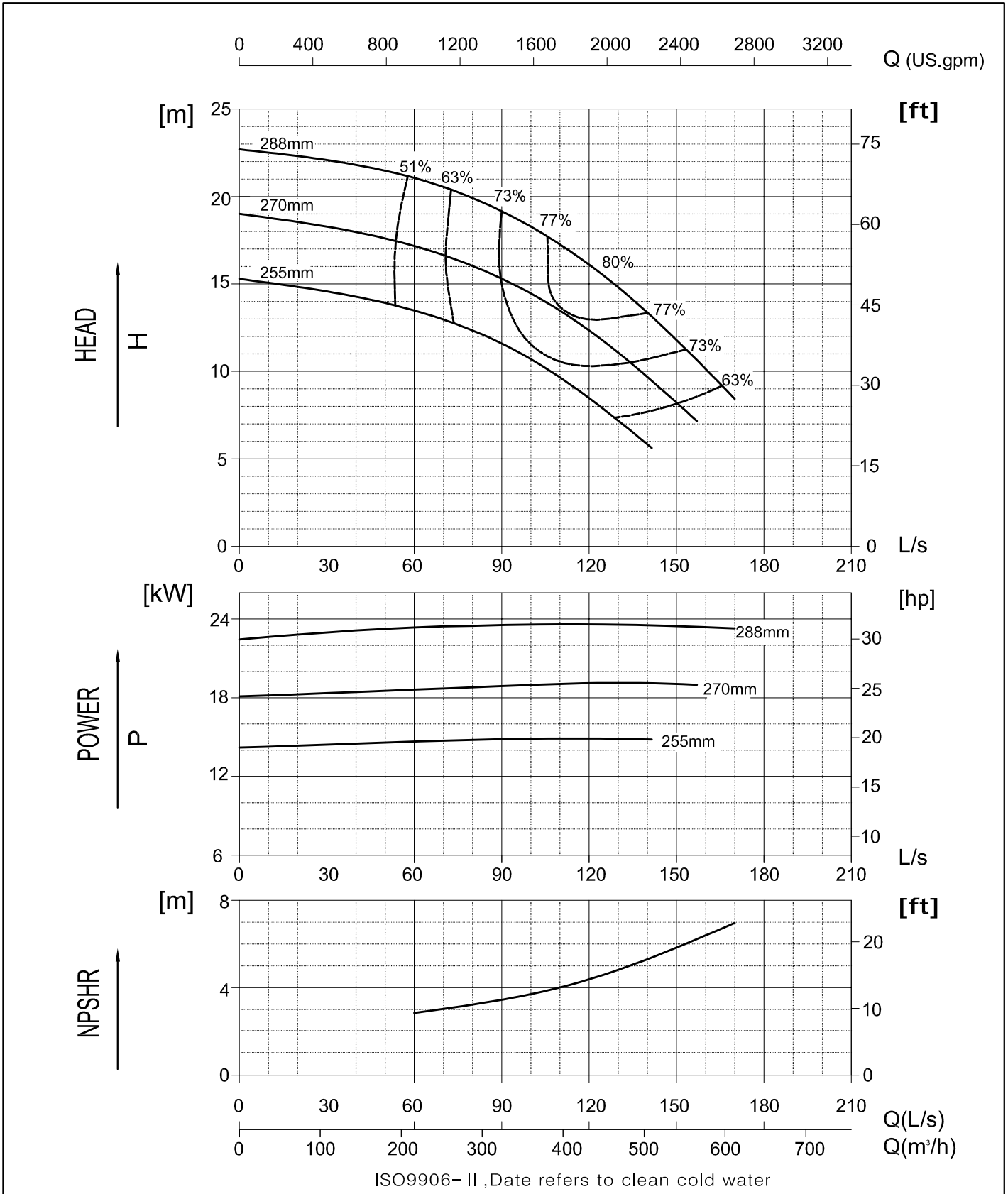

**NW200-320**  
1450 RPM

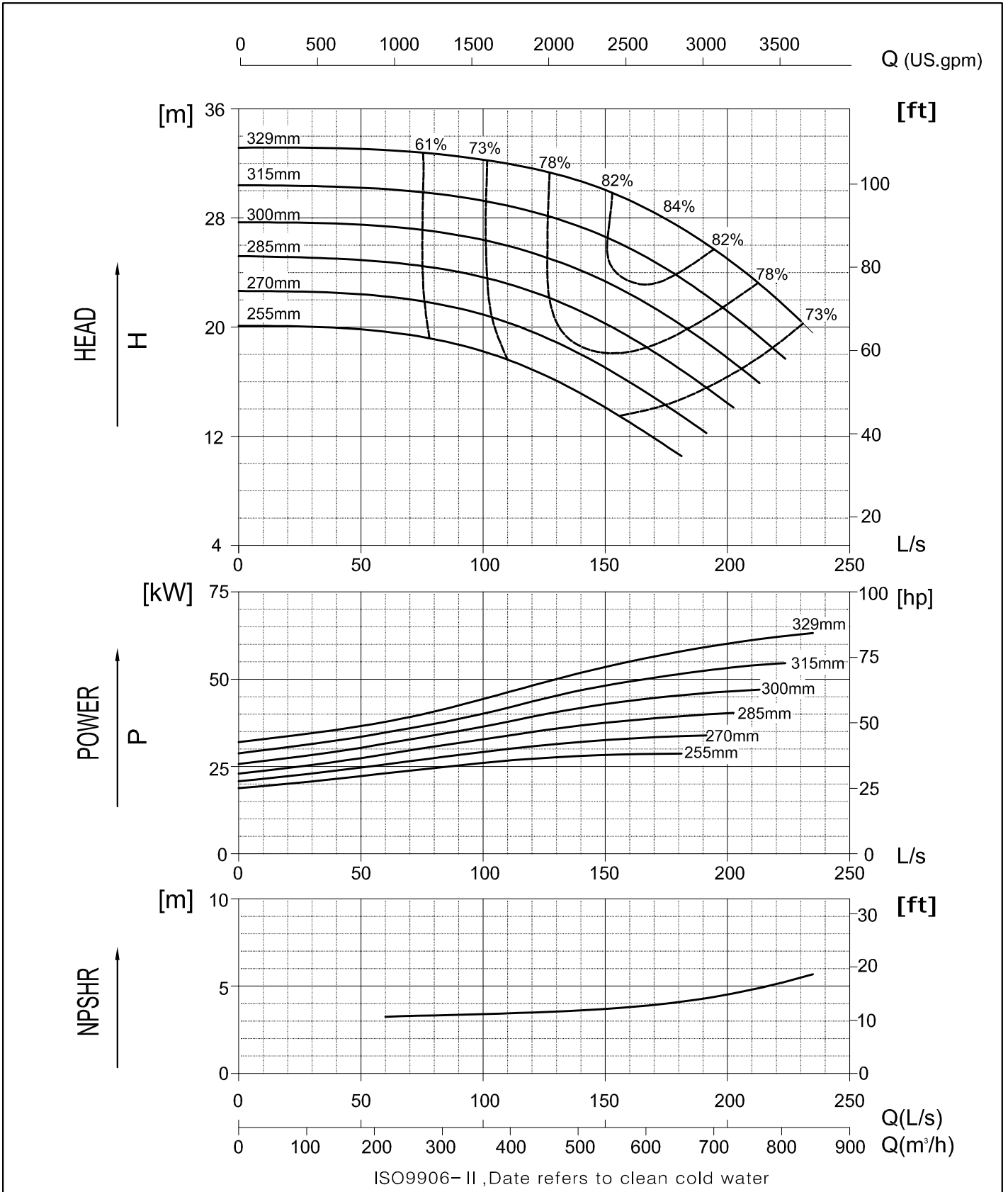

**NW200-400**  
1450 RPM

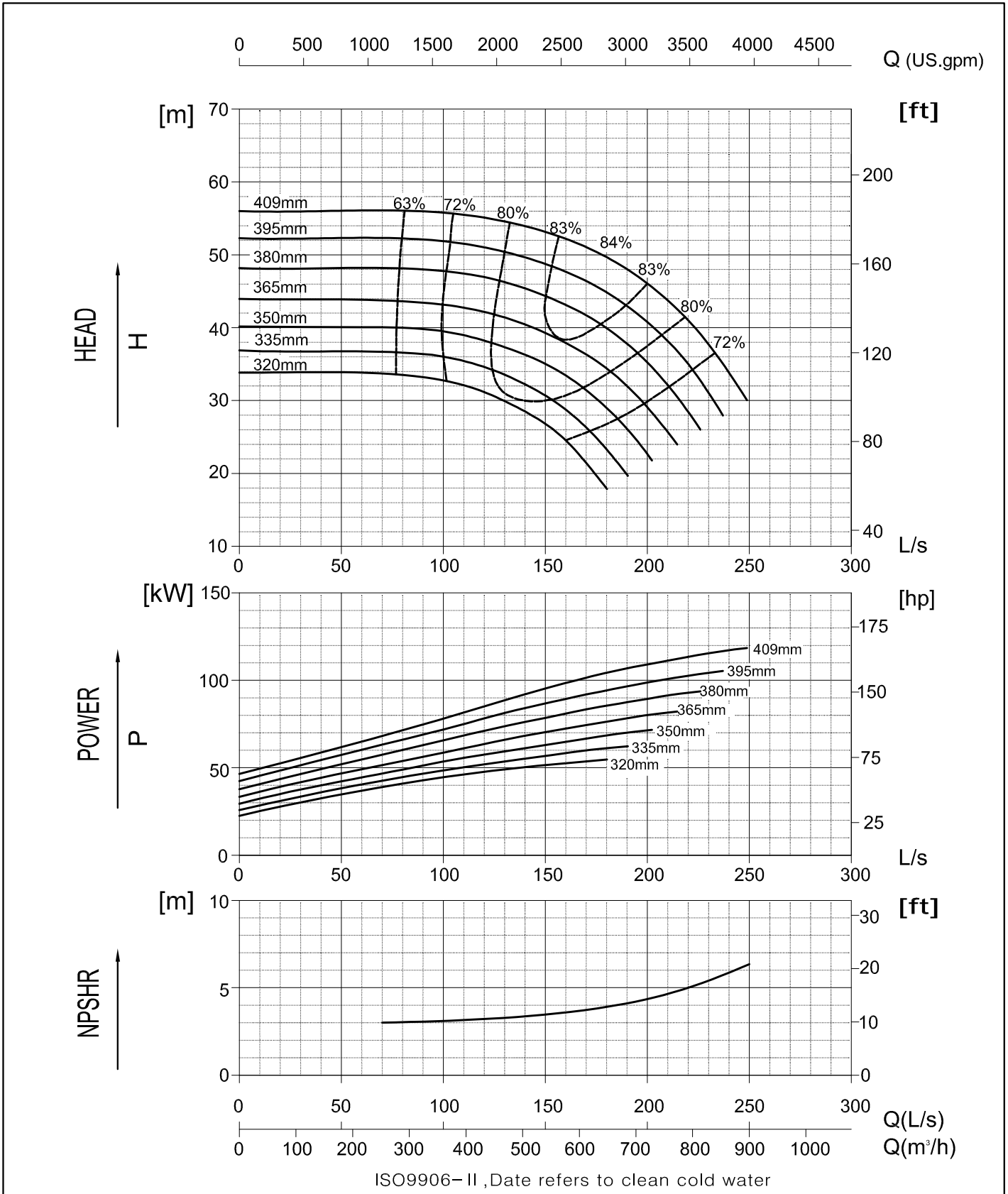

# NW250-320

1450 RPM

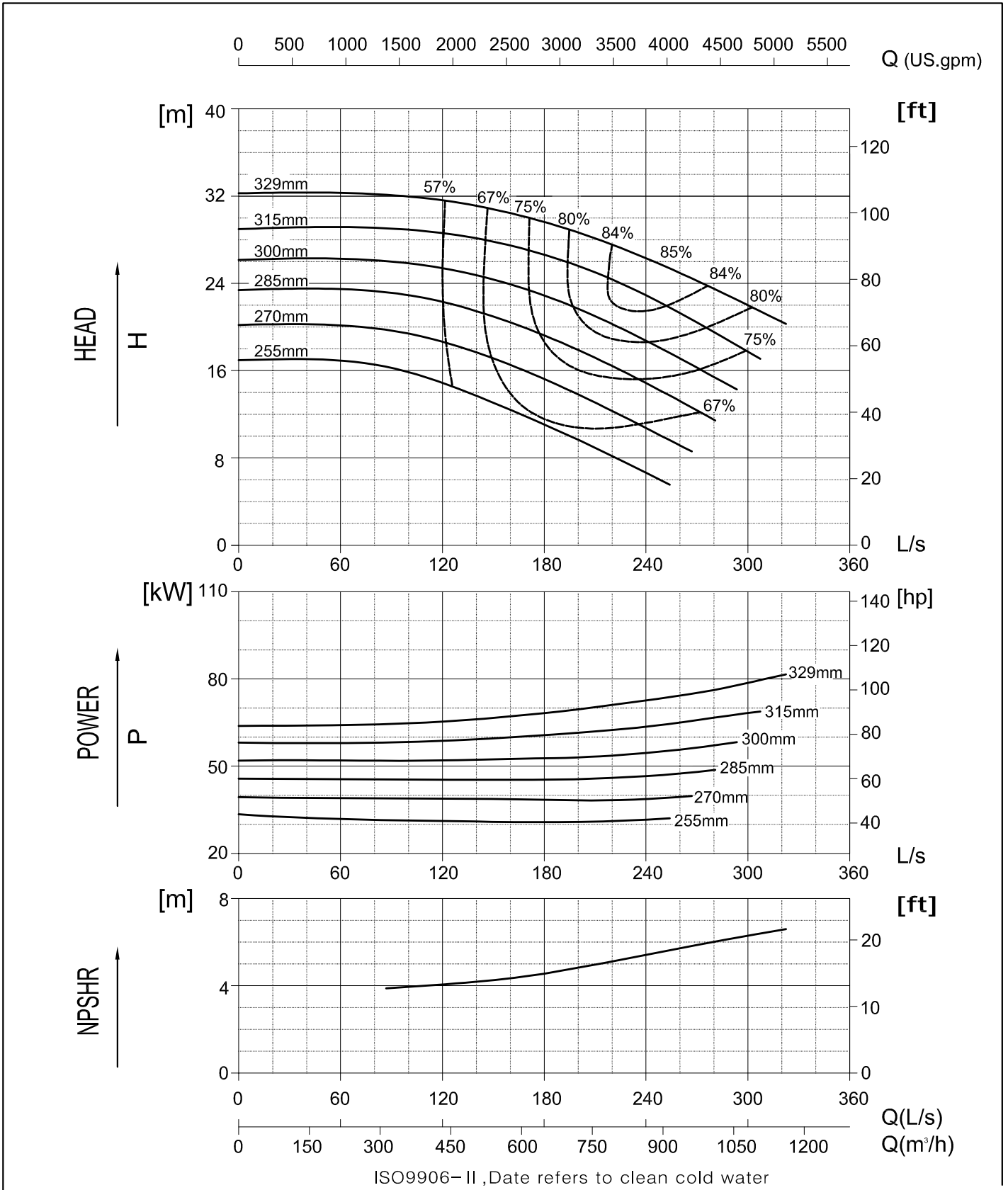

# NW250-400

1450 RPM

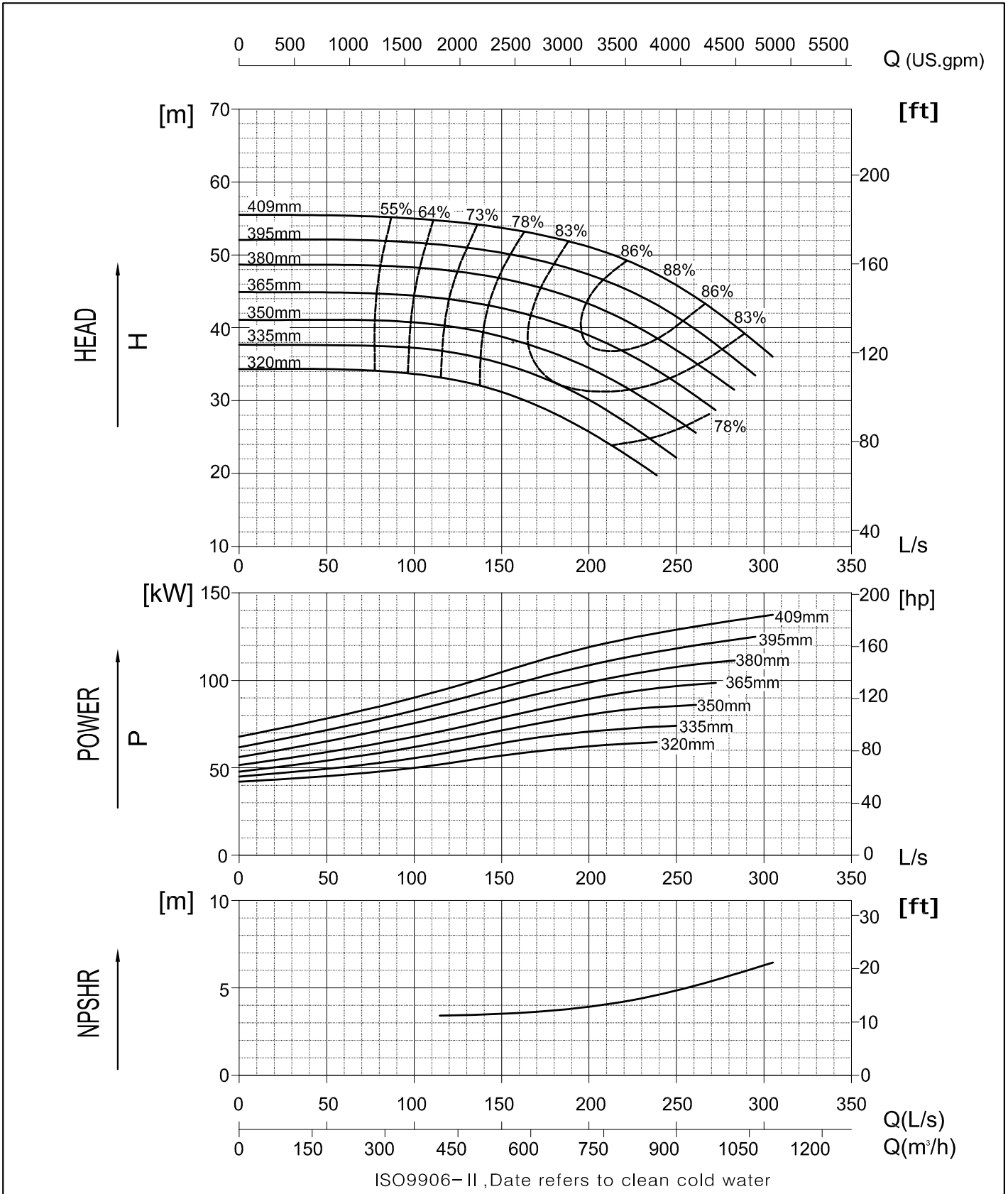

**NW32-125**  
2900 RPM

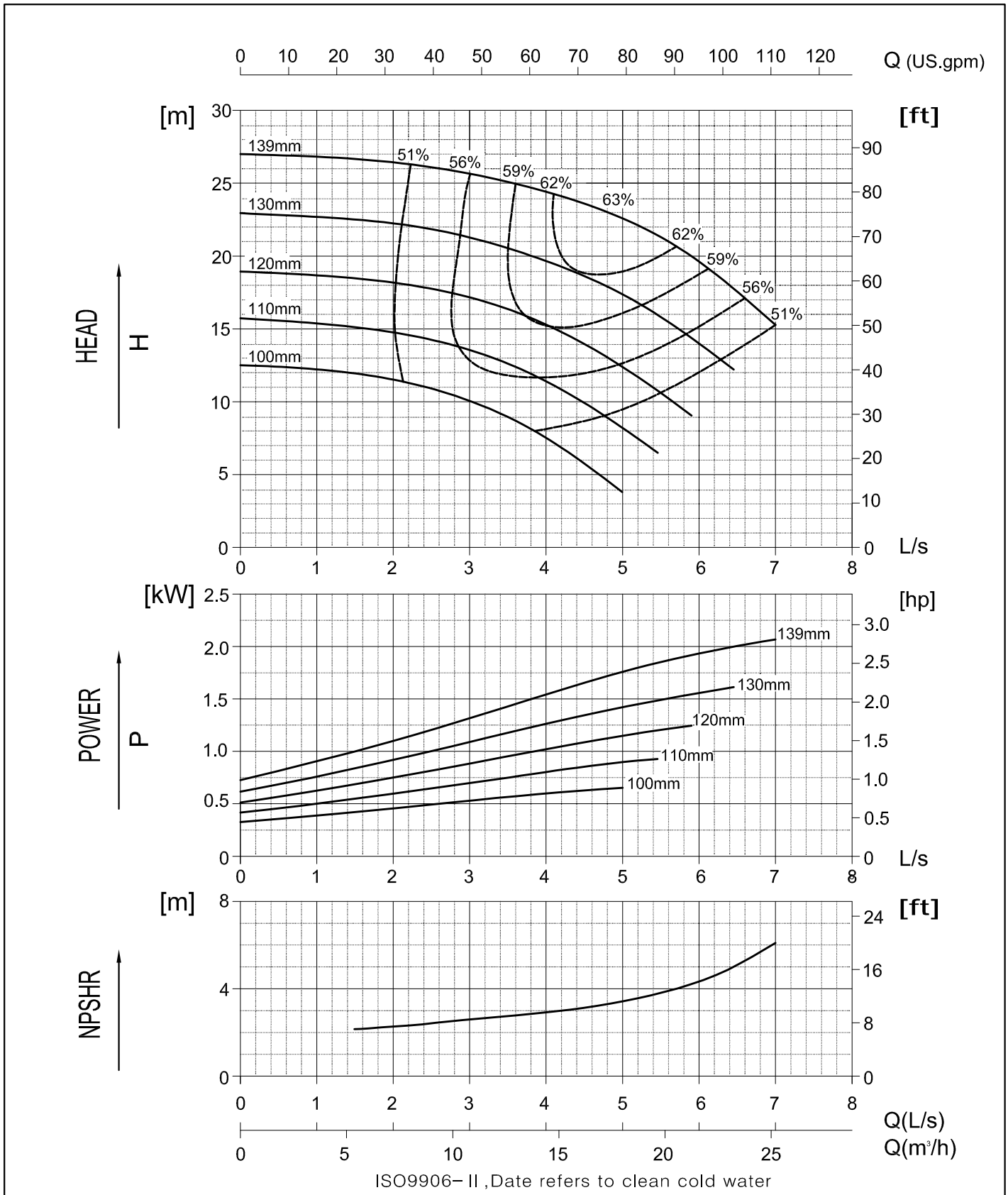

**NW32-160**  
2900 RPM

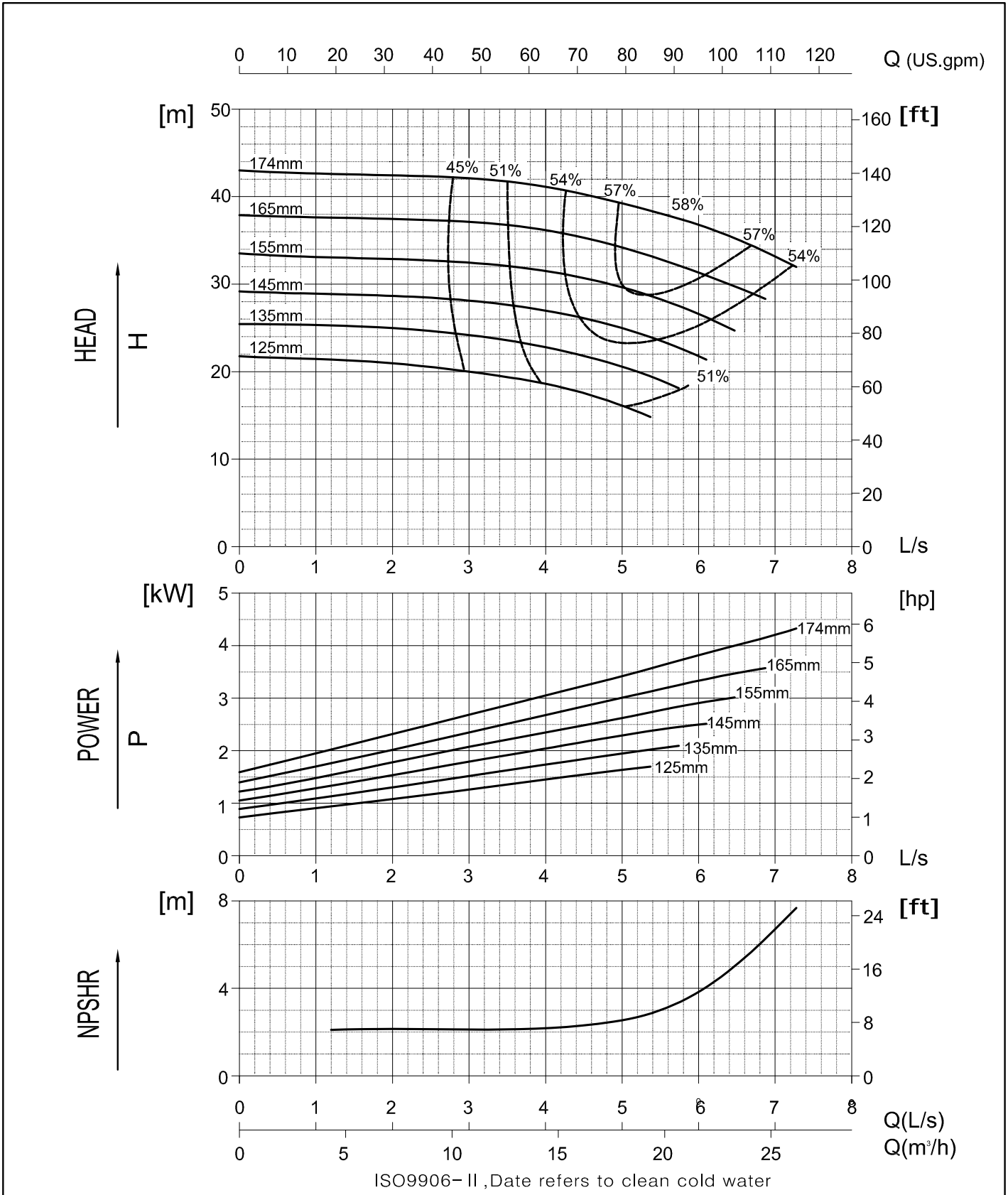

**NW32-200**  
2900 RPM

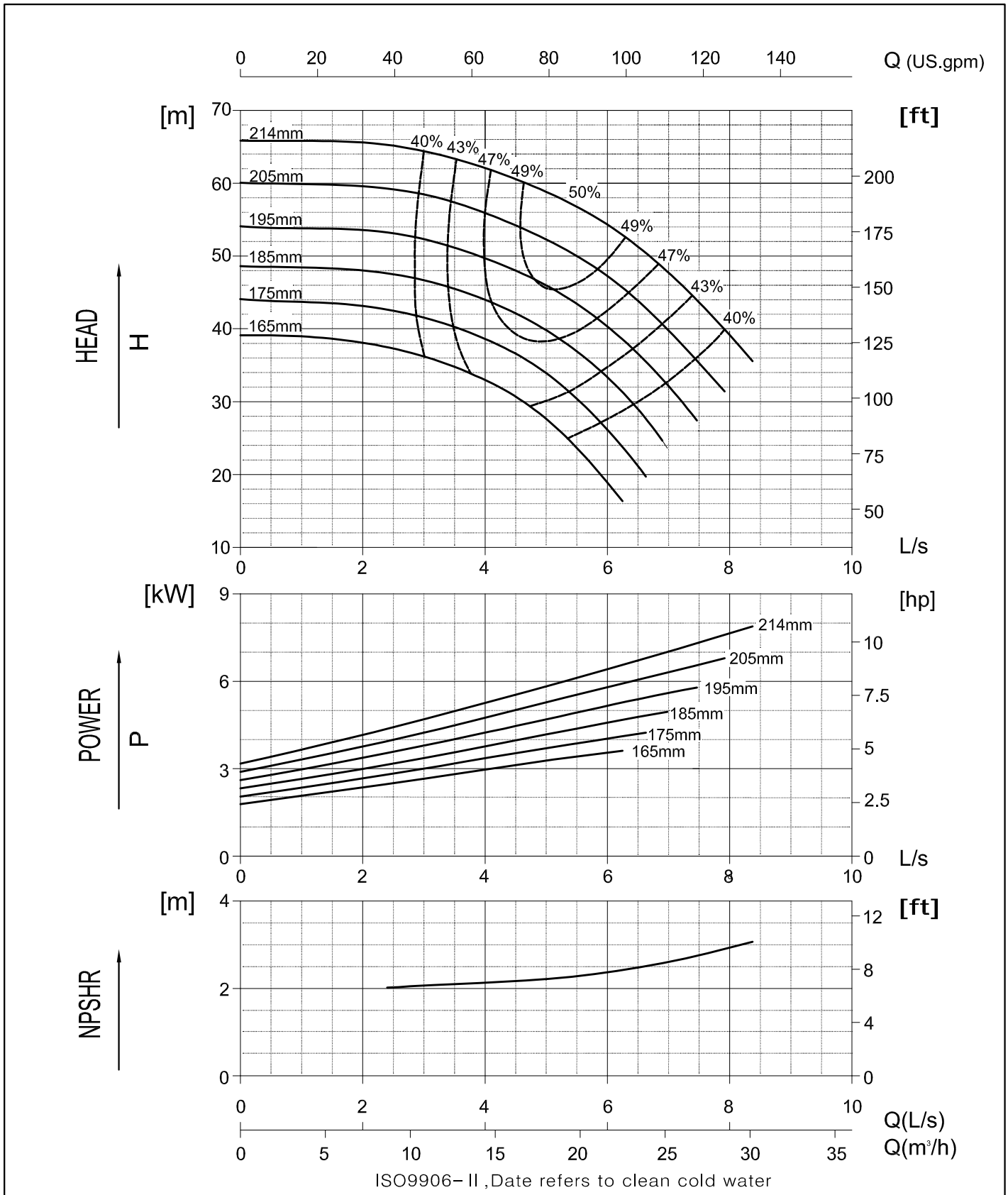

**NW32-250**  
2900 RPM

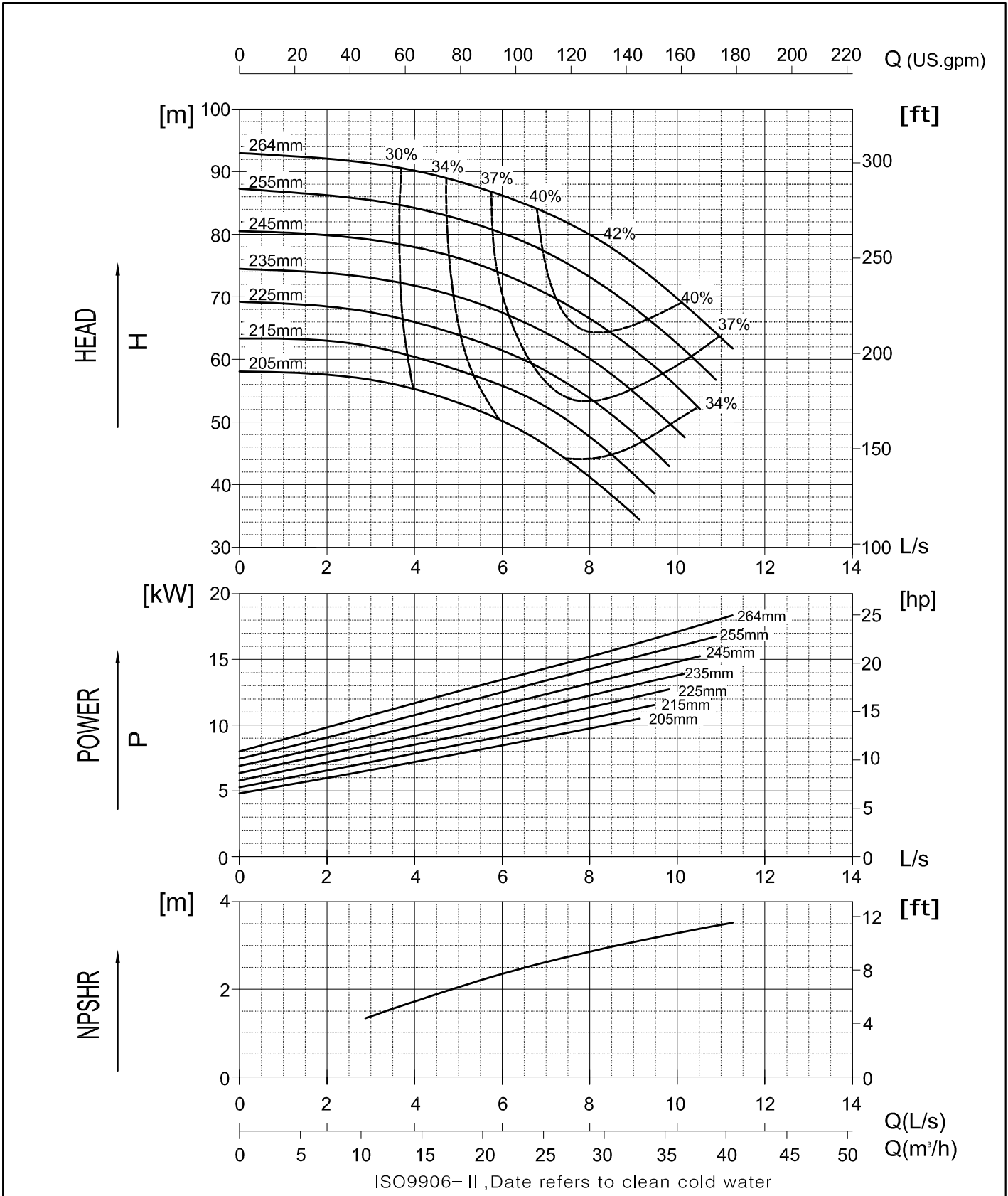

**NW40-125**  
2900 RPM

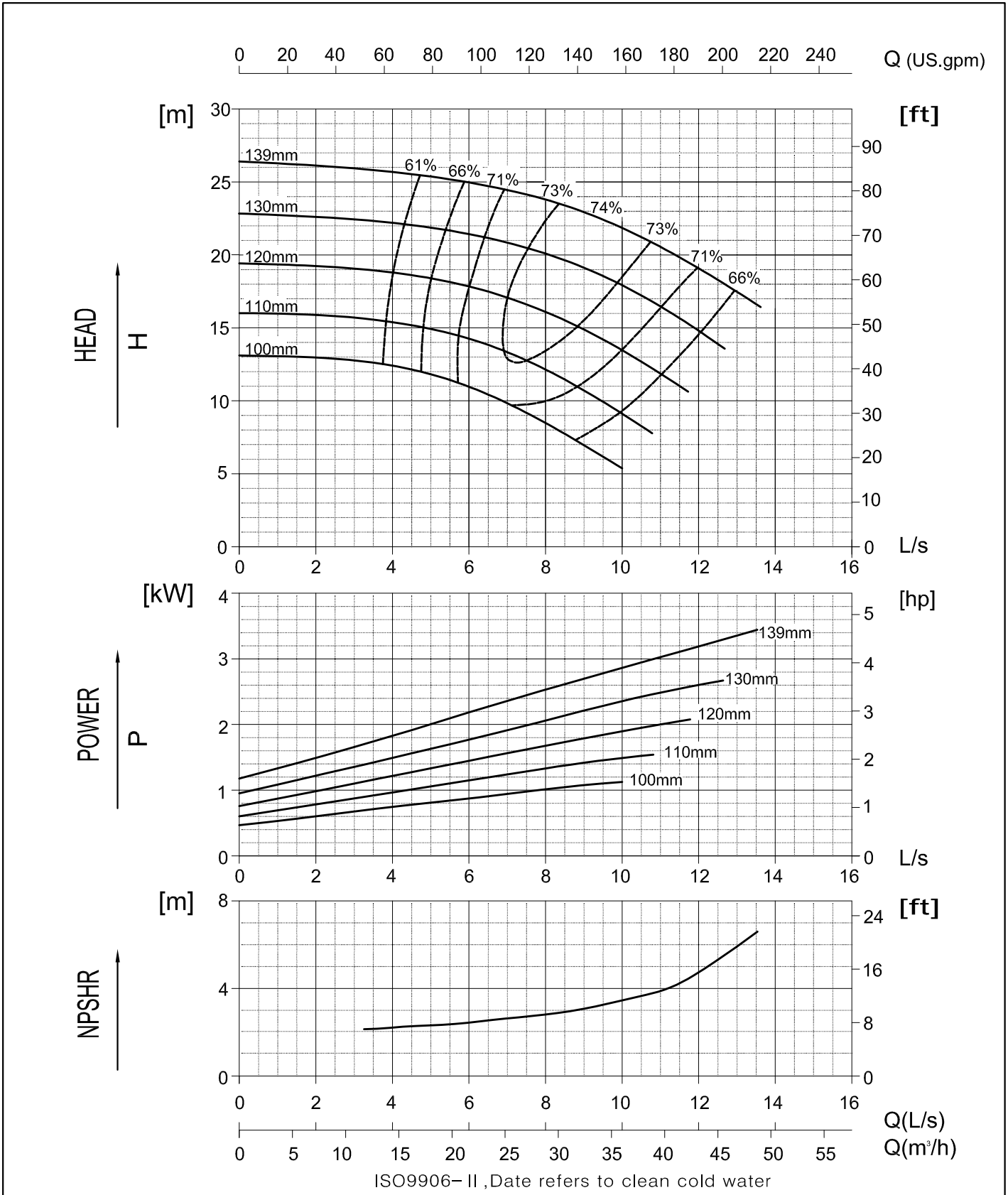

**NW40-160**  
2900 RPM

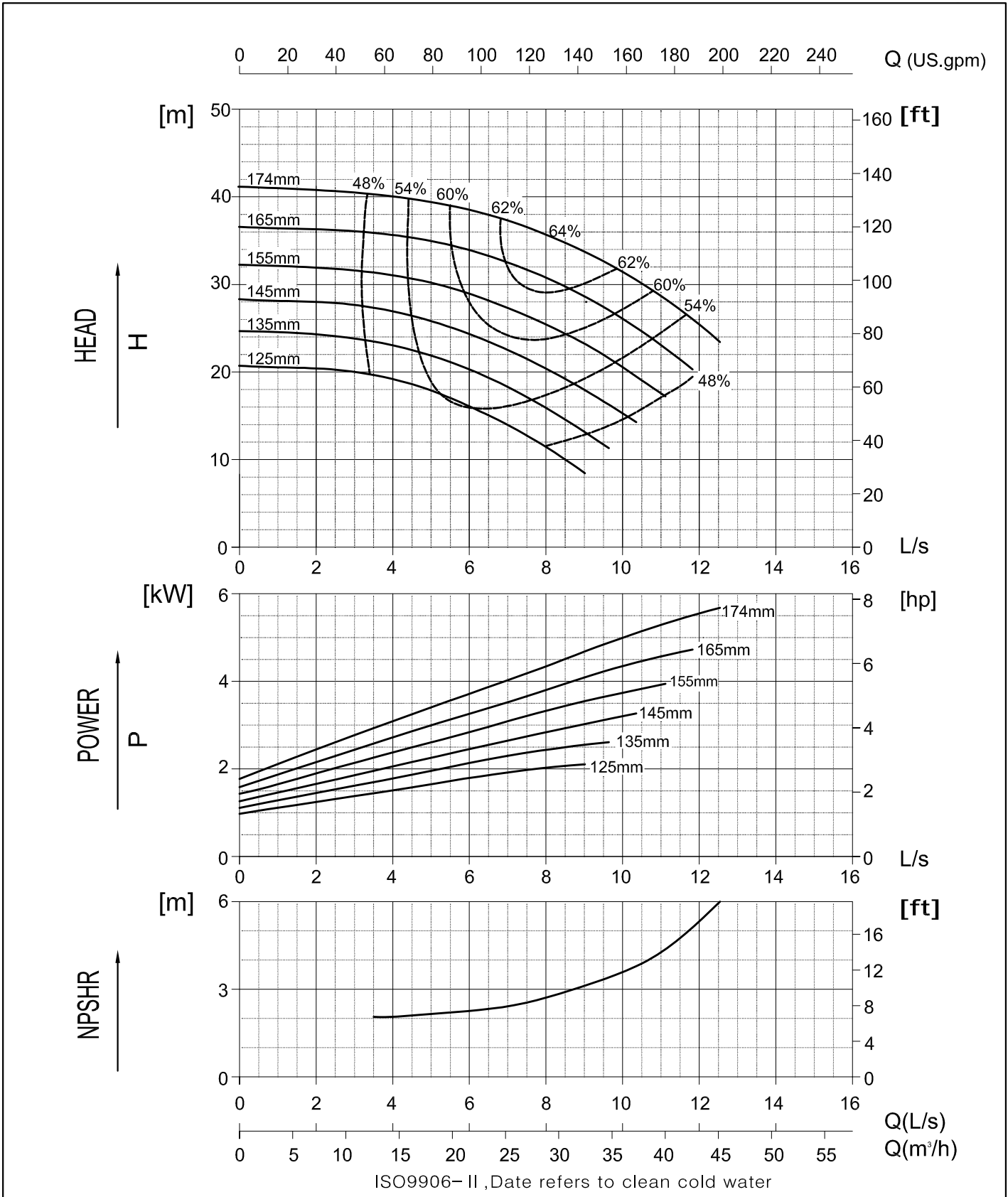

**NW40-200**  
2900 RPM

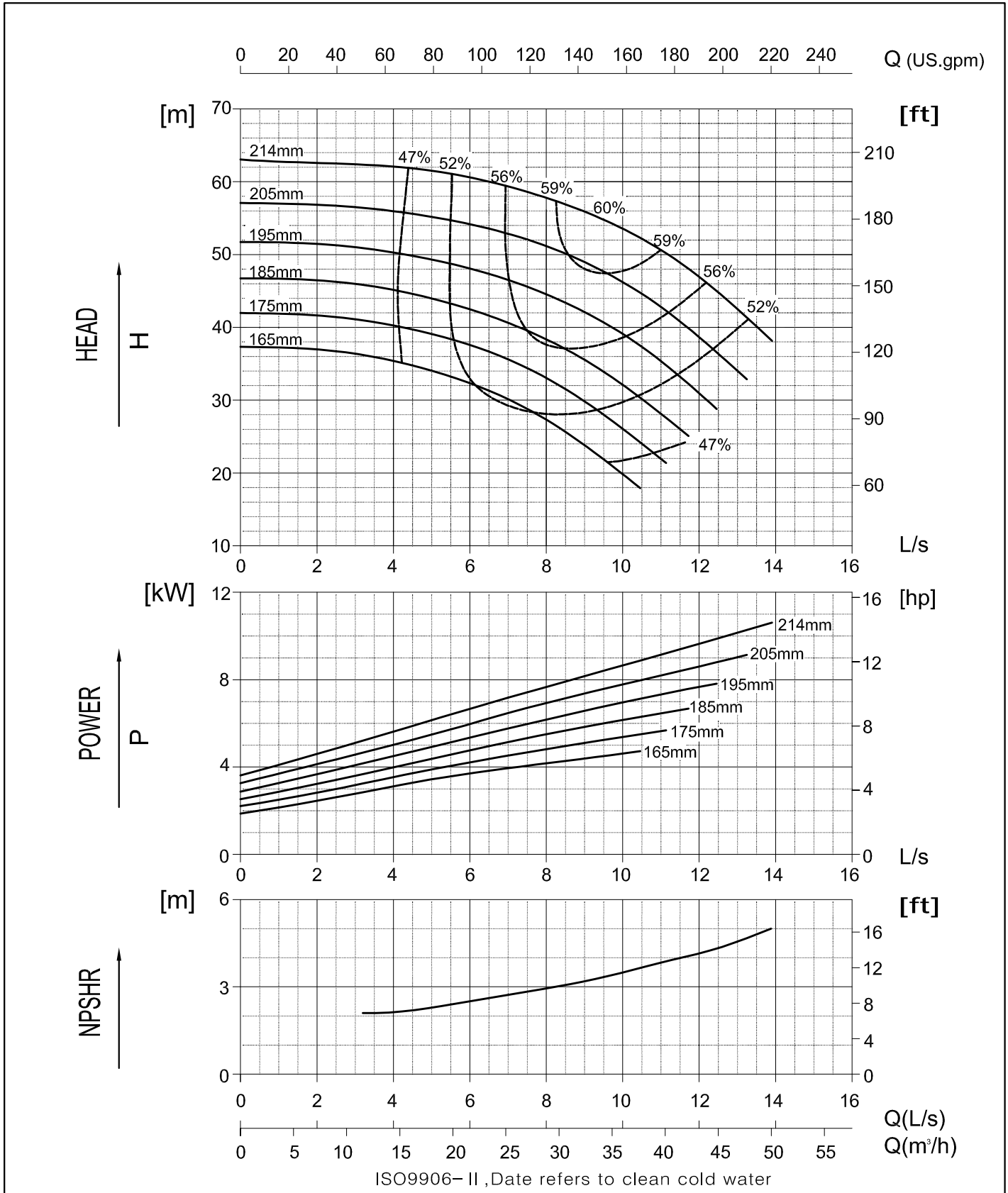

**NW40-250**  
2900 RPM

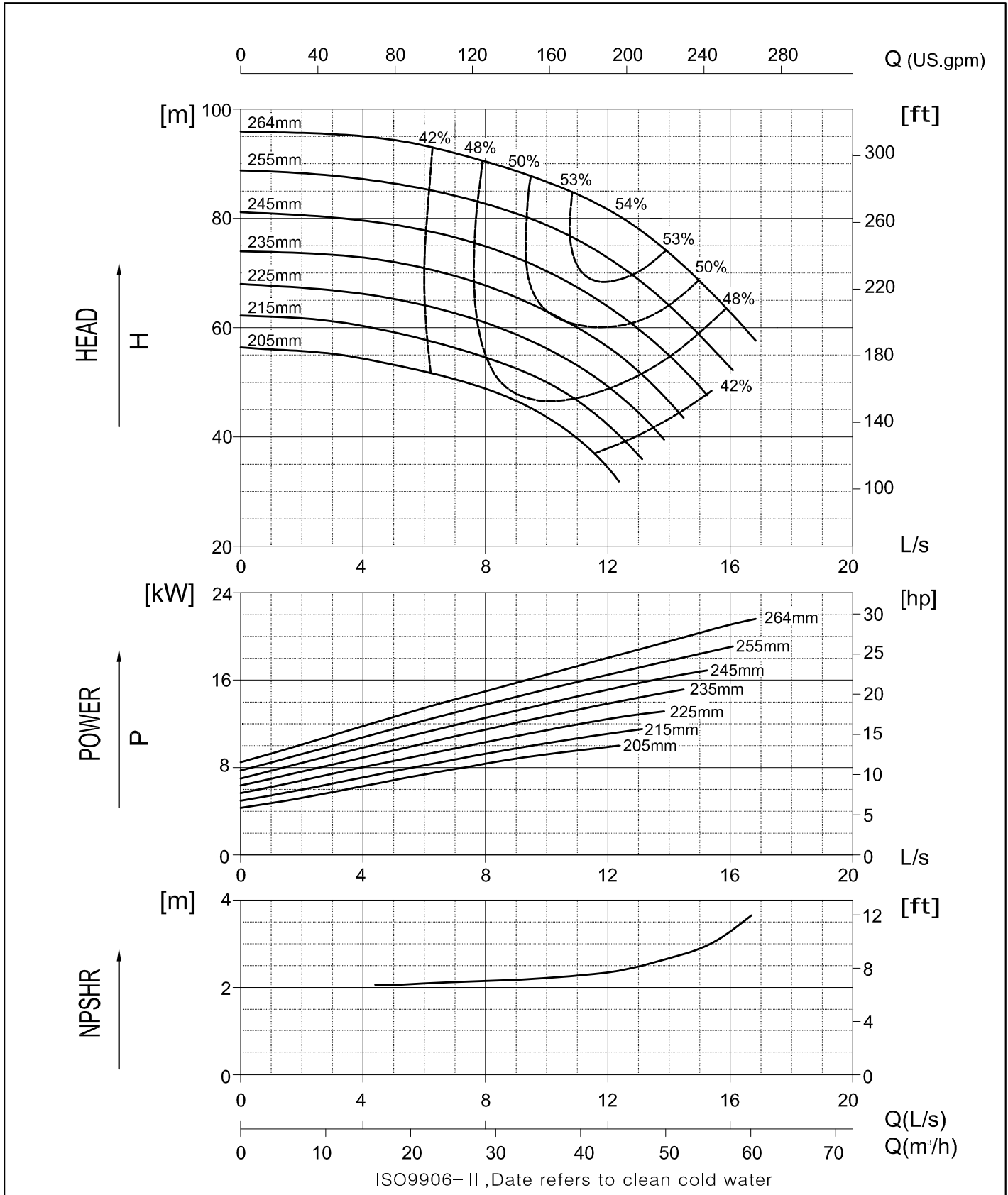

# NW40-315G

2900 RPM

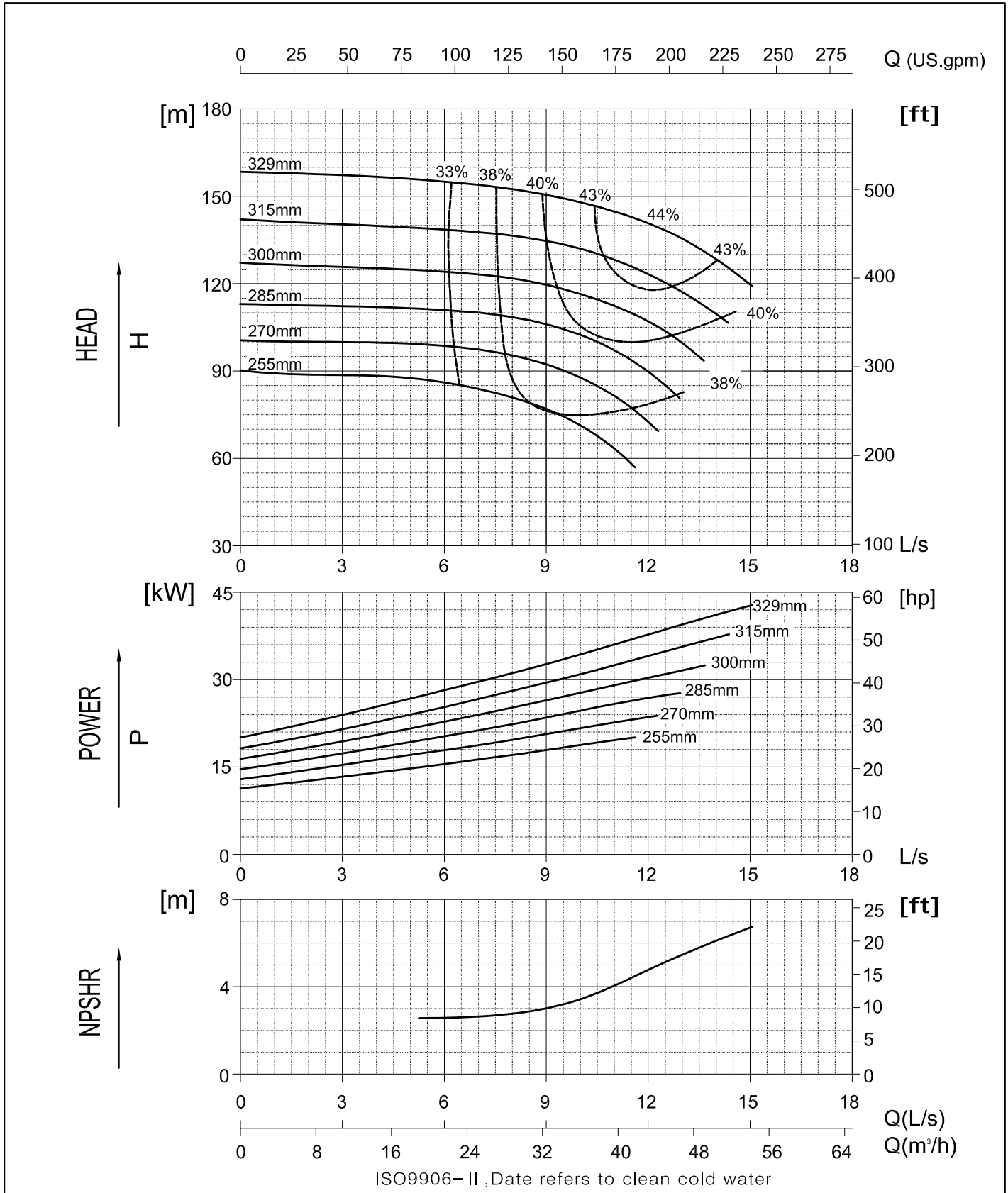

**NW50-125**  
2900 RPM

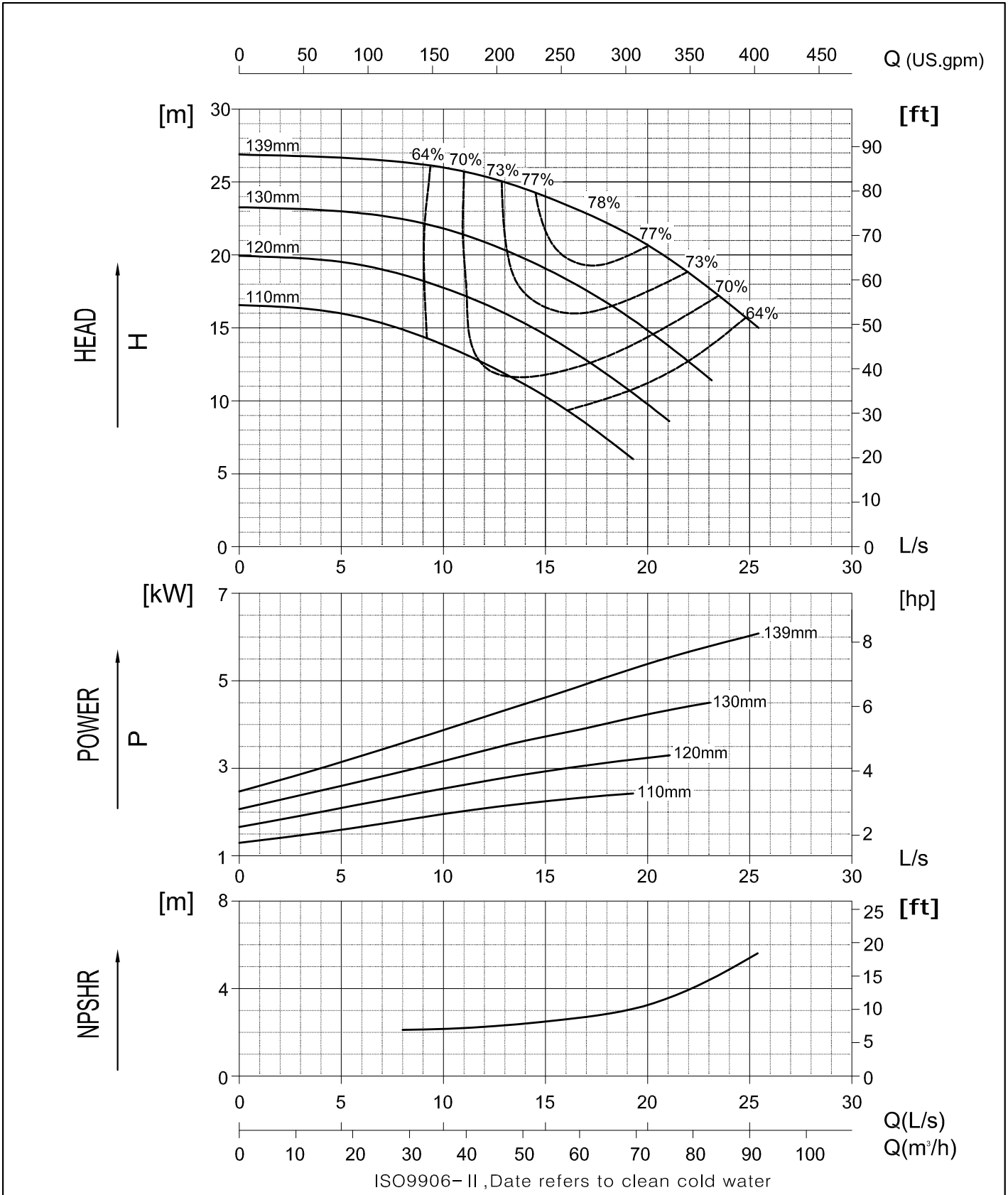

**NW50-160**  
2900 RPM

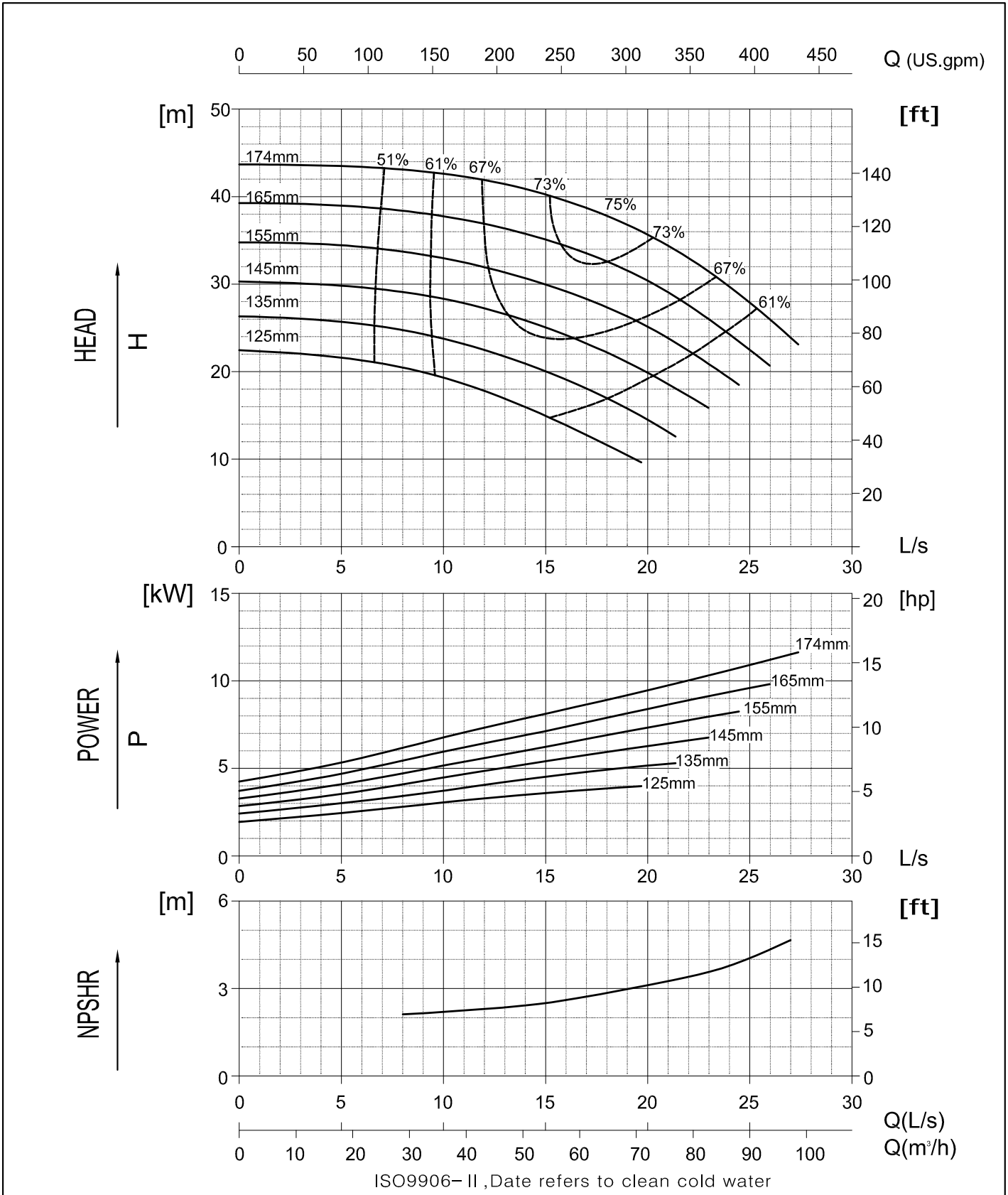

**NW50-200**  
2900 RPM

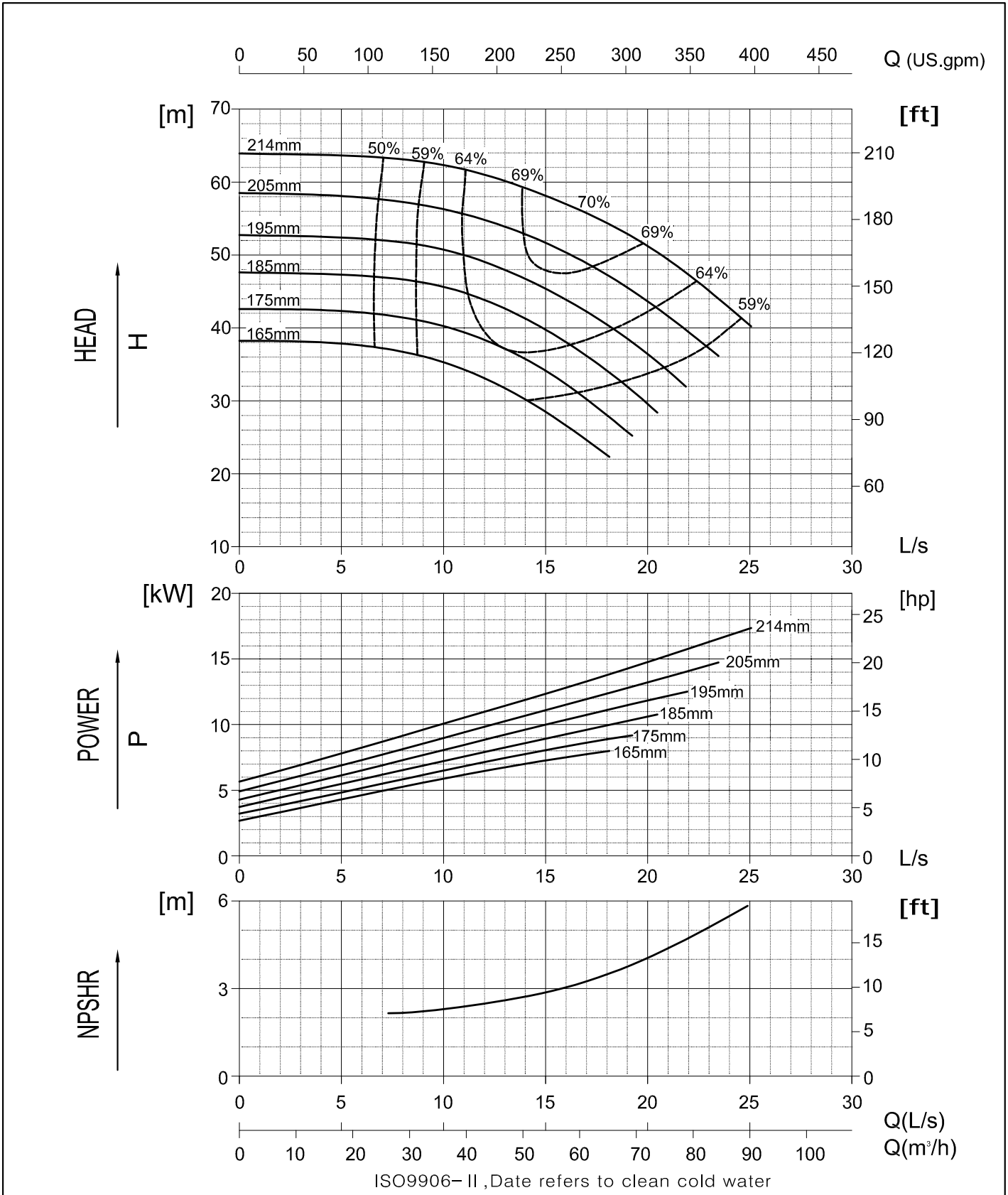

**NW50-250**  
2900 RPM

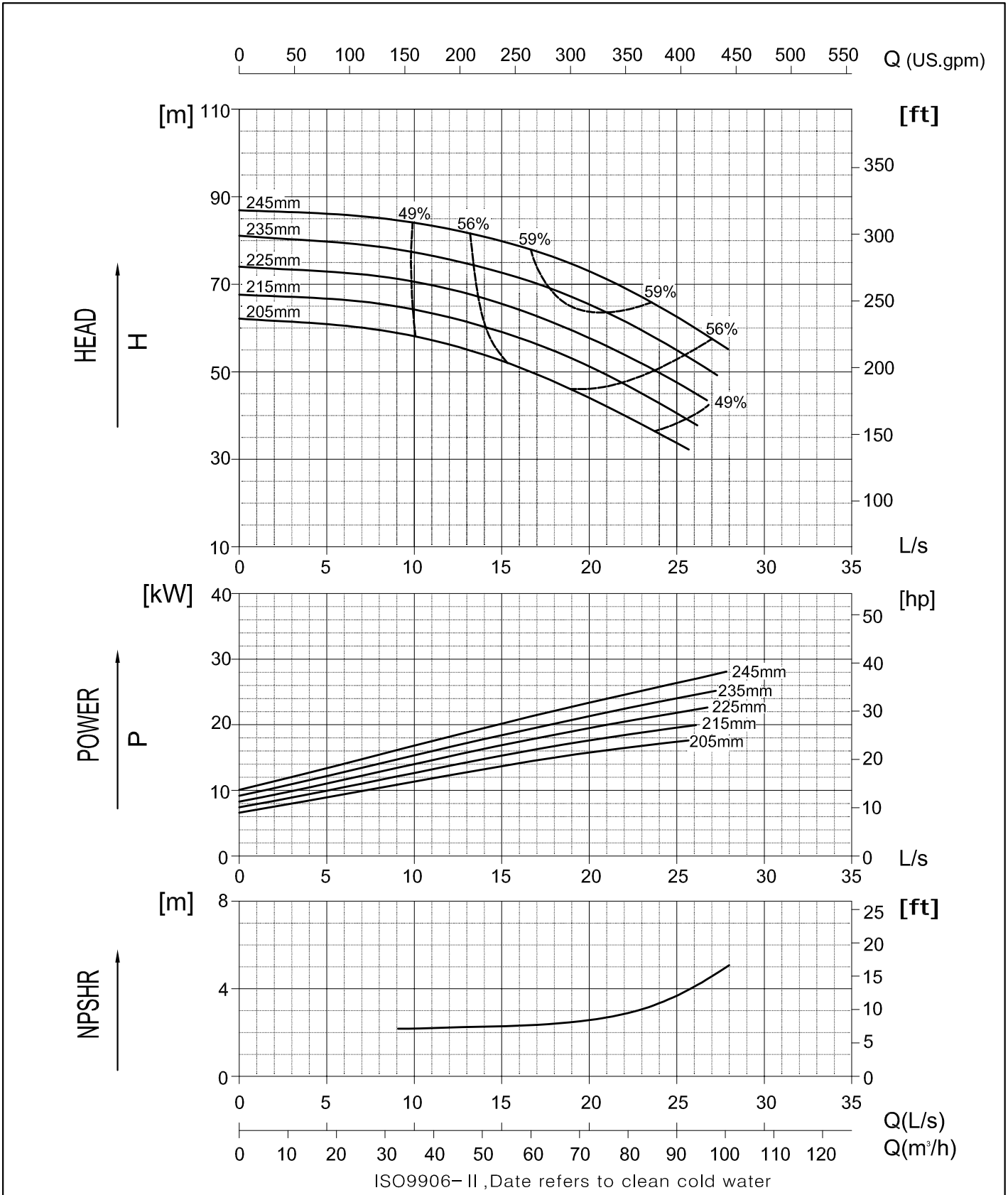

# NW50-250G

2900 RPM

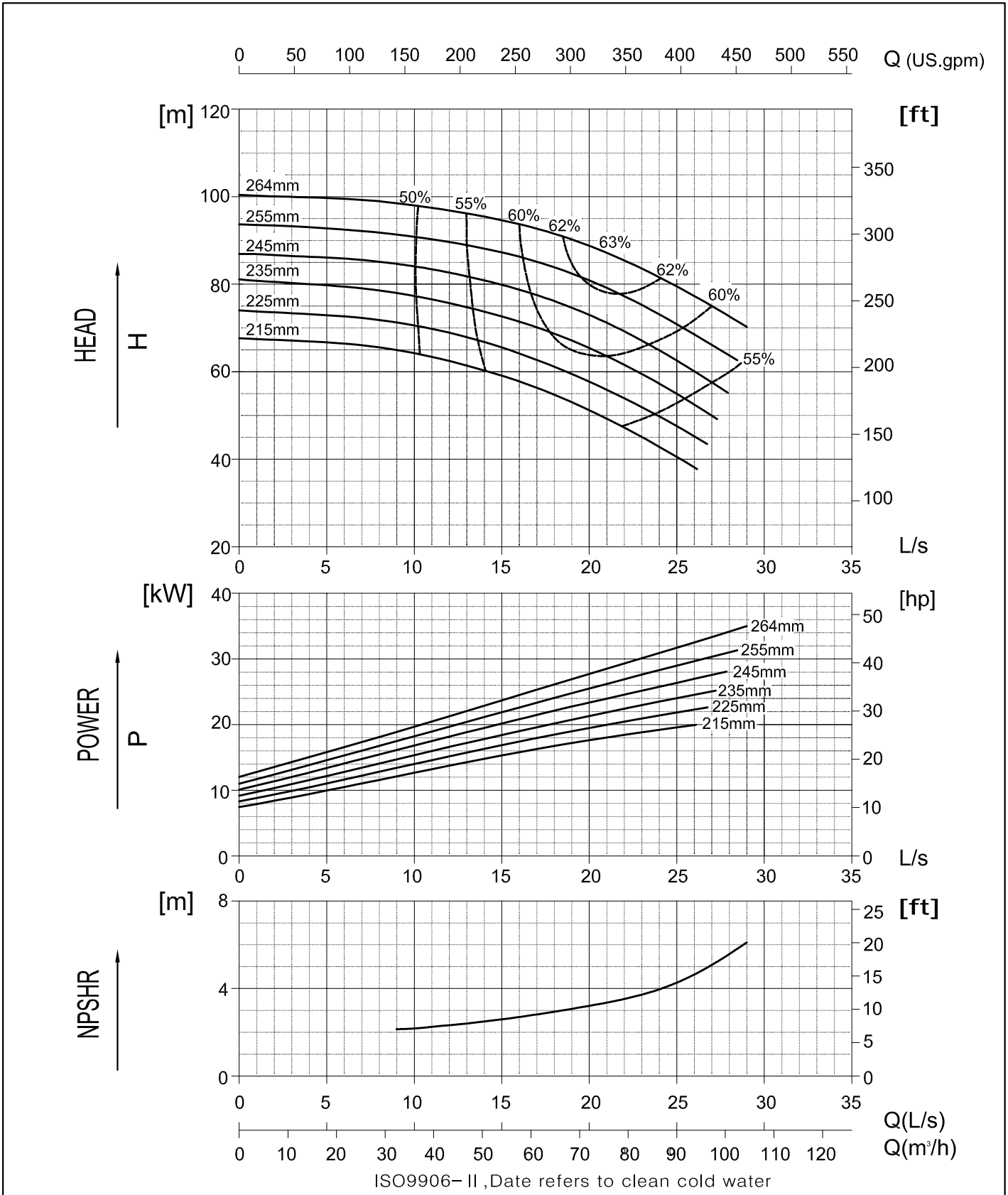

**NW50-315G**  
2900 RPM

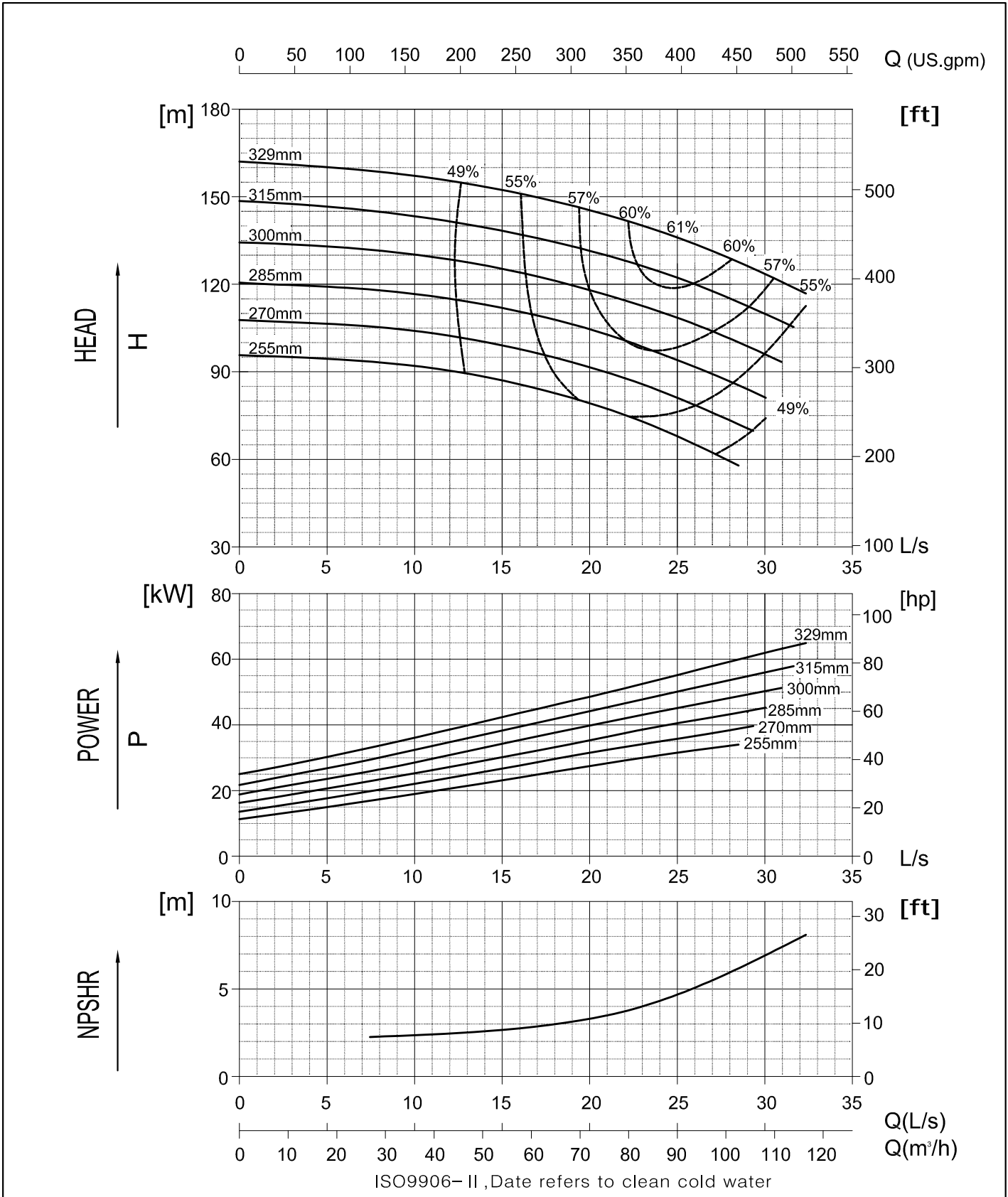

**NW65-125**  
2900 RPM

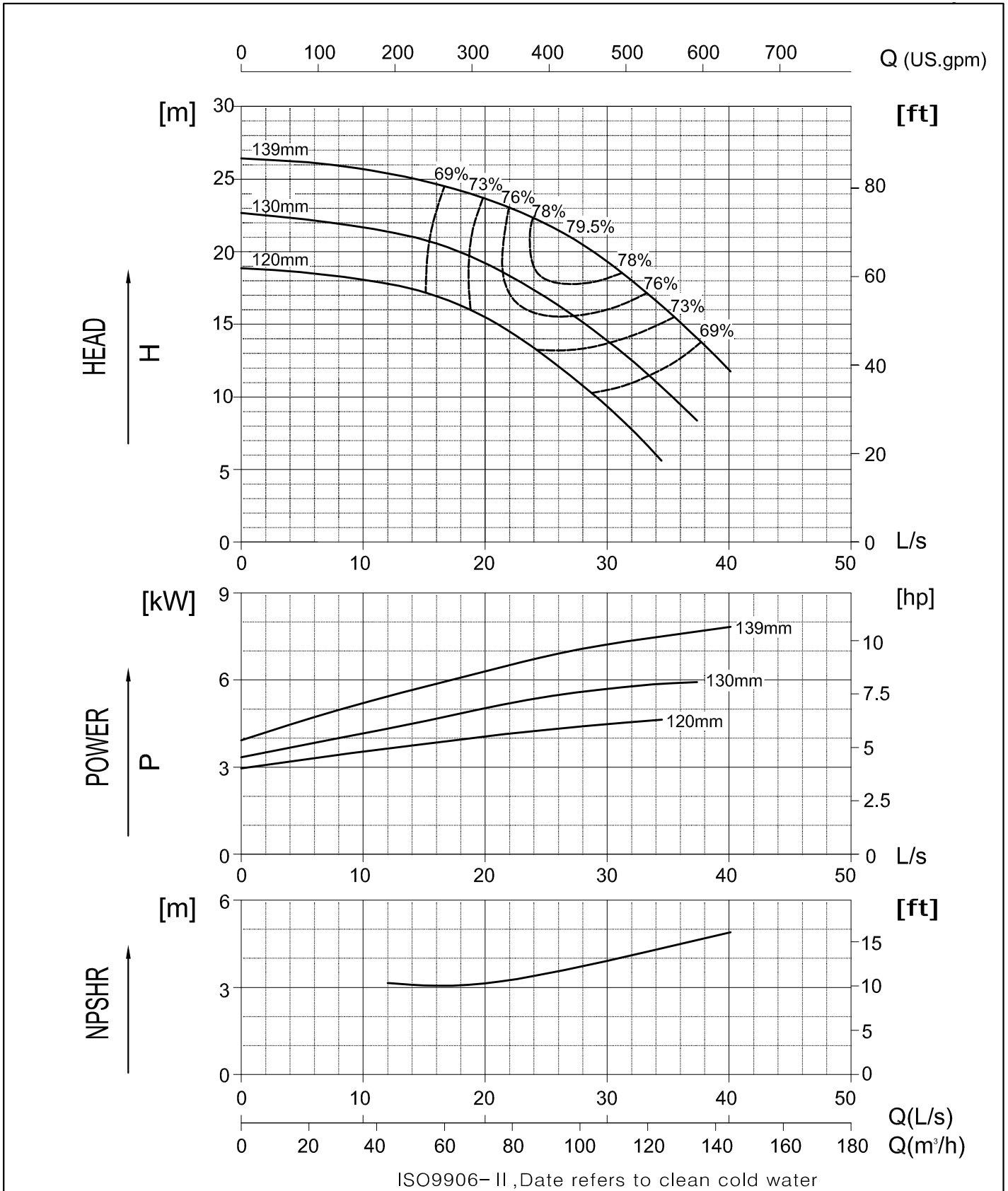

**NW65-160**  
2900 RPM

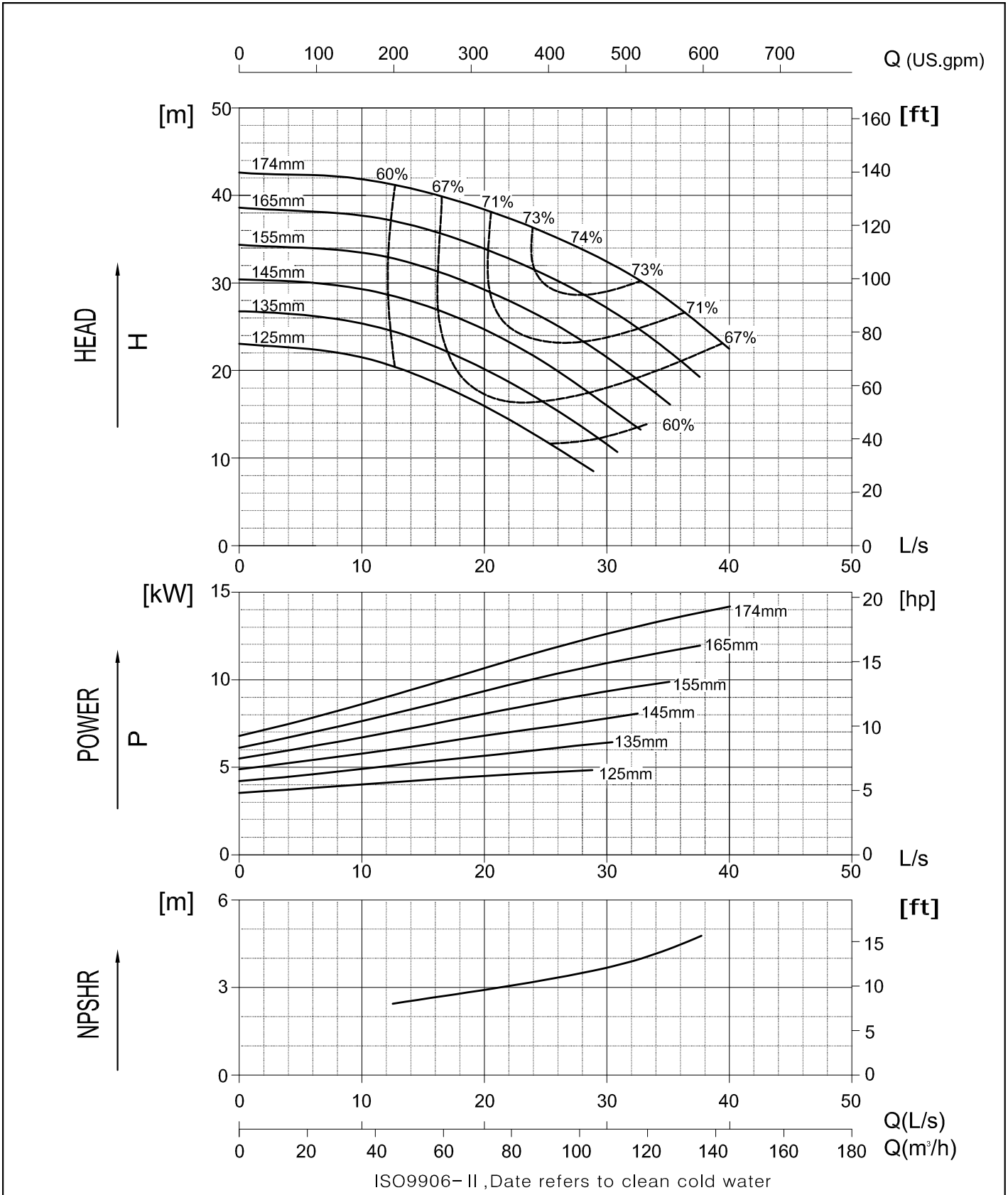

**NW65-200G**  
2900 RPM

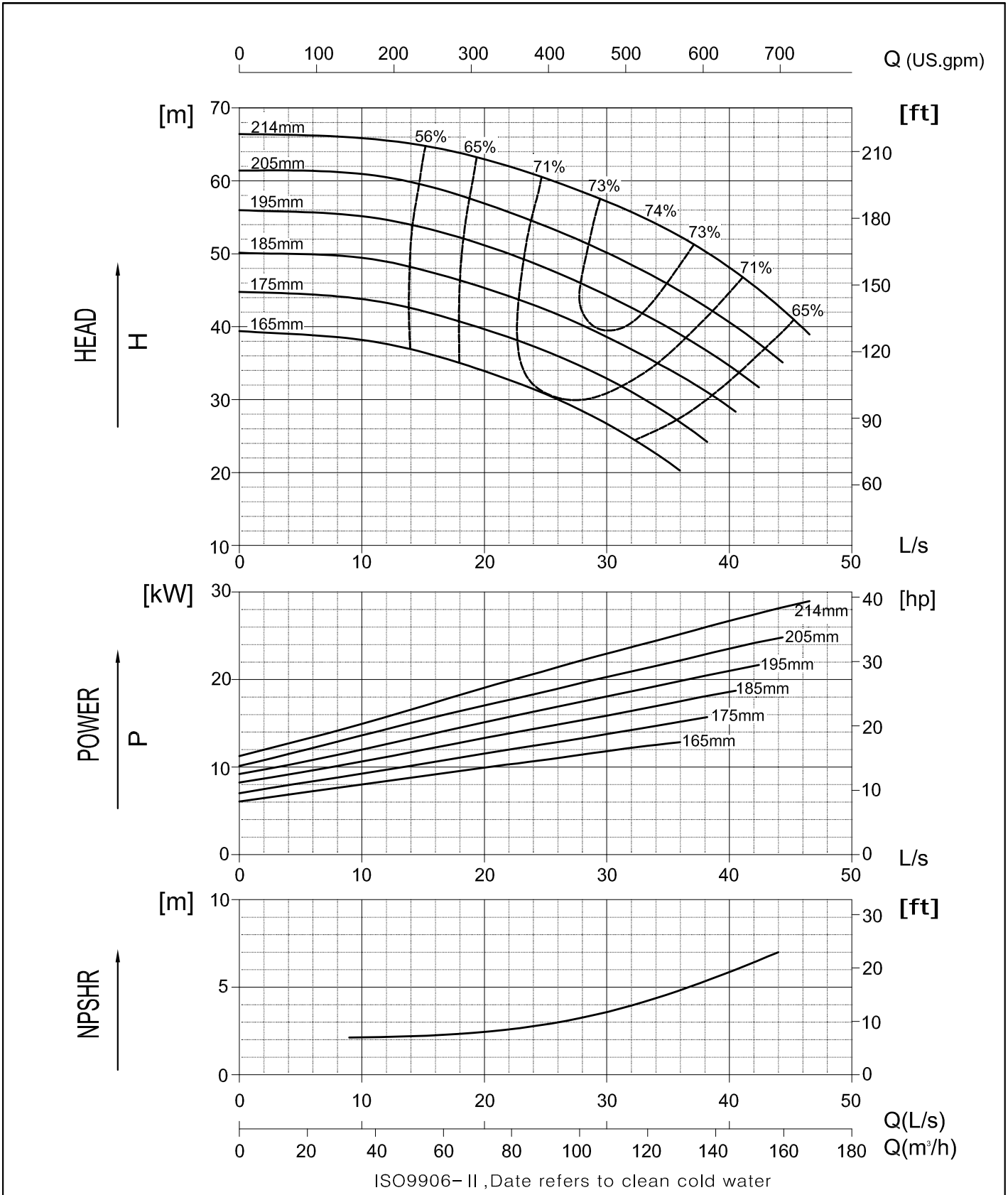

**NW65-250**  
2900 RPM

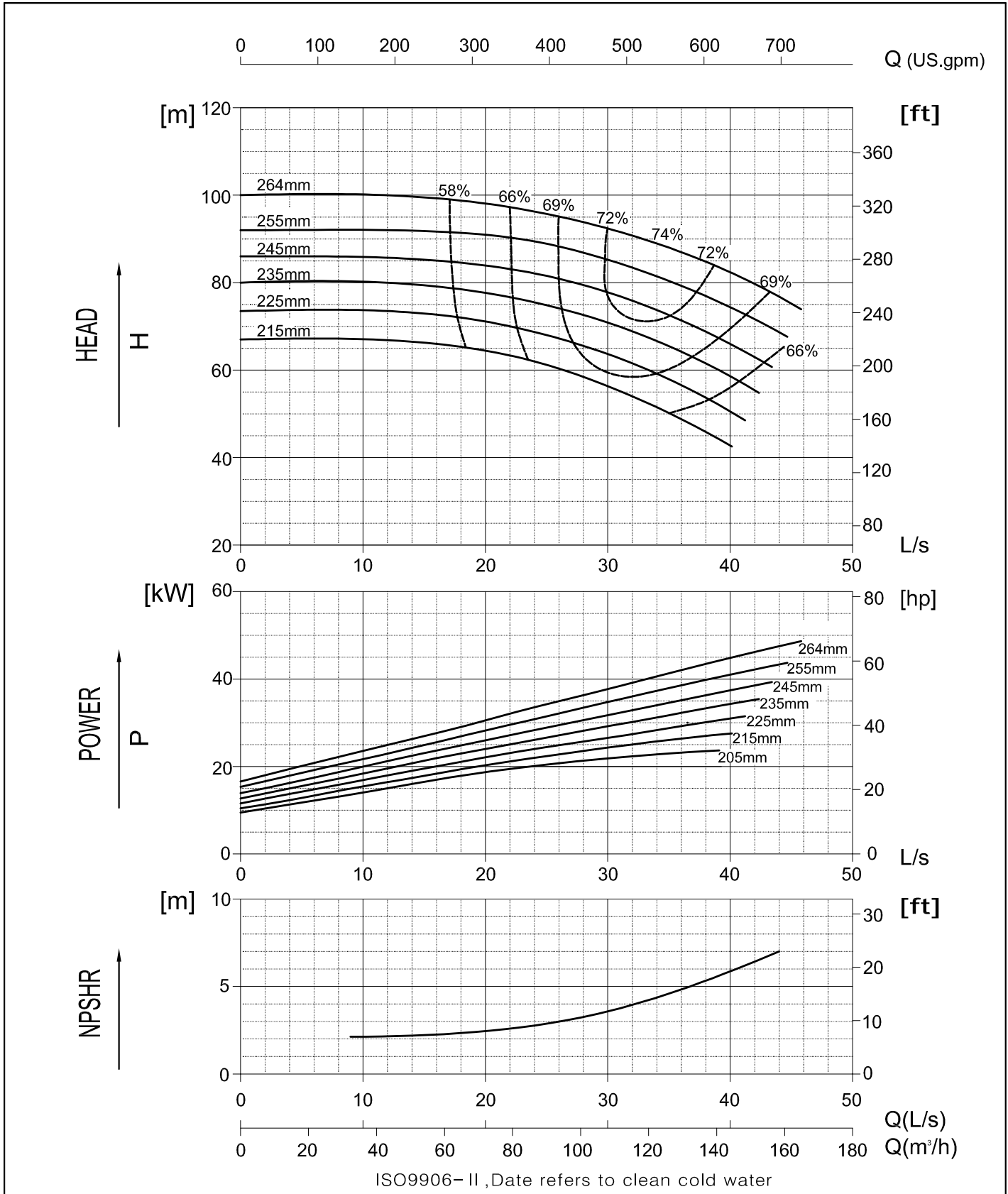

**NW65-320G**  
2900 RPM

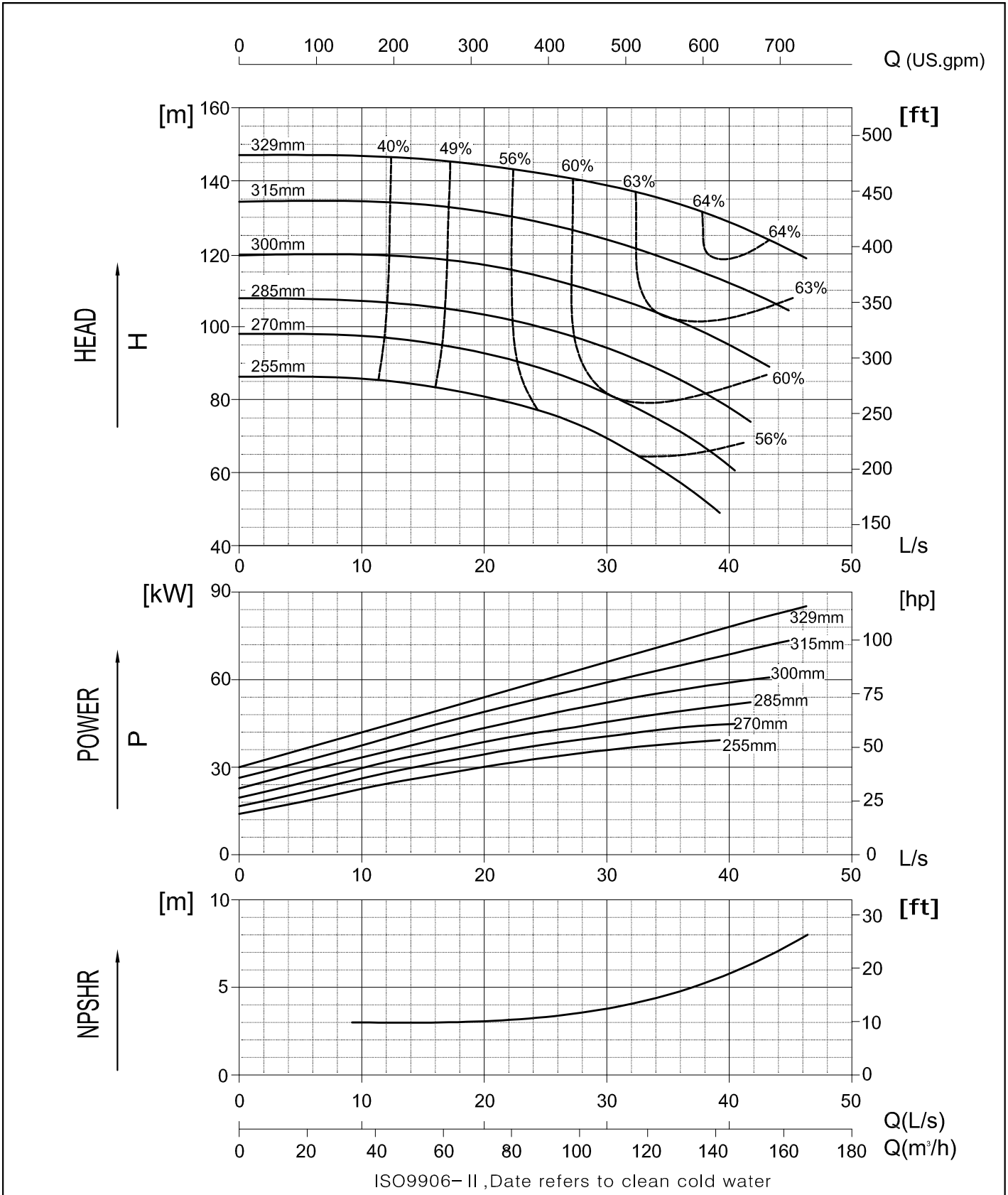

**NW80-160**  
2900 RPM

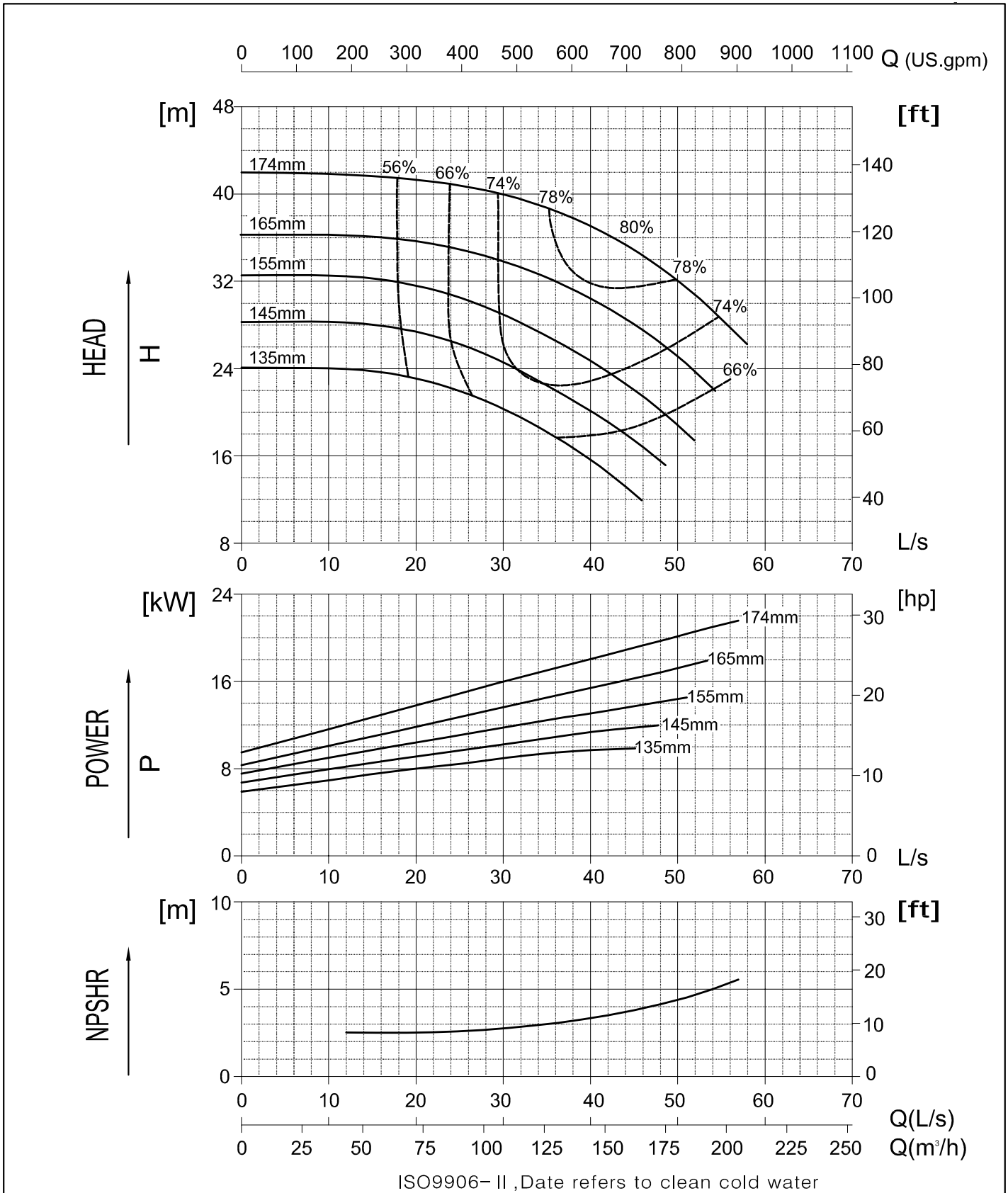

**NW80-200**  
2900 RPM

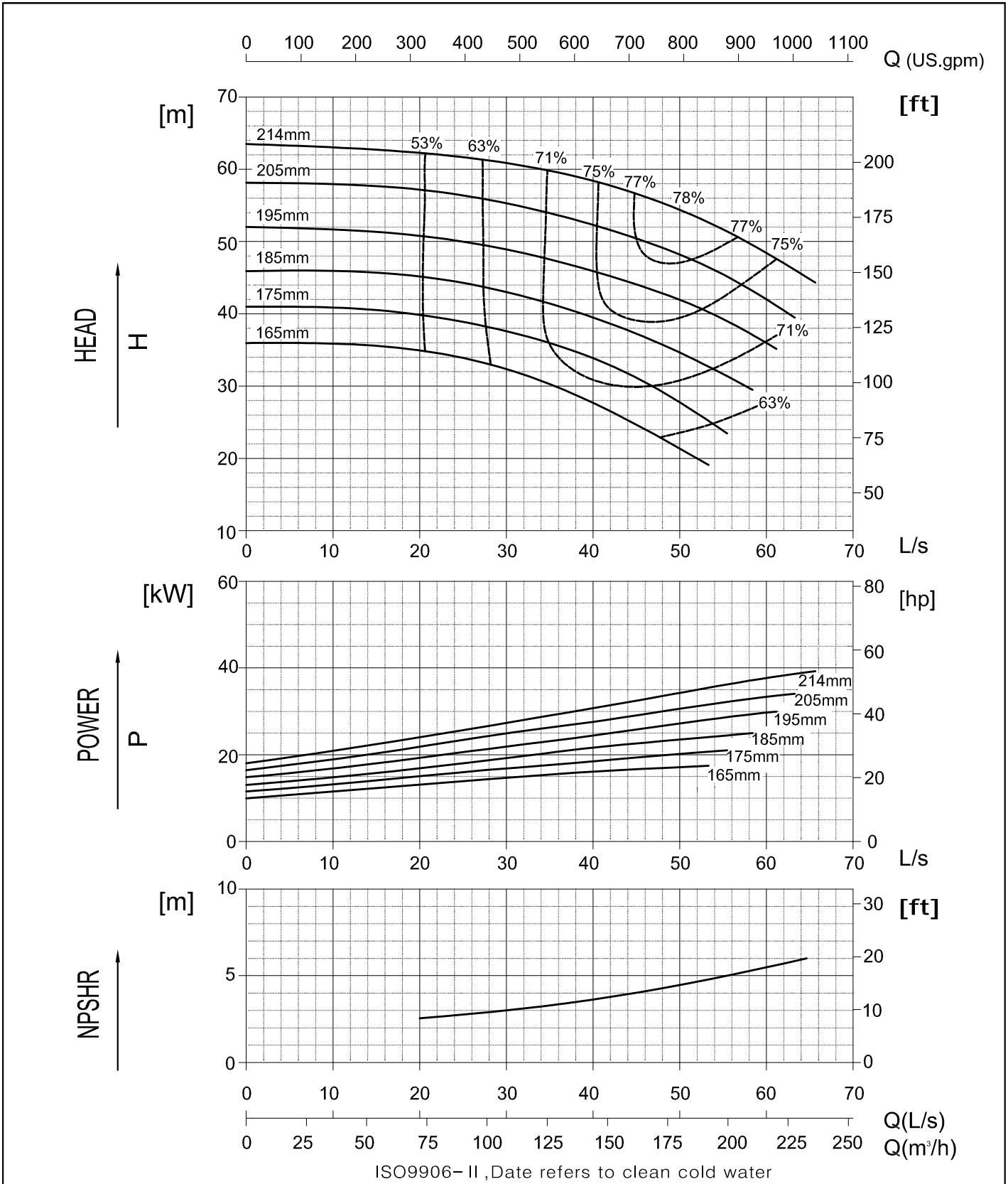

**NW80-250**  
2900 RPM

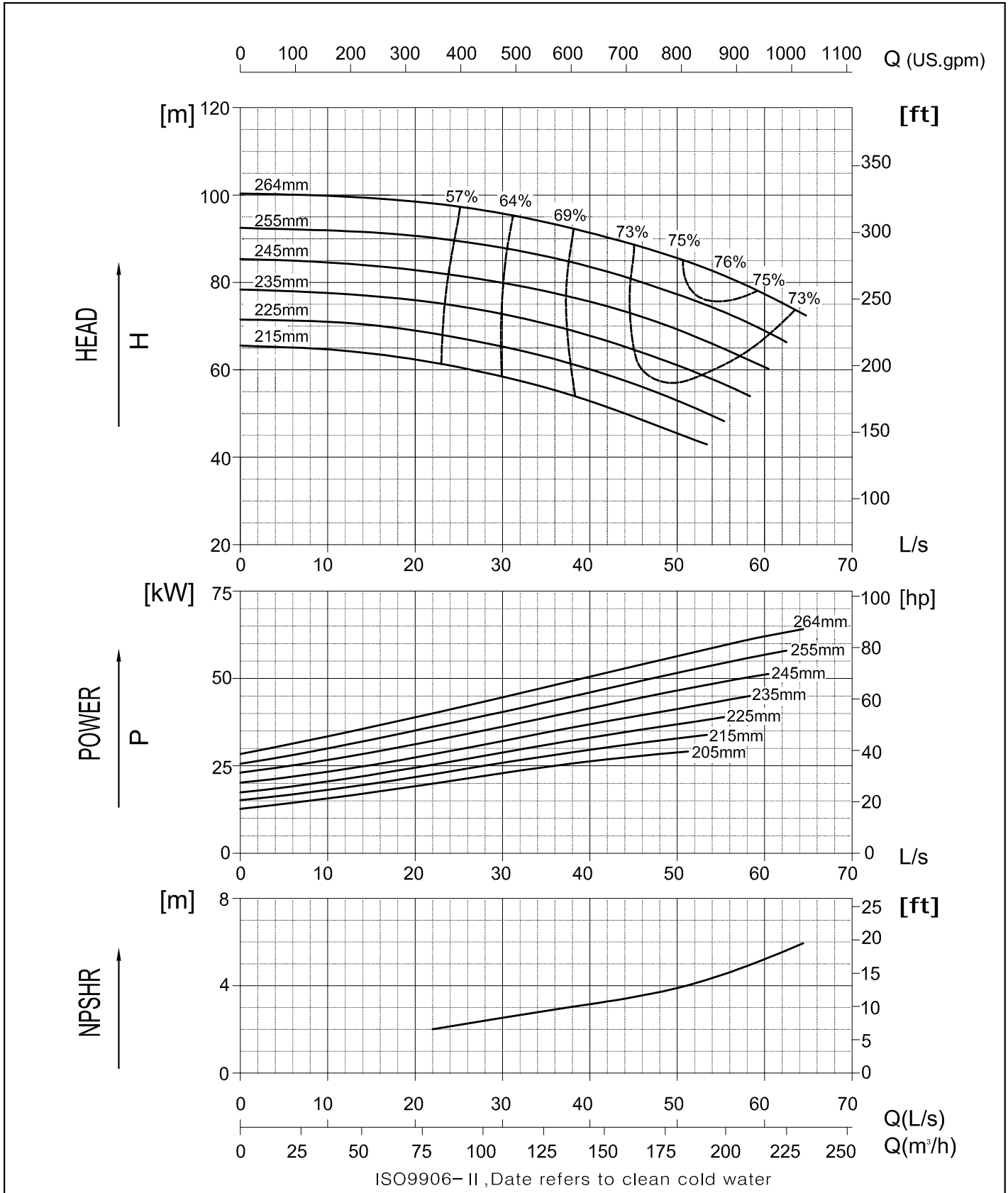

**NW80-320G**  
2900 RPM

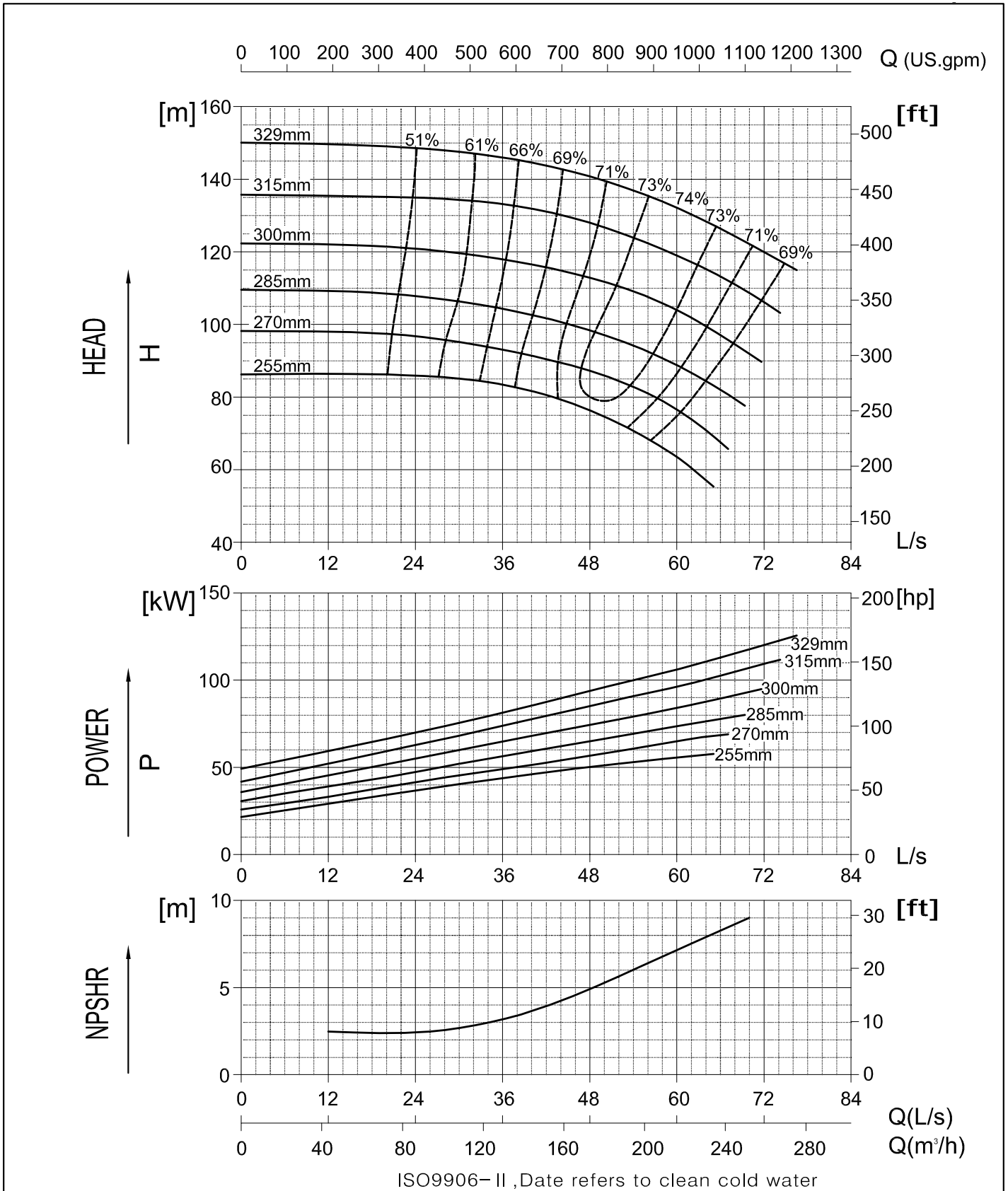

**NW100-160**  
2900 RPM

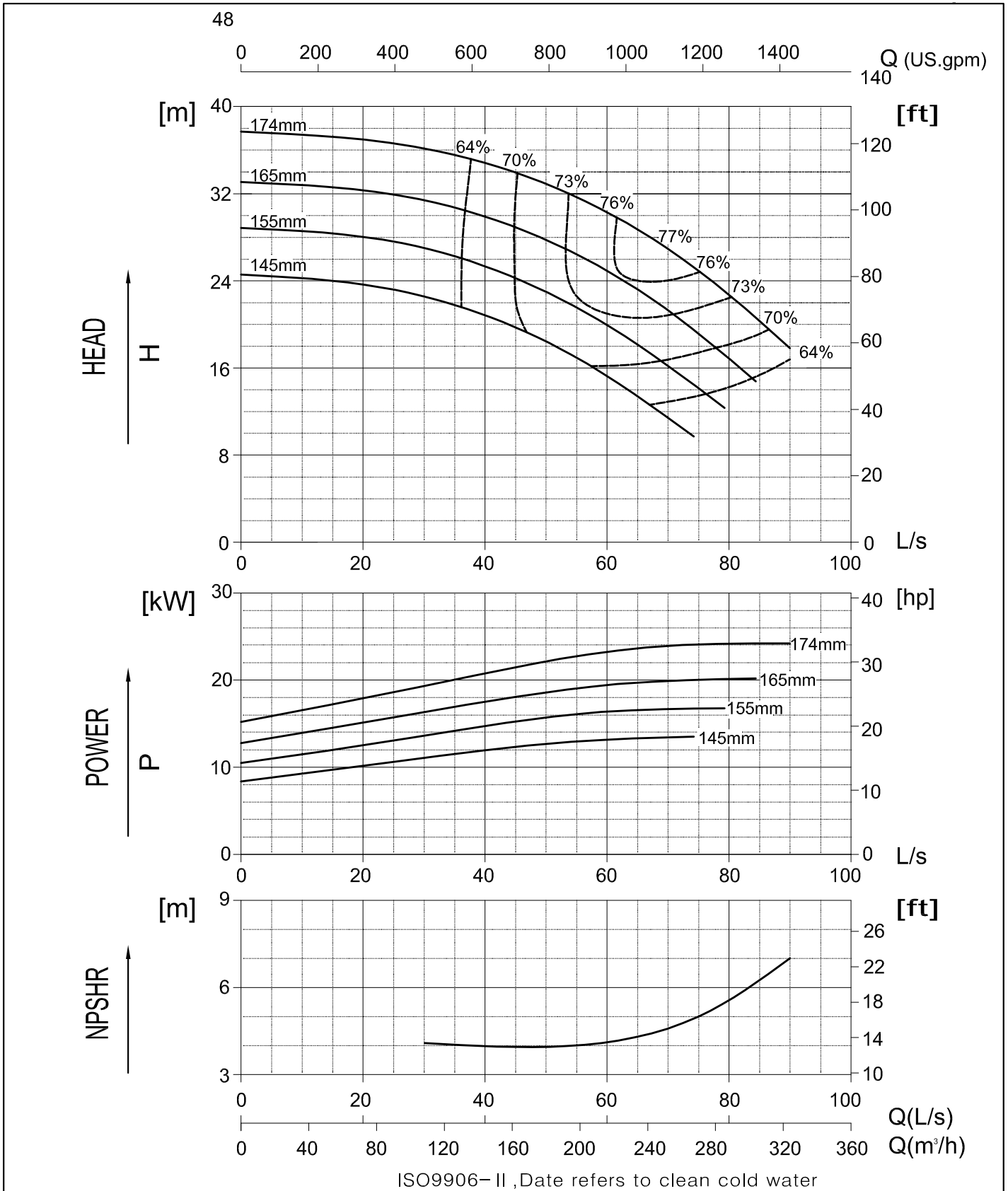

**NW100-200**  
2900 RPM

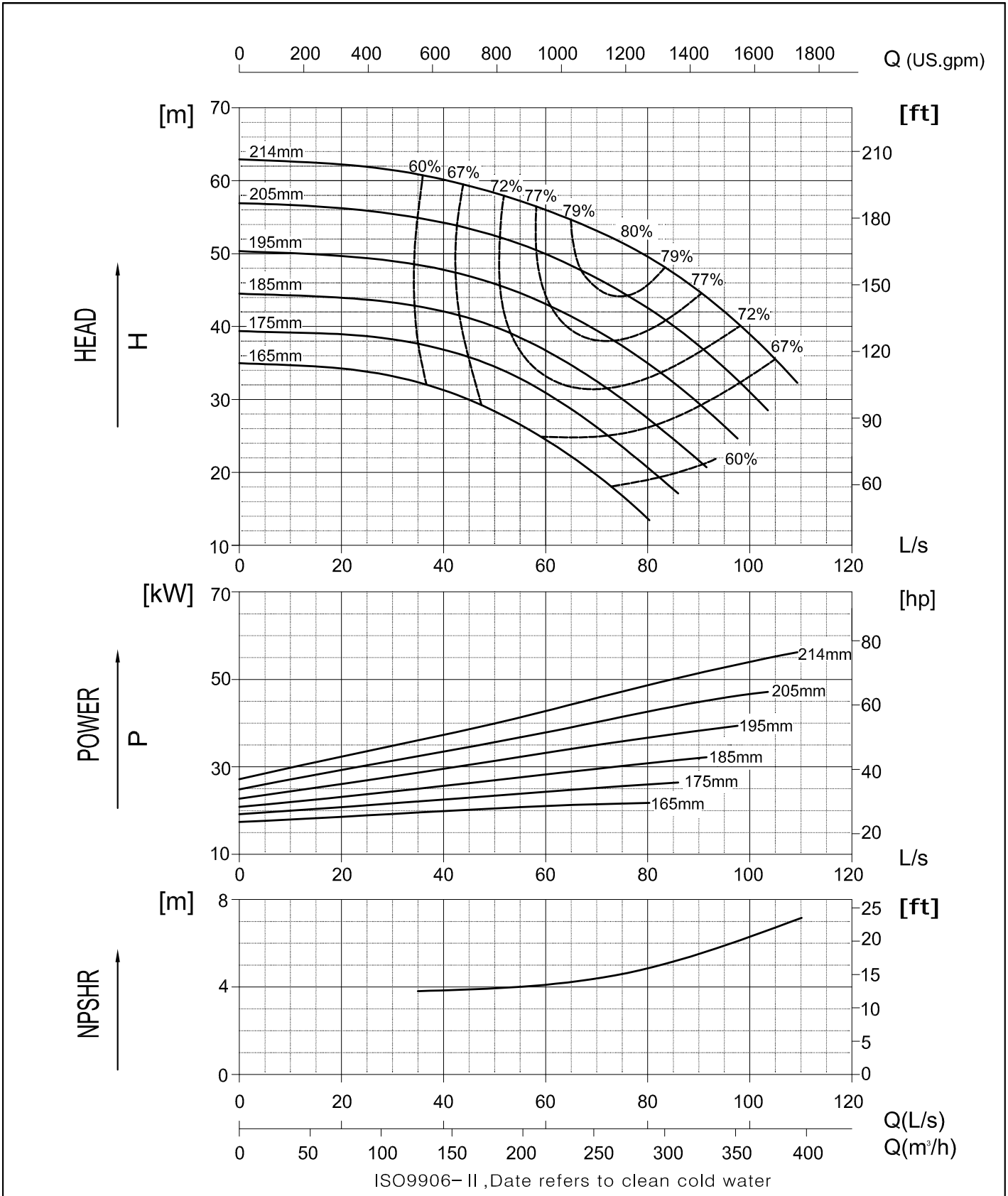

**NW100-250G**  
2900 RPM

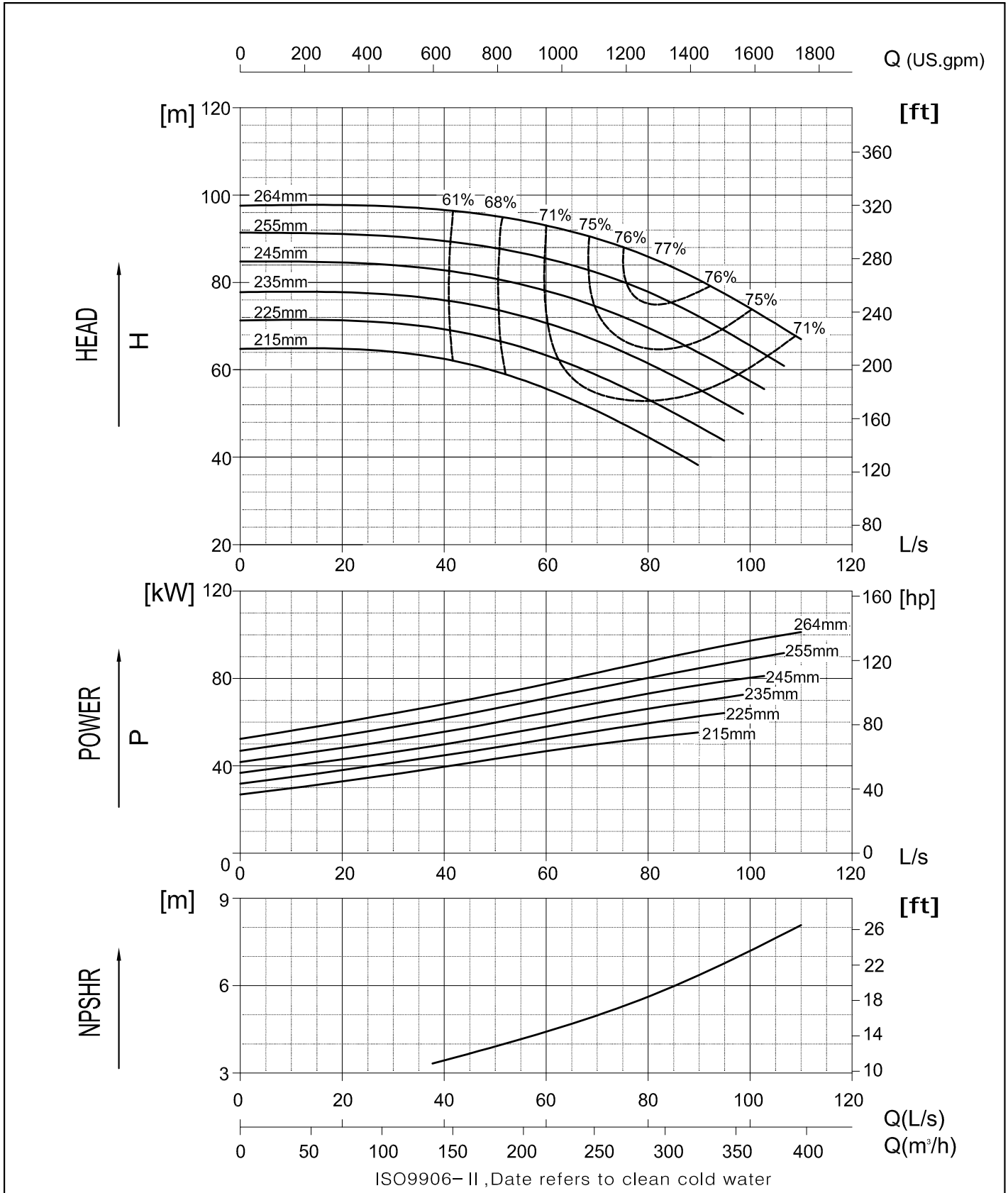

# NW100-315G

2900 RPM

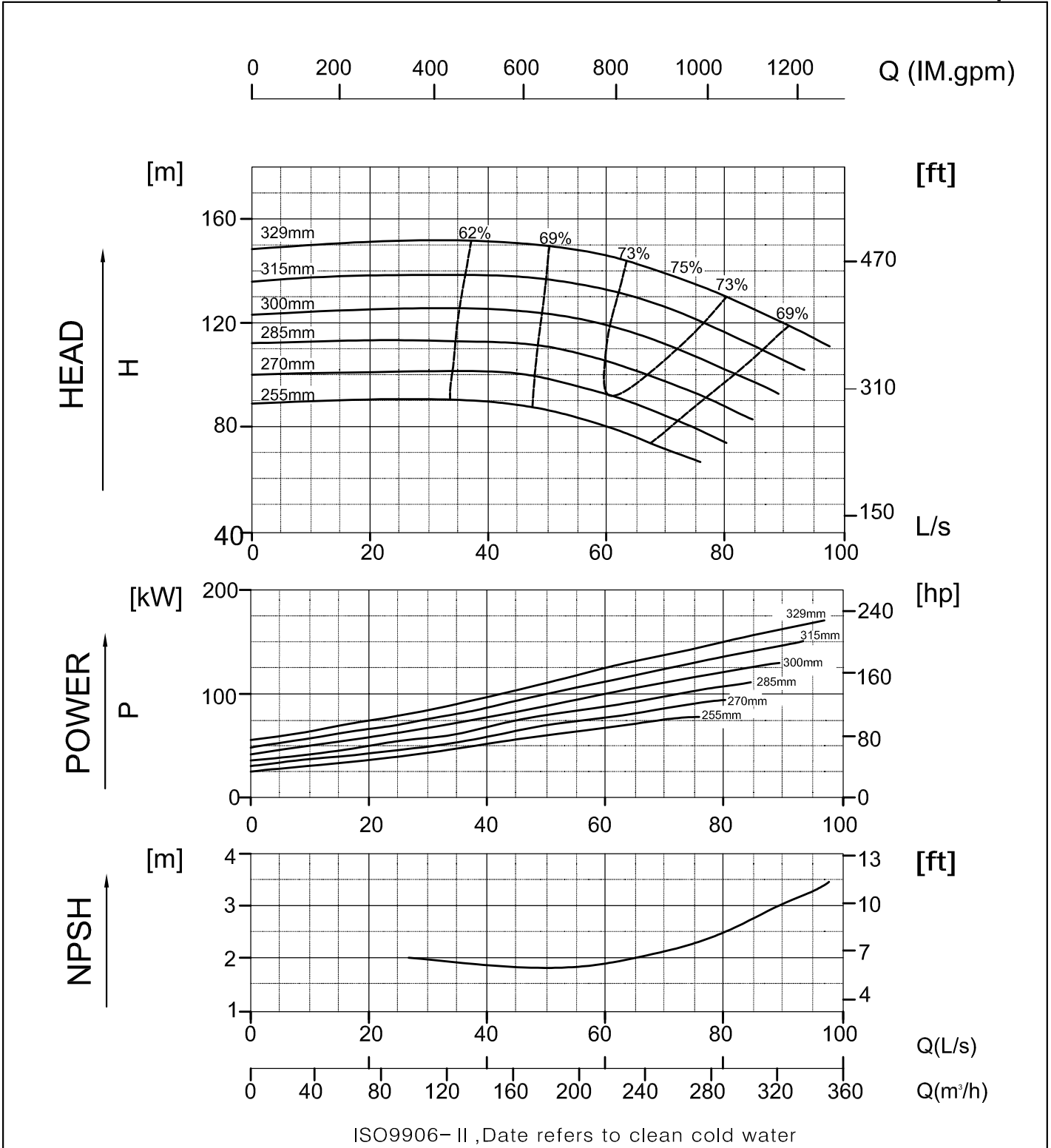

**NW125-200**  
2900 RPM

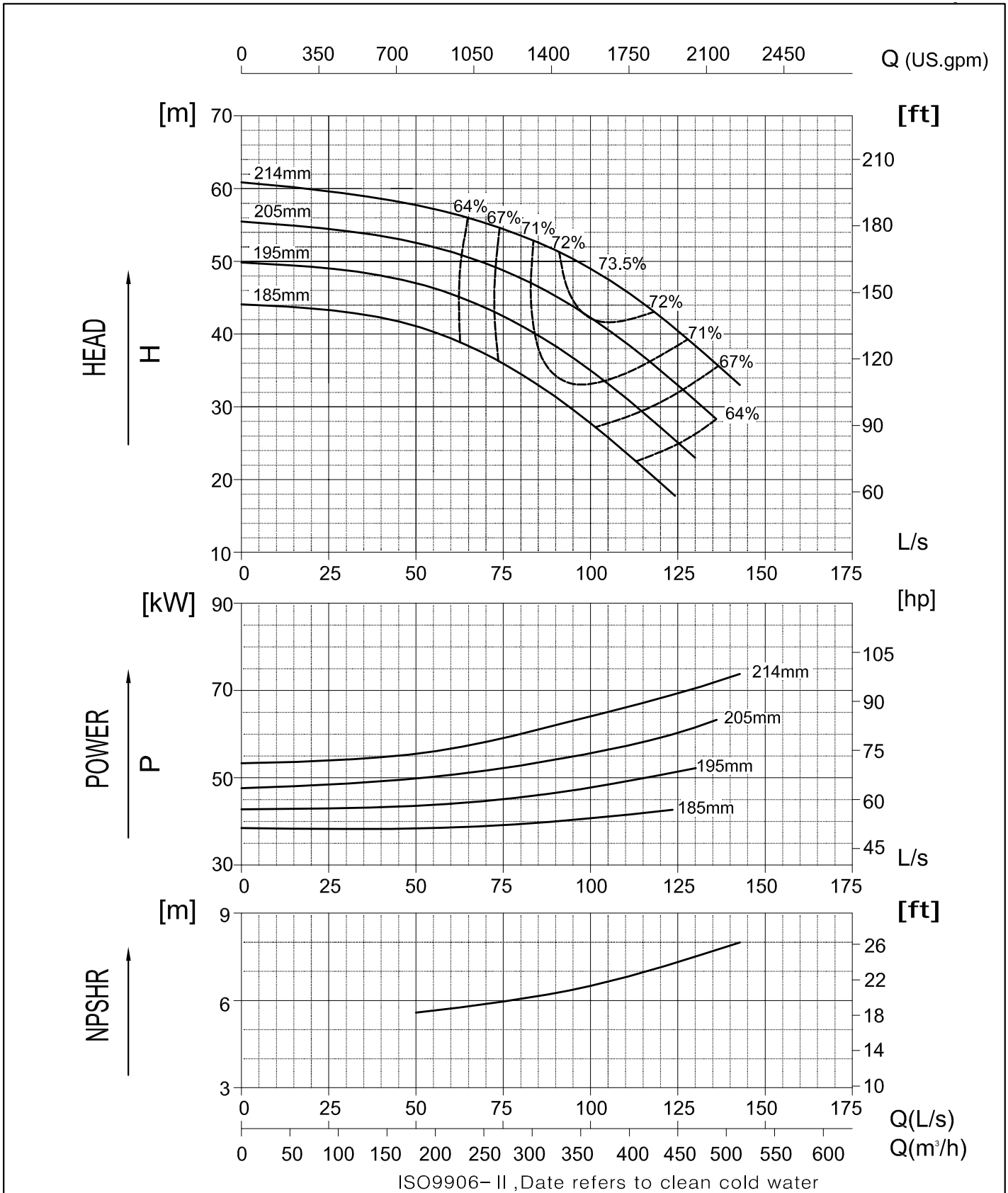

# NW125-250G

2900 RPM

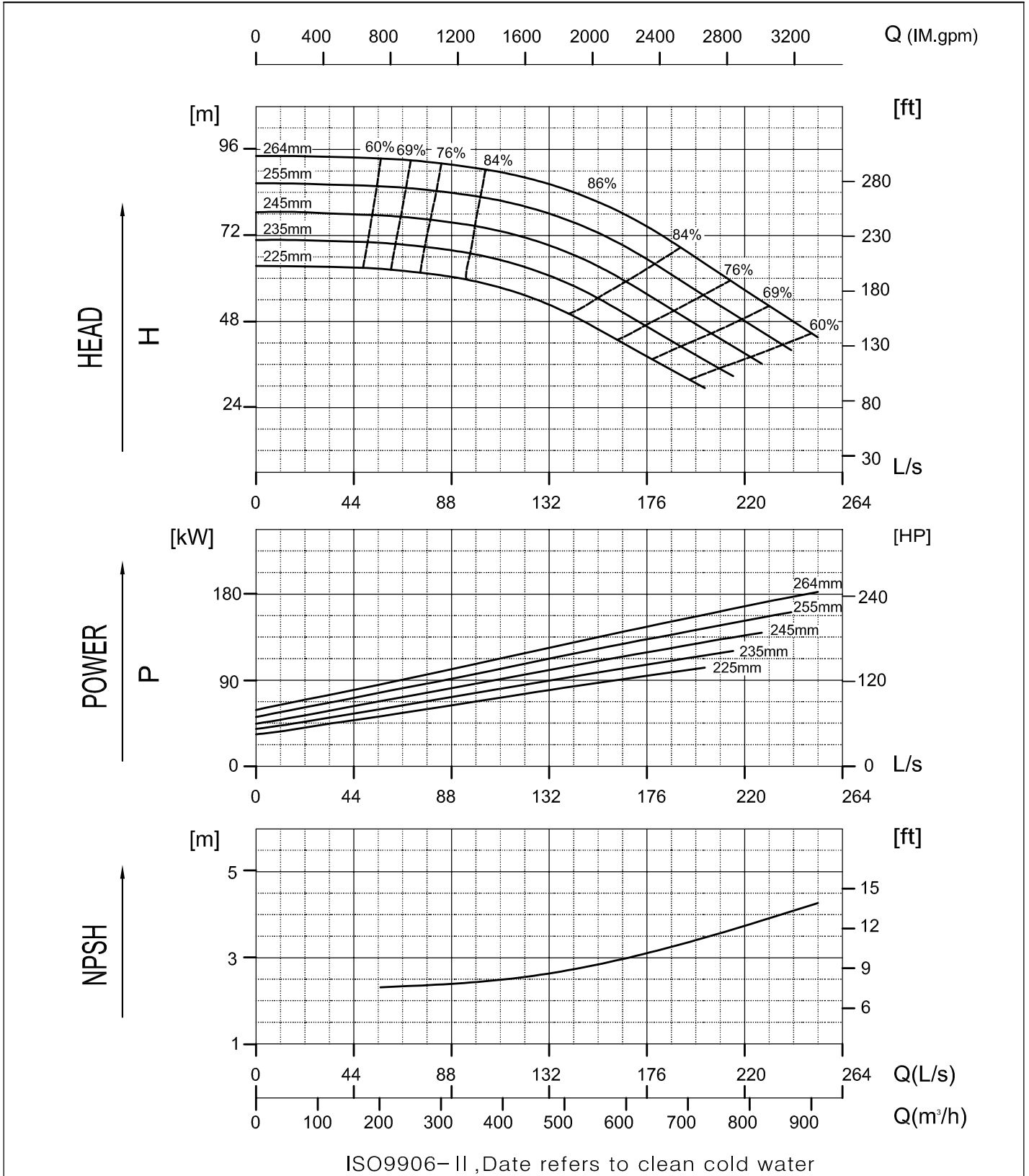

# Proindecsa

C/ Paraguay, parc. 13-5/6  
Polígono industrial Oeste  
30820 Alcantarilla, Murcia (Spain)

Tel. : +34 968 880 852  
proindecsa@proindecsa.com

[www.proindecsa.com](http://www.proindecsa.com)



🇪🇺 Proindecsa S.L. no se hace responsable de los posibles errores u omisiones que pueda contener este catálogo, ni de los daños o perjuicios que puedan derivarse de su uso. Proindecsa S.L. se reserva el derecho de modificar o actualizar el contenido de este catálogo en cualquier momento y sin previo aviso.

✳️ Proindecsa S.L. shall not be liable for any errors or omissions that this catalogue may contain, nor for any damages that may arise from its use. Proindecsa S.L. reserves the right to modify or update the contents of this catalogue at any time and without prior notice.

