

PYD

ELECTROBOMBAS

CATÁLOGO TARIFA

2025



www.proindecsa.com



V:W060111025



EL SUMINISTRO
COMPLETO DE BOMBEO

Proindecsa

¿Todavía no eres cliente de PYD?

Si eres **autónomo o empresa** y deseas acceder a un suministro integral de soluciones de bombeo, te invitamos a completar el **formulario de registro** que encontrarás en el reverso de esta página.

Una vez cumplimentado, puedes enviarlo a info@proindecsa.com o entregarlo directamente al **comercial que haya gestionado la visita**.

Únete a nuestra red de clientes y comienza a disfrutar de un **servicio profesional, eficiente y completo**, con la confianza de una empresa especializada en tecnología y soluciones para bombeo.



¡Únete a nuestra comunidad de clientes y
accede a los mejores descuentos de nuestro
catálogo!

INFORMACIÓN DEL CLIENTE

Denominación social : _____

NIF/CIF : _____

Actividad : _____

Dirección fiscal : _____

Dirección de entrega : _____

Población : _____ Provincia : _____ CP : _____

Teléfono : _____ Email : _____

Web : _____

PERSONA DE CONTACTO

Nombre	Departamento	Email	Teléfono / Ext.

DATOS DE FACTURACIÓN

IBAN : _____

Método de pago* : Giro

SWIFT : _____

Pagaré

Transferencia anticipada

CONTACTO

PROINDECSA, S.L., CIF: B-30030324

 C/Paraguay nº 13, parc. 5-6

Pol. Industrial Oeste, 30820 Alcantarilla
Murcia (SPAIN)

 (+34) 968 880 852

 proindecsa@proindecsa.com

 www.proindecsa.com

*Las operaciones están sujetas a una evaluación de riesgos y los métodos de pago aceptados se derterminarán de acuerdo con la valoración correspondiente.

Firma y sello cliente :

Por favor, envíe este formulario cumplimentado a info@proindecsa.com





Fundada en 1975 en Proindecsa siempre hemos estado vinculados al mundo de la bomba, especializándonos en el manejo de fluidos destinados a presurización para viviendas, sistemas de presión contra incendios, riego, industria, etc. Nuestra actividad es otorgar soluciones integrales de bombeo, con la inquietud de seguir mejorando nuestros servicios y ofreciendo siempre un producto a la altura de las exigencias de nuestros clientes

Nuestros valores están orientados hacia el respeto, compromiso, confianza y motivación, con una orientación clara hacia el Cliente y a la consecución de resultados. Trabajamos en equipo con dinamismo, iniciativa y creatividad.

Nuestras instalaciones, con más de 5.000m² repartidos en un total de dos naves industriales, con un centro de almacenamiento principal, situado en la ciudad del transporte, nos permiten dar una respuesta inmediata en la mayoría de nuestros productos con una única finalidad; conseguir dar siempre el mejor servicio posible. A ello se une nuestra extensa red de ventas y servicios técnicos presentes en toda la península, Baleares y en Canarias.



entidad asociada a
cepreven





ÍNDICE

Hidráulicas INOX 4"
Serie ST

18



Hidráulicas INOX 4" 6" 8" 10"
Serie SP

21



Semiaxiales INOX 6" 8" 10" 12"
Serie IX

32



Hidráulicas 4" 6"
Belardi

43



Motores sumergibles
4" 6" 8" 10"

48



Grupos
bombeo solar

55



Cuadro Solar
Serie PYDSOLAR

63



Variador de frecuencia
PYD

68



Bombas solares
Horizontales

69



Paneles solares
fotovoltaicos

70



Accesorios para
pozo

72



Cuadros eléctricos

73



Tubería
UPVC

76



Compacta para pozo 4"
Serie ONK

80



Compacta para pozo 4"
Serie ACUASUB

80



Compacta para pozo 5"
Serie SUB y AQUAPLUS

81



Compacta para pozo 6"
Serie 6SUB

82



Kit para pozo 4"
Serie SUBKIT

83



Achique
Serie AQUALITE

86



Achique
Serie HIPPO V

87



Achique
Serie HIPPO MAX

87



Achique
Serie LKS

88



Achique
Serie XKS-P/PW

88



Achique
Serie AQUASMART

89



Achique INOX
Serie SEA-GS INOX

90



Achique INOX
Serie XKS-S/SW

91



Achique INOX
Serie LION

91



Achique INOX
Serie TIGER INOX

92



Achique INOX
Serie BETTER

93



Achique INOX
Serie PANTHER

95



Achique
Serie V

96



Achique
Serie DUMPER

98



Achique
Serie TIGER

98



Achique
Serie TIGER MAX

99



Achique
Serie WQ y U

100



Achique
Serie SEMISON

101



ÍNDICE

Trituradora
Serie TR

102



Trituradora
Serie DTRT

102



Trituradora
Serie TRITON

103



Achique
Serie DM/DM4

104



Achique
Serie DV/DV4

105



Cuadros
ALL-IN-ONE

106



Cuadro
aguas residuales

107



Zócalo/pie de
acoplamiento

107



Estación aguas residuales
Serie AQUATANK

108



Estación aguas residuales
Serie TANKPLUS

109



Achique
Serie KS

110



Achique
Serie KBZ

111



Achique
Serie NTZ

112



Achique
Serie KBS

112



Achique
Serie CANTER

113



Motobombas
Serie ENG

116



Aguas
cargadas

120



12-24V

122



Autocebantes
manuales

124



Autoaspirantes
12-24V

125



Volumétrica
Serie MD

126



Arrastre magnético
Serie PD

128



Soplantes
Serie BLOW

130



Dosificadora
Serie Kompact

132



Dosificadora
Serie BA

132



Dosificadoras pistón
Series AP/BP

133



Agitadores en
acero INOX

134



Depósitos de
polietileno

134



Bombas de
fuente

136



Accesorios para
fuente y acuarios

138



Piscina
Serie POOL y POOL2

140



Piscina grandes dimensiones
Serie SCA INOX

142



Piscina grandes dimensiones
Serie CMP

143



Cuadros para iluminación
y protección de piscina

144



Periférica
Serie PH

146



Centrífuga INOX
Serie INOX-100

146



ÍNDICE

Centrífuga
Serie JET-C

147



Centrífuga multicelular
Serie JET-L

147



Centrífuga multicelular
Serie MP

148



Centrífuga multicelular
Serie SBM

148



Centrífuga multicelular
Serie HMP

149



Centrífuga multicelular
Serie SH

150



Centrífuga multicelular
Serie ULTRA

152



Centrífuga biturbina
Serie CB

154



Centrífuga biturbina
Serie CBP

154



Multicelular vertical
Serie ULTRA

156



Multicelular vertical
Serie VERTI-P

158



Multicelular
Serie VERTI-I

160



Multicelular vertical
Serie CTV

161



Multicelular vertical
Serie VERTINOX

162



Centrífuga vertical
Serie MSV

168



Centrífuga horizontal
Serie CD

170



Centrífuga horizontal
Serie CRP

170



Centrífuga horizontal
Series CH y CHP

171



Centrífuga horizontal
Serie BP

172



Centrífuga horizontal
Serie CSP

172



Gran caudal
Serie CST

173



Aspiración profunda
Serie PDP

173



Centrífuga INOX
Serie PWK

176



Centrífuga INOX
Serie PWB

176



Centrífuga INOX
Serie PDC

177



Centrífuga INOX
Serie 2PDC

178



Normalizada monobloc
Serie NM

180



Normalizada monobloc
Serie CM

182



Normalizada INOX
Serie CX

184



Normalizada eje libre
Serie NW

188



Centrífuga eje libre
Serie CBS

189



Cámara partida
Serie BCP

190



Motor eléctrico
B3

192



Circuladora
Serie PC

194



Circuladora
Serie PCB

195



Circuladora
Serie PCV

195



ÍNDICE

Depósito EPDM
Serie DEP

198



Depósito butilo
Membrana fija

198



Depósito butilo
Serie HYB

199



Depósitos galvanizados
Serie GALV

200



Valvulería

202



Controlador
Serie CONTROLPUMP

207



Controlador
Serie ECO

207



Controlador
Serie PYD-5

208



Controlador
Serie PYD-15

209



Controlador
Serie DIGI-PLUS

210



Controlador
Serie EURO-2

211



Controlador
Serie OPTIPLUS

211



Presostato electrónico
Serie SWITCHMATIC

212



Presostato electrónico
Serie SWITCHMATIC 2T

212



Presostato electrónico
Serie T-KIT SWITCHMATIC

214



Variador
Serie W713B

216



Variador
Serie WLD191

218



Variador
Serie SPEEDMATIC EASY

220



Variador
Serie SPEEDBOX

220



Variador
Serie SPEEDBOX DUO

221



Variador
Serie SPEEDBOX DUO SET

221



Cuadro de protección
Serie VSC

222



Cuadro de
protección

226



Cuadro de
alternancia

226



Sistema de protección
Serie SAFEMATIC

227



Presostatos de
arranque

227



Accesorios

227



Grupos de
presión

232



Grupo de
trasiego gasóleo

242



Grupos contra
incendios

244



Sanitarias

252



GVR
POMPE

258



Neumáticas
Doble diafragma

266



SCHMITT

272



**SACEMI
GAMAR**

277



Condiciones generales
y certificados

302





Solicita nuestros catálogos técnicos en formato físico y descubre nuestra gama de productos con todas sus especificaciones.

Contáctanos para recibirlos.



www.proindecsa.com





HIDRÁULICAS SUMERGIBLES PARA POZO



HIDRÁULICAS INOX 4" SERIE ST

DESCRIPCIÓN

- Electrobombas sumergibles multicelulares de turbina flotante de 4" para pozos, acoplable a motores sumergibles tipo **NEMA** de gran rendimiento.
- La construcción con turbina flotante y **difusores reforzados con acero inoxidable**, aporta una alta admisión y resistencia a la abrasión por arenas. Además cuenta con **rodamientos de alta calidad** y un eje hexagonal que aseguran un correcto desarrollo de los impulsores y una **mayor vida útil**.



MATERIALES

- Cuerpo de aspiración e impulsión: **Acero INOX 304**
- Válvula de retención: **Acero INOX 304**
- Camisa: **Acero INOX 304**
- Eje: **Acero INOX 304**
- Impulsores: **Noryl**
- Difusores: **Noryl reforzado con acero inoxidable**

ÁREA DE TRABAJO

- Caudal máx.: **24 m³/h**
- Altura máx.: **325 mca**
- Rango de Potencia: **0,37 - 7,50 kW**
- Agua química y mecánicamente: **No agresiva**
- Contenido en sólido: **< 50 g/m³**
- Temperatura máx.: **Supeditada a tº máx. del motor.**



4ST1

MODELO	L	Peso	DN	P ₂	
	mm	Kg	Ø"	kW	Hp
4ST1/10	332	3,2	1¼	0,37	0,5
4ST1/13	382	3,7	1¼	0,37	0,5
4ST1/19	481	4,7	1¼	0,55	0,75
4ST1/26	596	5,8	1¼	0,75	1,0
4ST1/38	832	8,1	1¼	1,1	1,5
4ST1/49	1.052	10,5	1¼	1,5	2,0

CAUDAL							P.V.P. B C. BOMBA
m³/h	0	0,3	0,6	0,9	1,2	1,5	
l/min	0	5	10	15	20	25	
ALTURA DE CARGA EN METROS							
	67	63	55	46	33	18	135,00
	86	78	70	56	42	23	140,00
	126	110	105	86	60	30	180,00
	173	160	141	117	81	39	216,00
	253	234	208	169	117	52	333,00
	325	303	268	219	151	68	396,00

4ST2

MODELO	L	Peso	DN	P ₂	
	mm	Kg	Ø"	kW	Hp
4ST2/5	257	2,4	1¼	0,37	0,5
4ST2/7	293	2,7	1¼	0,37	0,5
4ST2/10	347	3,3	1¼	0,55	0,75
4ST2/14	419	4,0	1¼	0,75	1,0
4ST2/20	527	5,0	1¼	1,1	1,5
4ST2/28	671	6,4	1¼	1,5	2,0
4ST2/40	963	9,4	1¼	2,2	3,0

CAUDAL										P.V.P. B C. BOMBA
m³/h	0	0,9	1,2	1,5	1,8	2,1	2,4	2,7	3	
l/min	0	15	20	25	30	35	40	45	50	
ALTURA DE CARGA EN METROS										
	34	32	31	29	27	25	23	19	16	113,00
	46	43	42	39	36	33	29	26	22	124,00
	67	64	61	58	54	49	43	36	28	146,00
	92	86	83	79	74	67	60	52	42	171,00
	139	131	127	120	111	101	90	75	60	207,00
	180	170	164	154	144	131	115	97	78	266,00
	260	243	230	215	198	178	154	137	96	362,00

4ST2.5

MODELO	L	Peso	DN	P ₂	
	mm	Kg	Ø"	kW	Hp
4ST2.5/5	265	2,4	1¼	0,37	0,5
4ST2.5/8	323	2,9	1¼	0,55	0,75
4ST2.5/11	382	3,4	1¼	0,75	1,0
4ST2.5/16	479	4,3	1¼	1,1	1,5
4ST2.5/21	577	5,2	1¼	1,5	2,0
4ST2.5/32	829	7,4	1¼	2,2	3,0
4ST2.5/42	1.059	9,4	1¼	3,0	4,0

CAUDAL											P.V.P. B C. BOMBA
m³/h	0	1,2	1,5	1,8	2,1	2,4	2,7	3	3,6	4,2	
l/min	0	20	25	30	35	40	45	50	60	70	
ALTURA DE CARGA EN METROS											
	34	32	31	30	29	27	25	23	18	11	113,00
	54	51	50	49	46	43	41	38	30	19	128,00
	72	68	66	64	61	58	54	49	38	26	149,00
	106	101	98	95	89	83	77	70	54	33	176,00
	142	135	132	127	122	115	106	100	79	49	209,00
	208	200	194	187	177	165	152	138	104	62	293,00
	285	268	263	252	242	228	210	197	155	95	369,00

4ST3

MODELO	L mm	Peso Kg	DN Ø"	P ₂		CAUDAL											P.V.P. C. BOMBA	
				kW	Hp	m ³ /h	l/min	0	1,5	1,8	2,1	2,4	2,7	3	3,6	4,2		4,8
4ST3/5	275	2,5	1½	0,37	0,5	33	29	28	27	26	25	24	21	18	13	8	3	119,00
4ST3/7	318	2,8	1½	0,55	0,75	46	43	42	41	39	38	36	33	28	22	15	7	131,00
4ST3/9	361	3,2	1½	0,75	1,0	59	55	54	52	51	49	47	43	37	28	20	10	146,00
4ST3/14	468	4,2	1½	1,1	1,5	93	87	86	83	81	79	76	68	58	47	33	20	180,00
4ST3/18	554	4,9	1½	1,5	2,0	120	113	111	108	105	102	98	88	75	60	42	25	203,00
4ST3/27	786	6,9	1½	2,2	3,0	175	164	161	157	152	147	141	127	109	87	61	35	270,00
4ST3/35	996	9,1	1½	3,0	4,0	228	212	208	203	197	191	184	166	145	119	85	46	367,00
4ST3/48	1.275	11,5	1½	4,0	5,5	309	289	283	276	267	258	248	225	197	162	120	73	455,00

4ST4

MODELO	L mm	Peso Kg	DN Ø"	P ₂		CAUDAL											P.V.P. C. BOMBA	
				kW	Hp	m ³ /h	l/min	0	2,1	2,4	2,7	3	3,6	4,2	4,8	5,4		6
4ST4/4	267	2,4	1½	0,37	0,5	26	23	22	22	21	19	17	14	11	7			113,00
4ST4/6	317	2,8	1½	0,55	0,75	38	36	35	33	32	30	26	22	18	12			128,00
4ST4/8	367	3,2	1½	0,75	1,0	51	47	46	44	43	39	35	30	24	18			142,00
4ST4/12	467	4,1	1½	1,1	1,5	77	72	71	69	68	63	57	49	41	31			176,00
4ST4/16	567	4,9	1½	1,5	2,0	102	98	96	94	92	86	77	68	57	46			203,00
4ST4/24	805	7,0	1½	2,2	3,0	151	142	139	136	132	122	111	97	80	62			270,00
4ST4/32	1.043	9,3	1½	3,0	4,0	203	188	185	180	175	162	146	127	105	80			362,00
4ST4/44	1.343	11,9	1½	4,0	5,5	278	265	260	254	247	230	210	187	159	127			473,00

4ST6

MODELO	L mm	Peso Kg	DN Ø"	P ₂		CAUDAL											P.V.P. C. BOMBA	
				kW	Hp	m ³ /h	l/min	0	3	3,6	4,2	4,8	5,4	6	7,2	8,4		
4ST6/7	395	3,4	2	0,75	1,0	42	36	34	32	30	28	25	19	11				140,00
4ST6/10	488	4,3	2	1,1	1,5	62	53	51	48	45	41	38	29	18				171,00
4ST6/14	612	5,2	2	1,5	2,0	90	77	74	71	68	63	59	46	28				212,00
4ST6/20	836	7,1	2	2,2	3,0	125	107	102	97	92	86	80	62	40				261,00
4ST6/27	1.053	8,9	2	3,0	4,0	169	145	139	131	123	115	107	84	55				313,00
4ST6/36	1.370	11,8	2	4,0	5,5	221	190	181	173	164	154	143	112	72				450,00
4ST6/49	1.849	15,7	2	5,5	7,5	302	257	246	234	222	209	193	151	96				579,00

4ST8

MODELO	L mm	Peso Kg	DN Ø"	P ₂		CAUDAL											P.V.P. C. BOMBA	
				kW	Hp	m ³ /h	l/min	0	4,8	5,4	6	7,2	8,4	9,6	10,8	12		
4ST8/4	302	2,6	2	0,75	1,0	26	23	22	21	20	18	16	12	9				119,00
4ST8/6	364	3,2	2	1,1	1,5	38	35	34	33	31	28	24	19	14				140,00
4ST8/8	426	3,7	2	1,5	2,0	52	47	45	44	41	37	31	25	18				153,00
4ST8/13	581	5,0	2	2,2	3,0	82	75	73	71	66	59	50	40	30				198,00
4ST8/17	743	6,3	2	3,0	4,0	108	98	96	94	87	79	70	58	46				241,00
4ST8/23	929	7,9	2	4,0	5,5	148	134	131	127	118	108	95	79	60				293,00
4ST8/32	1.246	10,7	2	5,5	7,5	202	182	178	172	160	143	125	105	80				414,00

4ST9

MODELO	L mm	Peso Kg	DN Ø"	P ₂		CAUDAL											P.V.P. C. BOMBA											
						ALTURA DE CARGA EN METROS																						
						0	4,8	5,4	6	7,2	8,4	9,6	10,8	12	13,2	14,4												
4ST9/7	490	4,2	2	1,1	1,5	0	80	90	100	120	140	160	180	200	220	240	41	35	34	33	32	29	26	23	18	14	8	176,00
4ST9/10	623	5,3	2	1,5	2,0	0	80	90	100	120	140	160	180	200	220	240	58	49	48	47	44	41	37	32	27	20	13	221,00
4ST9/14	839	7,0	2	2,2	3,0	0	80	90	100	120	140	160	180	200	220	240	83	71	69	67	63	58	54	48	40	31	20	270,00
4ST9/18	1.017	8,5	2	3,0	4,0	0	80	90	100	120	140	160	180	200	220	240	107	92	90	87	83	77	70	62	52	39	26	317,00
4ST9/24	1.284	10,7	2	4,0	5,5	0	80	90	100	120	140	160	180	200	220	240	141	118	116	113	106	97	88	77	63	49	33	410,00
4ST9/32	1.754	14,7	2	5,5	7,5	0	80	90	100	120	140	160	180	200	220	240	189	162	157	153	144	134	122	107	90	70	47	570,00
4ST9/44	1.817	18,0	2	7,5	10	0	80	90	100	120	140	160	180	200	220	240	254	222	216	210	197	183	166	156	133	96	60	711,00

4ST12

MODELO	L mm	Peso Kg	DN Ø"	P ₂		CAUDAL											P.V.P. C. BOMBA									
						ALTURA DE CARGA EN METROS																				
						0	6	7,2	8,4	9,6	10,8	12	13,2	14,4	15,6											
4ST12/7	542	4,5	2	1,5	2,0	0	100	120	140	160	180	200	220	240	260	45	37	36	33	31	28	25	22	18	14	180,00
4ST12/10	698	5,8	2	2,2	3,0	0	100	120	140	160	180	200	220	240	260	64	54	52	48	44	41	36	32	26	20	216,00
4ST12/14	944	7,8	2	3,0	4,0	0	100	120	140	160	180	200	220	240	260	89	76	72	67	62	56	49	43	35	28	279,00
4ST12/19	1.204	9,9	2	4,0	5,5	0	100	120	140	160	180	200	220	240	260	120	102	97	91	89	76	68	58	48	37	329,00
4ST12/26	1.682	13,9	2	5,5	7,5	0	100	120	140	160	180	200	220	240	260	163	136	129	120	111	100	87	75	61	48	504,00
4ST12/34	2.098	17,9	2	7,5	10	0	100	120	140	160	180	200	220	240	260	215	180	170	157	144	136	110	93	77	60	599,00

4ST15

MODELO	L mm	Peso Kg	DN Ø"	P ₂		CAUDAL										P.V.P. C. BOMBA										
						ALTURA DE CARGA EN METROS																				
						0	9,6	12	13,2	14,4	15,6	18	19,2	21,6	24											
4ST15/8	680	5,7	2	2,2	3,0	0	160	200	220	240	260	300	320	360	400	49	38	34	32	30	28	23	20	15	9	212,00
4ST15/11	883	7,2	2	3,0	4,0	0	160	200	220	240	260	300	320	360	400	67	53	48	45	42	39	33	30	23	16	261,00
4ST15/15	1.153	9,3	2	4,0	5,5	0	160	200	220	240	260	300	320	360	400	93	73	66	62	59	55	47	43	34	25	324,00
4ST15/20	1.528	12,6	2	5,5	7,5	0	160	200	220	240	260	300	320	360	400	122	95	86	81	76	72	61	56	44	32	455,00
4ST15/28	2.068	16,7	2	7,5	10	0	160	200	220	240	260	300	320	360	400	165	128	115	108	103	95	80	73	55	40	581,00

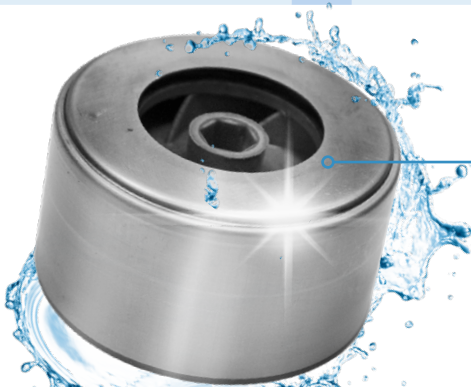

DIFUSORES REFORZADOS EN
ACERO INOX 304

DESCRIPCIÓN

- Electrobombas sumergibles multicelulares completamente en INOX de 4" para pozos, acoplable a motores sumergibles tipo **NEMA**.
- Está construida por completo en acero inoxidable, de forma que cuenta con una **alta rigidez y resistencia a la corrosión** y con altos niveles de rendimiento.

MATERIALES

- Cuerpo de aspiración e impulsión: **Acero INOX 304**
- Válvula de retención: **Acero INOX 304**
- Eje: **Acero INOX 304**
- Impulsores: **Acero INOX 304**
- Difusores: **Acero INOX 304**

ÁREA DE TRABAJO

- Caudal máx.: **18 m³/h**
- Altura máx.: **377 mca**
- Rango de Potencia: **0,37 - 7,50 kW**
- Agua química y mecánicamente: **No agresiva**
- Contenido en sólido: **< 50 g/m³**
- Temperatura máx.: **Supeditada a t° máx. del motor.**



DISPONIBLE EN
50Hz Y 60Hz

4SP1						CAUDAL																
MODELO	L mm	Peso Kg	DN Ø"	P ₂																		
				kW	Hp	m ³ /h	0,3	0,4	0,6	0,8	1	1,2	1,4	1,5	2,1	l/min	5	6,6	10	13,3	16,6	20
4SP1-09	337	3,1	1 1/4	0,37	0,5	50	48	45	42	34	31	29	28	25	156,00							
4SP1-14	442	4,1	1 1/4	0,37	0,5	75	72	66	62	50	46	42	41	39	202,00							
4SP1-18	526	4,7	1 1/4	0,55	0,75	84	82	81	78	75	71	65	64	50	238,00							
4SP1-21	589	5,2	1 1/4	0,55	0,75	113	105	98	87	76	64	61	60	58	266,00							
4SP1-28	736	6,6	1 1/4	0,75	1,0	154	143	132	116	102	83	81	80	78	359,00							
4SP1-36	904	8,6	1 1/4	1,1	1,50	193	181	168	153	117	112	109	105	100	568,00							

4SP2						CAUDAL												
MODELO	L mm	Peso Kg	DN Ø"	P ₂														
				kW	Hp	m ³ /h	0	1	1,4	1,8	2	2,4	2,8	l/min	0	17	23	30
4SP2-06	274	2,4	1 1/4	0,37	0,5	36	33	30	26	24	17	13	152,00					
4SP2-09	337	3,2	1 1/4	0,37	0,5	53	48	44	38	34	24	17	181,00					
4SP2-13	420	4,3	1 1/4	0,55	0,75	77	70	64	55	50	35	26	217,00					
4SP2-18	526	5,7	1 1/4	0,75	1,0	107	97	89	77	69	49	36	271,00					
4SP2-23	631	7,0	1 1/4	1,1	1,5	137	124	114	99	90	64	47	333,00					
4SP2-28	736	8,4	1 1/4	1,5	2,0	167	152	140	122	110	79	59	374,00					
4SP2-33	841	9,7	1 1/4	1,5	2,0	196	178	163	142	128	90	66	432,00					
4SP2-40	998	11,6	1 1/4	2,2	3,0	245	221	203	176	158	111	81	584,00					
4SP2-48	1.156	13,8	1 1/4	2,2	3,0	292	262	240	207	186	129	93	698,00					
4SP2-55	1.303	15,6	1 1/4	3,0	4,0	336	302	277	240	215	150	109	768,00					

HIDRÁULICAS INOX 4" SERIE SP



BOMBEO PARA POZO

4SP5 = QF5 = SP3						CAUDAL										P.V.P. C. BOMBA
MODELO	L mm	Peso Kg	DN Ø"	P ₂		ALTURA DE CARGA EN METROS										
				kW	Hp	0	1	1,4	1,8	2	2,4	2,8	3,4	4	4,4	
4SP5-06	274	2,4	1 ¼	0,37	0,5	38	35	34	32	31	30	27	22	15	12	144,00
4SP5-09	337	3,0	1 ¼	0,55	0,75	57	54	51	49	47	45	41	33	23	19	181,00
4SP5-12	400	3,7	1 ¼	0,75	1,0	76	70	68	65	64	60	55	45	31	26	210,00
4SP5-15	463	4,3	1 ¼	1,1	1,5	95	87	85	82	80	76	70	57	40	33	234,00
4SP5-18	526	4,9	1 ¼	1,1	1,5	113	105	101	97	95	89	82	67	46	38	259,00
4SP5-22	610	5,5	1 ¼	1,5	2,0	139	129	125	120	117	110	101	83	57	47	320,00
4SP5-25	673	6,4	1 ¼	1,5	2,0	157	145	140	135	131	124	113	92	63	52	345,00
4SP5-29	757	7,2	1 ¼	2,2	3,0	184	171	166	159	156	147	136	111	78	65	382,00
4SP5-33	841	8,0	1 ¼	2,2	3,0	209	194	187	180	176	166	152	125	87	72	436,00
4SP5-39	967	9,3	1 ¼	3,0	4,0	246	230	223	216	212	201	188	160	120	105	596,00
4SP5-45	1.093	10,6	1 ¼	3,0	4,0	283	264	255	247	242	229	214	181	135	118	698,00
4SP5-52	1.240	12,0	1 ¼	4,0	5,5	328	308	298	289	283	269	251	214	161	141	797,00
4SP5-58	1.366	13,3	1 ¼	4,0	5,5	348	315	302	288	280	268	260	238	197	160	827,00
4SP5-60	1.408	13,8	1 ¼	4,0	5,5	377	350	341	330	323	307	286	250	210	191	855,00

4SP6 = QF6 = SP5						CAUDAL											P.V.P. C. BOMBA		
MODELO	L mm	Peso Kg	DN Ø"	P ₂		ALTURA DE CARGA EN METROS													
				kW	Hp	0	1	1,4	1,8	2	2,4	2,8	3,4	4	4,4	5	6	6,7	
4SP6-04	232	2,2	1 ½	0,37	0,5	26	24	23	23	22	22	21	20	19	18	16	11	9	148,00
4SP6-06	274	2,7	1 ½	0,55	0,75	38	36	35	34	33	33	32	30	28	26	24	17	11	169,00
4SP6-08	316	3,3	1 ½	0,75	1,0	51	48	47	46	45	44	43	40	38	36	32	23	15	177,00
4SP6-12	400	4,4	1 ½	1,1	1,5	77	72	70	68	67	65	63	60	56	54	47	35	23	217,00
4SP6-17	505	5,8	1 ½	1,5	2,0	109	100	97	96	94	92	90	85	80	75	67	49	32	259,00
4SP6-21	589	6,9	1 ½	2,2	3,0	135	126	122	120	118	115	112	106	100	95	85	63	42	312,00
4SP6-25	673	8,0	1 ½	2,2	3,0	160	150	145	141	139	135	131	125	118	112	99	72	48	357,00
4SP6-33	841	10,3	1 ½	3,0	4,0	207	195	190	186	183	179	173	166	155	148	130	95	62	432,00
4SP6-38	946	11,7	1 ½	4,0	5,5	238	220	211	208	204	200	190	183	173	162	152	114	69	584,00
4SP6-40	1.028	12,3	1 ½	4,0	5,5	251	233	225	220	217	210	204	195	187	178	160	120	75	615,00
4SP6-44	1.072	13,3	1 ½	4,0	5,5	281	260	257	250	245	240	232	220	207	195	174	127	84	642,00
4SP6-52	1.292	15,6	1 ½	5,5	7,5	326	304	295	286	281	271	263	254	241	237	208	156	110	798,00
4SP6-60	1.468	17,9	1 ½	5,5	7,5	376	350	340	330	325	315	305	300	279	265	240	180	130	922,00

4SP8 = QF8 = SP6						CAUDAL								P.V.P. C. BOMBA	
MODELO	L mm	Peso Kg	DN Ø"	P ₂		ALTURA DE CARGA EN METROS									
				kW	Hp	0	1	2	3	4	5	6	7	8	
4SP8-05	258	2,8	1 ½	0,55	0,75	32	30	28,5	27	25	23	22	15	8	159,00
4SP8-07	302	3,4	1 ½	0,75	1,0	45	42	39	36	34	32	31	21	11	195,00
4SP8-10	368	4,3	1 ½	1,1	1,5	64	60	56	52,5	49	45	44	30	16	250,00
4SP8-12	412	4,9	1 ½	1,5	2,0	76	72	67,5	63,5	59	54	53	36	19	286,00
4SP8-15	478	5,6	1 ½	2,2	3,0	95	90	85	80	74	68	66	45	24	340,00
4SP8-18	544	6,7	1 ½	2,2	3,0	115	108	101	95	88	81	79	54	29	394,00
4SP8-21	610	7,6	1 ½	3,0	4,0	134	126	119	111	103	95	92	63	33	449,00
4SP8-25	698	8,8	1 ½	3,0	4,0	159	150	140	132	123	113	110	75	40	521,00
4SP8-30	808	10,3	1 ½	4,0	5,5	191	180	169	159	147	135	132	90	48	625,00
4SP8-37	962	12,4	1 ½	4,0	5,5	235	221	208	195	181	167	163	111	59	751,00
4SP8-44	1.116	14,5	1 ½	5,5	7,5	280	265	250	235	219	202	194	126	70	878,00
4SP8-50	1.248	16,3	1 ½	5,5	7,5	318	300	281	263	245	225	220	150	80	987,00

4SP12 = QF12 = SP8						CAUDAL										P.V.P. C. BOMBA
MODELO	L	Peso	DN	P ₂		m ³ /h	0	1,4	2	4	6	8	9	10	11	
	mm	Kg	Ø"	kW	Hp	l/min	0	23	33	67	100	133	150	167	183	
						ALTURA DE CARGA EN METROS										
4SP12-05	289	3,0	2	0,75	1,0	30	29	27	25	23	21	19	16	12	217,00	
4SP12-07	349	3,6	2	1,1	1,5	42	40	38	35	32	29	26	22	17	254,00	
4SP12-10	439	5,1	2	1,5	2,0	60	57	55	50	46	41	37	32	24	308,00	
4SP12-12	499	6,1	2	2,2	3,0	72	68	66	61	57	51	45	39	31	345,00	
4SP12-15	589	7,5	2	2,2	3,0	90	85	82	76	70	62	56	47	37	399,00	
4SP12-18	679	9,0	2	3,0	4,0	108	102	99	91	84	75	67	57	45	452,00	
4SP12-21	769	10,5	2	4,0	5,5	127	120	117	107	99	89	80	68	53	514,00	
4SP12-25	889	12,5	2	4,0	5,5	150	142	139	126	116	104	94	79	62	588,00	
4SP12-30	1.039	15,0	2	5,5	7,5	180	170	165	151	138	123	110	92	71	670,00	
4SP12-37	1.249	17,0	2	5,5	7,5	221	210	202	184	168	148	132	110	84	797,00	
4SP12-40	1.299	18,6	2	7,5	10	232	228	224	207	192	172	151	128	100	862,00	
4SP12-44	1.411	21,9	2	7,5	10	255	249	246	227	211	189	167	141	110	949,00	
4SP12-50	1.579	24,3	2	7,5	10	290	284	280	258	240	215	190	160	120	1.078,00	

4SP25 = QF25 = SP14						CAUDAL							P.V.P. C. BOMBA
MODELO	L	Peso	DN	P ₂		m ³ /h	0	6	8	10	12	14	
	mm	Kg	Ø"	kW	Hp	l/min	0	100	133	167	200	233	300
						ALTURA DE CARGA EN METROS							
4SP25-05	349	3,6	2	1,5	2,0	35	29	28	27	25	22	14	298,00
4SP25-07	433	4,5	2	2,2	3,0	51	48	39	38	37	32	19	396,00
4SP25-10	559	5,8	2	3,0	4,0	69	62	55	54	51	45	27	490,00
4SP25-13	685	7,2	2	4,0	5,5	80	75	72	70	65	60	33	617,00
4SP25-15	809	8,0	2	5,5	7,5	102	87	83	80	74	63	54	645,00
4SP25-18	895	9,4	2	5,5	7,5	125	102	100	97	93	80	48	775,00
4SP25-25	1.189	12,6	2	7,5	10	173	140	138	134	131	112	67	1.151,00



IMPULSORES Y DIFUSORES
ACERO INOX 304

BOMBEO PARA POZO

HIDRÁULICAS INOX 6" SERIE SP



DESCRIPCIÓN

- Electrobombas sumergibles multicelurares completamente en INOX de 6" para pozos, acoplable a motores sumergibles tipo **NEMA**.
- Está construida por completo en acero inoxidable, de forma que cuenta con una **alta rigidez y resistencia a la corrosión** y con altos niveles de rendimiento.

MATERIALES

- Cuerpo de aspiración e impulsión: **Acero INOX 304**
- Válvula de retención: **Acero INOX 304**
- Eje: **Acero INOX 304**
- Impulsores: **Acero INOX 304**
- Difusores: **Acero INOX 304**

ÁREA DE TRABAJO

- Caudal máx.: **78 m³/h**
- Altura máx.: **489 mca**
- Rango de Potencia: **4,00 - 45,00 kW**
- Agua química y mecánicamente: **No agresiva**
- Contenido en sólido: **< 50 g/m³**
- Temperatura máx.: **Supeditada a t° máx. del motor.**



DISPONIBLE EN
50Hz Y 60Hz

BOMBEO PARA POZO

6SP14 = QF14 = SP12						CAUDAL						P.V.P. C. BOMBA	
MODELO	L	Peso	DN	P ₂		m³/h	0	10	12	14	17		20
	mm	Kg	Ø"	kW	Hp	l/min		167	200	233	283		333
ALTURA DE CARGA EN METROS													C
6SP14-04	446	7,1	2 ½	2,2	3,0	44	36	34	32	24	20	413,00	
6SP14-05	491	7,8	2 ½	2,2	3,0	55	45	43	40	30	25	462,00	
6SP14-06	536	8,6	2 ½	3,0	4,0	66	54	51	48	36	30	511,00	
6SP14-07	581	9,4	2 ½	4,0	5,5	77	63	60	56	42	35	560,00	
6SP14-09	671	11,1	2 ½	5,5	7,5	99	81	76,5	72	54	45	609,00	
6SP14-10	716	11,8	2 ½	5,5	7,5	110	90	85	80	60	50	657,00	
6SP14-11	761	12,6	2 ½	5,5	7,5	121	99	93,5	88	66	55	707,00	
6SP14-12	806	13,5	2 ½	5,5	7,5	132	108	102	96	72	60	756,00	
6SP14-13	851	14,2	2 ½	7,5	10	143	117	111	104	78	65	805,00	
6SP14-14	896	15,0	2 ½	7,5	10	154	126	119	112	84	70	855,00	
6SP14-15	941	15,7	2 ½	7,5	10	165	135	127,5	120	90	75	904,00	
6SP14-16	986	16,5	2 ½	7,5	10	176	144	136	128	96	80	954,00	
6SP14-17	1.031	17,4	2 ½	9,2	12,5	187	153	145	136	102	85	1.007,00	
6SP14-18	1.076	18,2	2 ½	9,2	12,5	198	162	153	144	108	90	1.032,00	
6SP14-20	1.166	19,8	2 ½	9,2	12,5	220	180	170	160	120	100	1.130,00	
6SP14-21	1.211	20,6	2 ½	11	15	231	189	179	168	126	105	1.175,00	
6SP14-22	1.256	21,4	2 ½	11	15	242	198	187	176	132	110	1.212,00	
6SP14-24	1.346	23	2 ½	11	15	264	216	204	192	144	120	1.307,00	
6SP14-25	1.391	23,8	2 ½	13	17,5	275	225	212,5	200	150	125	1.357,00	
6SP14-26	1.436	24,5	2 ½	13	17,5	286	234	221	208	156	130	1.402,00	
6SP14-27	1.481	23,4	2 ½	13	17,5	297	243	230	216	162	135	1.451,00	
6SP14-30	1.616	29,7	2 ½	15	20	330	270	255	240	180	150	1.553,00	
6SP14-31	1.684	30,6	2 ½	15	20	341	279	264	248	186	155	1.599,00	
6SP14-32	1.729	31,5	2 ½	15	20	352	288	272	256	192	160	1.648,00	
6SP14-33	1.774	32,2	2 ½	15	20	363	297	281	264	198	165	1.673,00	
6SP14-35	1.864	33,8	2 ½	18,5	25	385	315	298	280	210	175	1.763,00	
6SP14-36	1.909	34,5	2 ½	18,5	25	396	324	306	288	216	180	1.813,00	
6SP14-38	1.999	36,2	2 ½	18,5	25	418	342	323	304	228	190	1.879,00	
6SP14-40	2.089	37,8	2 ½	18,5	25	440	360	340	320	240	200	1.968,00	

Hidráulicas: Hasta 10Hp opción acoplamiento a motor de 4" y 6". A partir de 10Hp acoplamiento a motor de 6". Opción doble pasacable para arranque AET. P.V.P.: 31,50

6SP30 = QF30 = SP17						CAUDAL											P.V.P. C. BOMBA													
						ALTURA DE CARGA EN METROS																								
MODELO	L	Peso	DN	P ₂													C													
	mm	Kg	Ø"	kW	Hp	m ³ /h	0	2	4	6	8	10	12	14	16	18		20	22	l/min	0	33	67	100	133	167	200	233	267	300
6SP30-06	558	8,9	2 ½	4,0	5,5	68	67	67	66	65	63	59	55	50	45	38	31	456,00												
6SP30-07	607	9,9	2 ½	4,0	5,5	78	78	78	77	75	72	68	64	58	52	44	35	506,00												
6SP30-08	656	10,9	2 ½	5,5	7,5	90	90	90	89	87	84	80	74	68	61	52	42	555,00												
6SP30-09	705	12,0	2 ½	5,5	7,5	101	101	100	99	97	94	89	83	76	67	58	46	609,00												
6SP30-10	754	13,0	2 ½	5,5	7,5	112	111	111	110	107	103	98	91	83	74	63	50	657,00												
6SP30-11	803	14,0	2 ½	7,5	10	124	124	123	122	119	115	110	102	94	84	72	58	690,00												
6SP30-12	852	14,9	2 ½	7,5	10	135	134	134	132	130	125	119	111	101	90	77	62	756,00												
6SP30-13	901	16,0	2 ½	7,5	10	145	145	144	143	140	135	128	119	109	97	83	66	814,00												
6SP30-14	950	16,9	2 ½	9,2	12,5	157	157	156	155	152	147	139	130	119	106	91	74	863,00												
6SP30-15	999	18,0	2 ½	9,2	12,5	168	168	167	165	162	156	149	139	127	113	97	78	908,00												
6SP30-16	1.048	19,1	2 ½	9,2	12,5	179	178	178	176	172	166	158	147	134	119	102	82	954,00												
6SP30-17	1.097	20,2	2 ½	9,2	12,5	189	189	188	186	182	175	166	155	141	126	107	86	999,00												
6SP30-18	1.146	21,2	2 ½	11	15	202	201	200	199	194	188	178	167	152	136	116	94	1.049,00												
6SP30-19	1.195	22,2	2 ½	11	15	212	212	211	209	204	197	187	175	160	142	121	97	1.093,00												
6SP30-20	1.244	23,3	2 ½	11	15	223	222	221	219	214	207	196	183	167	148	126	101	1.142,00												
6SP30-21	1.293	24,3	2 ½	13	17,5	235	235	234	232	227	220	209	195	179	159	137	110	1.192,00												
6SP30-22	1.342	25,3	2 ½	13	17,5	246	246	245	243	237	229	218	204	186	166	142	114	1.237,00												
6SP30-23	1.391	26,4	2 ½	13	17,5	257	256	255	253	248	239	227	212	193	172	147	118	1.286,00												
6SP30-24	1.440	27,4	2 ½	13	17,5	267	267	266	263	258	248	236	220	201	178	152	122	1.332,00												
6SP30-25	1.489	28,4	2 ½	15	20	280	279	279	276	270	261	248	232	212	189	162	131	1.381,00												
6SP30-26	1.538	29,5	2 ½	15	20	291	290	289	286	280	271	257	240	220	196	168	135	1.422,00												
6SP30-27	1.587	30,5	2 ½	15	20	301	300	300	297	290	280	266	249	227	202	173	139	1.472,00												
6SP30-28	1.636	31,5	2 ½	18,5	25	315	314	314	311	305	295	281	263	241	215	186	151	1.517,00												
6SP30-29	1.685	32,6	2 ½	18,5	25	326	325	324	321	315	305	290	272	249	222	191	155	1.566,00												
6SP30-30	1.734	33,6	2 ½	18,5	25	336	336	335	332	325	315	299	280	257	229	197	159	1.615,00												
6SP30-31	1.783	34,6	2 ½	18,5	25	347	346	346	342	336	324	309	289	264	236	202	163	1.664,00												
6SP30-32	1.832	35,6	2 ½	18,5	25	358	357	356	353	346	334	318	297	272	242	208	168	1.710,00												
6SP30-33	1.881	36,6	2 ½	18,5	25	368	368	367	363	356	344	327	305	279	249	213	172	1.759,00												
6SP30-34	1.930	37,8	2 ½	22	30	382	381	380	377	369	357	340	318	291	260	223	181	1.805,00												
6SP30-35	1.979	39,0	2 ½	22	30	392	392	391	387	380	367	349	326	299	266	229	185	1.854,00												
6SP30-36	2.028	40,0	2 ½	22	30	403	402	401	398	390	377	358	335	306	273	234	189	1.899,00												
6SP30-37	2.077	41,0	2 ½	22	30	414	413	412	408	400	386	367	343	314	279	240	193	1.949,00												
6SP30-38	2.126	41,8	2 ½	22	30	425	424	423	418	410	396	376	351	321	286	245	197	1.997,00												
6SP30-39	2.175	43,0	2 ½	22	30	435	434	433	429	420	405	385	360	328	292	250	201	2.047,00												
6SP30-40	2.224	43,9	2 ½	22	30	446	445	444	439	430	415	394	368	336	298	255	205	2.096,00												

Hidráulicas: Hasta 10Hp opción acoplamiento a motor de 4" y 6". A partir de 10Hp acoplamiento a motor de 6".
Opción doble pasacable para arranque AET. P.V.P.: 31,50

6SP40 = SP20 = QF20						CAUDAL													C P.V.P. C. BOMBA
MODELO	L	Peso	DN	P ₂		m ³ /h	0	7,2	9,6	12	14,4	16,8	19,2	21,6	24	26,4	28,8	30	
	mm	Kg	Ø"	kW	Hp	l/min	0	120	160	200	240	300	320	360	400	440	480	500	
						ALTURA DE CARGA EN METROS													
						11	10	9,8	9,5	9	8,8	8,1	7,5	6,3	5,8	4	3	206,00	
6SP40-01	313	3,5	2 ½"	0,75	1,0	23	22	21	20	19	18	17	14	13	10	8	6	249,00	
6SP40-02	362	4,6	2 ½"	1,5	2,0	34	33	30	29	28	25	22	20	18	15	12	10	311,00	
6SP40-03	411	5,7	2 ½"	2,2	3,0	45	40	38	37	35	33	30	28	25	20	15	13	361,00	
6SP40-04	460	6,8	2 ½"	3,0	4,0	68	62	59	56	53	50	46	41	36	29	24	19	456,00	
6SP40-06	558	9,0	2 ½"	4,0	5,5	102	95	91	86	82	76	70	62	54	45	35	29	609,00	
6SP40-09	705	12,3	2 ½"	5,5	7,5	125	115	110	104	98	91	83	74	65	55	43	35	690,00	
6SP40-11	803	14,5	2 ½"	7,5	10	159	145	139	133	125	116	105	95	83	70	54	45	863,00	
6SP40-14	950	17,8	2 ½"	9,2	12,5	193	178	170	160	150	140	127	113	98	83	66	55	999,00	
6SP40-17	1.097	21,1	2 ½"	11	15	227	207	197	187	175	162	147	131	115	95	75	64	1.142,00	
6SP40-20	1.244	24,4	2 ½"	13	17,5	272	249	237	224	210	193	177	159	138	116	92	77	1.332,00	
6SP40-24	1.440	28,8	2 ½"	15	20	317	277	263	245	228	207	185	160	135	106	93	90	1.517,00	
6SP40-28	1.636	33,2	2 ½"	18,5	25	385	359	341	321	300	275	250	221	192	161	130	110	1.805,00	
6SP40-34	1.930	39,8	2 ½"	22	30	453	410	392	371	348	322	294	263	230	193	152	129	2.096,00	

Hidráulicas: Hasta 10Hp opción acoplamiento a motor de 4" y 6". A partir de 10Hp acoplamiento a motor de 6". Opción doble pasacable para arranque AET. P.V.P.: 31,50

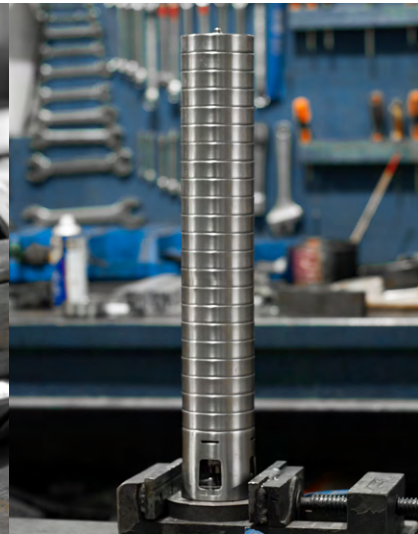
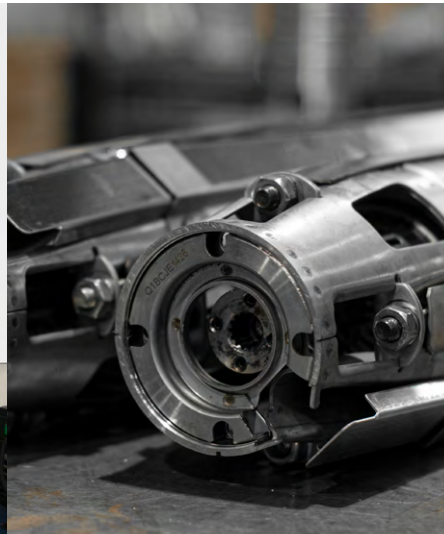

6SP50 = QF50 = SP30						CAUDAL										P.V.P. C. BOMBA
						m ³ /h	0	4	8	12	16	20	24	28	32	
MODELO	L	Peso	DN	P ₂		ALTURA DE CARGA EN METROS										C. BOMBA
	mm	Kg	Ø"	kW	Hp	0	4	8	12	16	20	24	28	32	39	
6SP50-04	650	10,7	3	4,0	5,5	46	46	45	43	40	38	35	32	27	16	502,00
6SP50-05	746	12,5	3	5,5	7,5	58	58	56	54	51	48	45	41	35	22	559,00
6SP50-06	842	14,3	3	5,5	7,5	69	69	67	64	60	57	53	48	41	25	621,00
6SP50-07	938	16,1	3	7,5	10	80	81	79	75	71	67	63	57	49	31	690,00
6SP50-08	1.034	17,9	3	7,5	10	91	92	89	85	80	76	71	64	55	34	756,00
6SP50-09	1.130	19,7	3	9,2	12,5	103	104	101	96	91	86	80	73	63	39	822,00
6SP50-10	1.226	21,5	3	9,2	12,5	114	115	111	106	100	95	88	80	69	43	884,00
6SP50-11	1.322	23,3	3	9,2	12,5	125	125	122	116	110	103	96	87	75	46	970,00
6SP50-12	1.418	25,1	3	11	15	137	137	134	127	121	114	106	97	83	51	1.032,00
6SP50-13	1.514	26,9	3	11	15	148	148	144	137	130	122	114	103	89	55	1.082,00
6SP50-14	1.610	28,7	3	13	17,5	160	161	156	149	141	133	125	113	98	61	1.138,00
6SP50-15	1.706	30,5	3	13	17,5	171	171	167	159	150	142	132	120	104	64	1.200,00
6SP50-16	1.802	32,3	3	15	20	183	184	179	171	162	153	143	130	112	70	1.258,00
6SP50-17	1.898	34,1	3	15	20	194	195	189	180	171	161	151	137	118	74	1.324,00
6SP50-18	1.994	35,9	3	18,5	25	207	208	202	193	183	173	163	148	129	82	1.381,00
6SP50-19	2.090	37,7	3	18,5	25	218	219	213	203	193	182	171	156	135	85	1.443,00
6SP50-20	2.186	39,5	3	18,5	25	229	230	223	213	202	191	179	163	141	89	1.505,00
6SP50-21	2.282	41,3	3	18,5	25	240	241	234	223	212	200	187	170	147	92	1.566,00
6SP50-22	2.378	43,1	3	22	30	252	253	246	235	223	211	198	180	156	99	1.599,00
6SP50-23	2.474	44,9	3	22	30	263	264	257	245	233	220	206	188	162	102	1.660,00
6SP50-24	2.570	46,7	3	22	30	274	275	268	255	242	228	214	195	168	105	1.722,00
6SP50-25	2.666	47,7	3	22	30	285	286	278	265	251	237	221	201	174	108	1.780,00
6SP50-26	2.762	50,3	3	22	30	296	297	288	275	260	245	229	208	179	111	1.842,00
6SP50-27	2.858	52,1	3	26	35	309	310	302	288	274	259	242	221	191	121	1.903,00
6SP50-28	2.954	53,9	3	26	35	320	321	313	298	283	267	250	228	197	124	1.960,00
6SP50-29	3.050	55,7	3	26	35	331	332	323	308	292	276	258	235	203	127	2.022,00
6SP50-30	3.146	57,5	3	26	35	342	343	333	318	301	284	266	242	209	130	2.051,00
6SP50-31	3.242	59,3	3	26	35	353	354	344	328	310	293	274	249	215	133	2.108,00
6SP50-32	3.338	61,1	3	30	40	367	368	358	342	324	306	287	262	227	143	2.166,00
6SP50-33	3.434	62,9	3	30	40	378	379	369	352	334	315	295	269	232	146	2.228,00
6SP50-34	3.530	64,7	3	30	40	389	390	379	362	343	324	303	276	238	149	2.286,00
6SP50-35	3.626	66,5	3	30	40	399	401	390	372	352	332	310	283	244	152	2.347,00
6SP50-39	3.722	68,3	3	37	50	445	447	435	416	395	374	351	320	278	176	2.589,00

Hidráulicas: Hasta 10Hp opción acoplamiento a motor de 4" y 6". A partir de 10Hp acoplamiento a motor de 6". Opción doble pasacable para arranque AET. P.V.P.: 31,50

HIDRÁULICAS INOX 6" SERIE SP



BOMBEO PARA POZO

6SP75 = QF75 = SP46						CAUDAL												P.V.P. C C. BOMBA	
MODELO	L mm	Peso Kg	DN Ø"	P ₂		m ³ /h	0	5	10	15	20	25	30	35	40	45	50		55
				kW	Hp	l/min	0	83	167	250	333	417	500	583	667	750	833	917	1000
						ALTURA DE CARGA EN METROS													
6SP75-03	609	10,1	4	5,5	7,5	41	41	40	38	36	34	32	30	28	26	23	20	15	506,00
6SP75-04	722	12,6	4	7,5	10	54	53	52	50	48	46	44	41	38	35	31	26	20	580,00
6SP75-05	835	15,1	4	7,5	10	67	66	64	62	60	57	54	51	47	43	37	31	24	642,00
6SP75-06	948	17,6	4	9,2	12,5	81	79	77	75	72	68	65	61	57	51	45	38	30	707,00
6SP75-07	1.061	20,1	4	11	15	94	93	90	87	84	80	76	72	66	60	53	45	35	830,00
6SP75-08	1.174	22,6	4	13	17,5	108	106	104	100	96	92	88	83	77	70	62	52	41	896,00
6SP75-09	1.87	25,1	4	15	20	122	120	117	113	109	104	99	93	87	79	70	59	47	962,00
6SP75-10	1.400	27,6	4	15	20	135	132	129	125	120	115	109	103	95	87	77	65	51	1.028,00
6SP75-11	1.513	30,1	4	18,5	25	149	147	143	138	133	128	122	115	107	97	86	73	59	1.105,00
6SP75-12	1.626	32,6	4	18,5	25	162	159	155	150	145	138	132	124	115	105	93	79	63	1.175,00
6SP75-13	1.739	35,1	4	22	30	176	173	169	163	157	151	143	135	126	115	102	86	69	1.245,00
6SP75-14	1.852	37,6	4	22	30	189	186	181	175	169	161	153	144	134	122	108	92	73	1.311,00
6SP75-15	1.965	40,1	4	22	30	202	198	193	187	180	172	163	154	143	130	115	97	77	1.381,00
6SP75-16	2.078	42,6	4	26	35	217	213	208	201	193	185	176	166	155	141	125	106	85	1.427,00
6SP75-17	2.191	45,1	4	26	35	229	226	220	213	205	196	186	175	163	149	132	112	89	1.492,00
6SP75-18	2.304	47,6	4	30	40	244	241	234	227	219	209	199	188	175	160	142	121	97	1.557,00
6SP75-19	2.417	50,1	4	30	40	257	253	247	239	230	220	209	197	183	167	148	126	101	1.627,00
6SP75-20	2.530	52,6	4	30	40	270	265	259	251	241	230	219	206	192	175	155	132	105	1.693,00
6SP75-21	2.643	55,1	4	37	50	285	280	273	265	255	245	234	221	206	188	167	143	115	1.763,00
6SP75-22	2.756	57,6	4	37	50	298	293	286	277	267	256	244	230	215	196	174	148	119	1.829,00
6SP75-23	2.869	60,1	4	37	50	311	306	298	289	278	267	254	240	223	204	181	154	124	1.899,00
6SP75-24	2.982	62,6	4	37	50	324	318	310	300	289	277	264	249	232	212	188	160	128	1.964,00
6SP75-25	3.139	60,2	4	45	60	350	342	335	325	310	290	266	250	233	215	190	165	140	2.610,00
6SP75-26	3.253	65,1	4	45	60	357	351	343	332	321	308	295	279	261	239	214	183	149	2.715,00
6SP75-28	3.481	67,6	4	45	60	383	377	368	357	345	331	316	299	280	256	229	196	159	3.023,00
6SP75-30	3.709	70,1	4	45	60	410	403	393	381	368	353	337	319	298	273	244	208	169	3.228,00

Hidráulicas: Hasta 10Hp opción acoplamiento a motor de 4" y 6". A partir de 10Hp acoplamiento a motor de 6". Opción doble pasacable para arranque AET. P.V.P.: 31,50

6SP100 = QF100 = SP60						CAUDAL								P.V.P. C C. BOMBA					
MODELO	L mm	Peso Kg	DN Ø"	P ₂		m ³ /h	0	10	20	30	40	50	60		70	78			
				kW	Hp	l/min	0	167	333	500	667	833	1000	1167	1300				
						ALTURA DE CARGA EN METROS													
6SP100-02	496	8,5	4	4,0	5,5	28	27	26	23	19	17	14	10	5	448,00				
6SP100-03	609	10,7	4	5,5	7,5	42	41	39	35	30	26	22	16	10	510,00				
6SP100-04	722	13,0	4	7,5	10	56	55	52	47	41	35	30	22	14	584,00				
6SP100-05	835	15,3	4	9,2	12,5	71	69	66	59	51	44	38	28	18	657,00				
6SP100-06	946	17,5	4	11	15	85	83	79	71	62	54	45	34	22	727,00				
6SP100-07	1.061	19,8	4	13	17,5	99	97	92	83	73	63	53	40	26	805,00				
6SP100-08	1.174	22,01	4	15	20	114	112	106	96	84	73	61	47	31	876,00				
6SP100-09	1.287	24,3	4	18,5	25	129	127	121	109	95	83	71	54	37	946,00				
6SP100-10	1.400	25,5	4	18,5	25	143	140	133	120	105	92	78	60	41	1.020,00				
6SP100-11	1.513	26,8	4	22	30	158	154	147	133	116	101	86	67	45	1.089,00				
6SP100-12	1.626	31,0	4	22	30	171	167	159	144	126	110	94	72	50	1.155,00				
6SP100-13	1.739	33,3	4	26	35	187	183	174	157	138	120	103	79	54	1.221,00				
6SP100-14	1.852	35,5	4	26	35	200	196	186	168	148	129	110	85	58	1.291,00				
6SP100-15	1.965	37,8	4	26	35	214	209	198	179	157	136	116	89	60	1.357,00				
6SP100-16	2.078	40,0	4	30	40	230	224	213	192	169	147	125	96	65	1.427,00				
6SP100-17	2.191	42,3	4	30	40	243	237	225	203	179	155	132	101	69	1.492,00				
6SP100-18	2.304	44,5	4	37	50	260	254	242	219	193	168	143	111	77	1.561,00				
6SP100-19	2.417	46,8	4	37	50	274	268	255	231	203	177	151	117	81	1.627,00				
6SP100-20	2.530	49,0	4	37	50	287	281	267	242	213	186	158	123	85	1.693,00				
6SP100-21	2.643	51,3	4	37	50	301	294	279	253	223	194	166	129	89	2.099,00				
6SP100-22	2.756	53,6	4	45	60	323	316	302	274	242	211	181	142	100	2.306,00				

Hidráulicas: Hasta 10Hp opción acoplamiento a motor de 4" y 6". A partir de 10Hp acoplamiento a motor de 6". Opción doble pasacable para arranque AET. P.V.P.: 31,50

DESCRIPCIÓN

- Electrobombas sumergibles multicelulares completamente en INOX de 8" para pozos, acoplable a motores sumergibles tipo **NEMA** hasta 8".
- Está construida por completo en acero inoxidable, de forma que cuenta con una **alta rigidez y resistencia a la corrosión** y con altos niveles de rendimiento.

MATERIALES

- Cuerpo de aspiración e impulsión: **Acero**
- **INOX 304**
- Válvula de retención: **Acero INOX 304**
- Eje: **Acero INOX 304**
- Impulsores: **Acero INOX 304**
- Difusores: **Acero INOX 304**

ÁREA DE TRABAJO

- Caudal máx.: **150 m³/h**
- Altura máx.: **423 mca**
- Rango de Potencia: **5,50 - 63,00 kW**
- Agua química y mecánicamente: **No agresiva**
- Contenido en sólido: **< 50 g/m³**
- Temperatura máx.: **Supeditada a tº máx. del motor.**



DISPONIBLE EN
50Hz Y 60Hz

8SP125 = QF125 = SP77						CAUDAL										P.V.P. C. BOMBA		
MODELO	L mm	Peso Kg	DN Ø"	P ₂ kW	Hp	m³/h	0	10	20	30	40	50	60	70	80		90	100
						l/min	0	167	333	500	667	833	1000	1167	1333	1500	1667	
							ALTURA DE CARGA EN METROS											
8SP125-01	392	13,2	5	5,5	7,5		21	21	20	18	17	15	14	13	12	10	7	896,00
8SP125-02	496	16,4	5	7,5	10		41	40	39	36	33	31	28	26	23	18	13	1.019,00
8SP125-03	600	19,5	5	11	15		61	60	58	55	50	46	42	39	34	28	20	1.143,00
8SP125-04	704	22,7	5	15	20		81	80	78	73	68	62	57	52	46	38	27	1.300,00
8SP125-05	808	25,9	5	18,5	25		100	100	97	92	85	78	72	66	58	47	34	1.341,00
8SP125-06	912	29,0	5	22	30		120	120	116	110	102	94	86	78	69	56	41	1.361,00
8SP125-07	1.016	32,2	5	26	35		140	140	136	129	119	110	101	92	81	66	48	1.777,00
8SP125-08	1.120	35,4	5	30	40		160	160	156	147	137	126	116	105	93	76	55	1.858,00
8SP125-09	1.224	38,6	5	30	40		179	179	174	164	152	140	129	117	103	85	61	1.935,00
8SP125-10	1.328	41,7	5	37,5	50		199	199	194	184	171	157	145	132	117	96	69	2.061,00
8SP125-11	1.432	44,9	5	37,5	50		218	218	212	201	186	172	158	144	127	104	74	2.287,00
8SP125-12	1.536	48,7	5	45	60		242	243	237	225	209	193	178	163	145	120	88	2.502,00
8SP125-13	1.640	51,2	5	55	75		264	264	258	245	228	211	195	178	159	132	98	2.760,00
8SP125-14	1.744	53,7	5	55	75		283	284	277	263	245	226	209	191	170	141	104	2.890,00
8SP125-15	1.848	57,6	5	55	75		303	303	296	281	262	242	223	204	181	150	110	3.222,00
8SP125-16	1.952	60,7	5	63	85		324	325	317	301	281	259	239	219	195	162	119	3.357,00
8SP125-17	2.056	63,8	5	63	85		343	344	336	319	297	274	253	232	206	171	126	3.482,00
8SP125-18	2.160	67,0	5	63	85		363	363	355	336	314	290	267	244	217	180	132	3.510,00
8SP125-19	2.264	69,5	5	75	100		383	384	376	357	332	307	283	259	230	191	140	3.743,00
8SP125-20	2.368	73,4	5	75	100		402	405	395	375	349	322	297	271	241	200	146	3.873,00

Hidráulicas: Hasta 50Hp opción acoplamiento a motor de 6". A partir de 60Hp acoplamiento a motor de 8". Opción doble pasacable para arranque AET. P.V.P.: 47,00

HIDRÁULICAS INOX 8" SERIE SP



BOMBEO PARA POZO

8SP160 = QF160 = SP95						CAUDAL											P.V.P. C. BOMBA		
						m ³ /h	0	10	20	30	40	50	60	70	80	90		100	110
MODELO						CAUDAL											P.V.P. C. BOMBA		
						l/min	0	167	333	500	667	833	1000	1167	1333	1500		1667	1833
MODELO	L	Peso	DN	P ₂		ALTURA DE CARGA EN METROS											P.V.P. C. BOMBA		
	mm	Kg	ø"	kW	Hp	23	22	21	20	18	17	15	14	13	13	11		9	6
8SP160-01	418	13,2	5	5,5	7,5	23	22	21	20	18	17	15	14	13	13	11	9	6	793,00
8SP160-02	544	17,0	5	9,2	12,5	44	43	41	39	36	33	31	29	27	25	22	17	13	916,00
8SP160-03	672	20,8	5	13	17,5	65	64	62	58	55	51	47	44	42	38	33	27	20	1.037,00
8SP160-04	800	24,6	5	18,5	25	86	84	82	78	73	67	63	59	55	51	44	36	26	1.196,00
8SP160-05	928	28,4	5	22	30	106	105	101	96	90	84	78	73	69	63	55	44	32	1.258,00
8SP160-06	1.056	32,2	5	26	35	129	127	123	117	110	102	96	90	84	77	68	55	41	1.396,00
8SP160-07	1.184	35,9	5	30	40	148	146	142	135	126	118	110	103	96	88	77	62	46	1.477,00
8SP160-08	1.312	39,7	5	37	50	170	167	163	155	145	136	127	119	112	102	90	73	54	1.690,00
8SP160-09	1.440	43,5	5	37	50	189	187	182	173	162	151	141	133	124	114	99	80	59	1.816,00
8SP160-10	1.568	47,3	5	45	60	214	212	206	197	185	173	162	152	143	132	116	95	71	2.032,00
8SP160-11	1.696	51,1	5	55	75	237	234	228	217	205	191	179	169	158	146	129	106	79	2.158,00
8SP160-12	1.824	54,9	5	55	75	257	254	248	236	222	208	195	183	172	158	140	115	86	2.316,00
8SP160-13	1.952	58,7	5	55	75	278	275	267	255	240	224	210	198	185	170	150	123	92	2.450,00
8SP160-14	2.080	62,5	5	63	85	300	297	289	276	259	243	227	214	201	185	163	134	100	2.684,00
8SP160-15	2.208	66,2	5	75	100	321	318	310	296	278	260	244	230	215	198	175	144	107	2.810,00
8SP160-16	2.336	70,0	5	75	100	342	338	329	314	296	277	259	244	229	211	186	152	114	2.945,00
8SP160-17	2.464	73,4	5	75	100	362	358	349	333	313	293	275	258	242	223	196	160	120	3.070,00
8SP160-18	2.592	77,6	5	92	125	382	378	368	352	331	309	290	272	255	235	206	169	125	3.720,00
8SP160-19	2.720	81,4	5	92	125	402	398	388	370	348	325	305	287	269	247	216	177	131	3.891,00
8SP160-20	2.848	85,2	5	92	125	423	418	407	388	365	341	320	301	281	258	226	184	137	3.957,00

Hidráulicas: Hasta 10Hp opción acoplamiento a motor de 4". Motores: 6" desde 5,5 Hp hasta 50 Hp.
Opción doble pasacable para arranque AET. P.V.P.: 47,00

8SP180 = SP110						CAUDAL								P.V.P. C. BOMBA			
MODELO						m ³ /h	0	15	30	45	60	75	90		105	120	135
						l/min	0	250	500	750	1000	1250	1500	1750	2000	2250	
MODELO	L	Peso	DN	P ₂		ALTURA DE CARGA EN METROS											P.V.P. C. BOMBA
	mm	Kg	ø"	kW	Hp	22	21,9	21,8	21	19	17	15	13	10	7	907,00	
8SP180-01	510	16,0	5	7,5	10	22	21,9	21,8	21	19	17	15	13	10	7	907,00	
8SP180-02	638	19,9	5	13	17,5	44	43	42	38	36	32	29	25	20	16	1.076,00	
8SP180-03	766	23,7	5	18,5	25	66	65	64	63	58	54	47	40	32	23	1.262,00	
8SP180-04	894	27,5	5	22	30	88	87	86	80	73	66	57	48	38	27	1.435,00	
8SP180-05	1.022	31,2	5	30	40	110	106	102	95	87	77	67	55	43	31	1.625,00	
8SP180-06	1.150	35,1	5	37	50	132	131	125	116	104	92	77	63	49	34	1.807,00	
8SP180-07	1.278	38,2	5	45	60	154	150	144	134	120	106	91	75	57	40	1.984,00	
8SP180-08	1.406	42,0	5	55	75	176	171	163	151	136	119	103	84	64	45	2.161,00	
8SP180-09	1.534	45,3	5	55	75	198	195	185	171	154	135	115	94	74	50	2.342,00	
8SP180-10	1.662	50,2	5	63	85	220	219	209	193	174	151	127	104	78	55	2.650,00	

Hidráulicas: Hasta 10Hp opción acoplamiento a motor de 4" y 6". A partir de 10Hp acoplamiento a motor de 6".
Opción doble pasacable para arranque AET. P.V.P.: 47,00

DESCRIPCIÓN

- Electrobombas sumergibles multicelulares completamente en INOX de 10" para pozos, acoplable a motores sumergibles tipo **NEMA** hasta 8".
- Está construida por completo en acero inoxidable, de forma que cuenta con una **alta rigidez y resistencia a la corrosión** y con altos niveles de rendimiento.

MATERIALES

- Cuerpo de aspiración e impulsión: **Acero INOX 304**
- Válvula de retención: **Acero INOX 304**
- Eje: **Acero INOX 304**
- Impulsores: **Acero INOX 304**
- Difusores: **Acero INOX 304**

ÁREA DE TRABAJO

- Caudal máx.: **200 m³/h**
- Altura máx.: **284 mca**
- Rango de Potencia: **11,00 - 110,00 kW**
- Agua química y mecánicamente: **No agresiva**
- Contenido en sólido: **< 50 g/m³**
- Temperatura máx.: **Supeditada a tº máx. del motor.**



DISPONIBLE EN
50Hz Y 60Hz

						CAUDAL													
						m³/h	0	60	70	80	90	100	110	120	130	140	150	160	
						l/min	0	1000	1167	1333	1500	1667	1833	2000	2167	2333	2500	2667	
10SP210 = QF210 = SP125																	P.V.P. C. BOMBA		
MODELO	L	Peso	DN	P ₂		ALTURA DE CARGA EN METROS													
	mm	Kg	Ø"	kW	Hp														
10SP210-01	592	25,0	6	11	15	30	27	25	24	23	22	21	20	19	17	15	13	1.245,00	
10SP210-02	738	32,0	6	22	30	59	54	52	50	48	46	44	42	39	35	32	27	1.570,00	
10SP210-03	884	40,0	6	30	40	88	80	77	74	72	69	66	62	58	53	47	40	1.869,00	
10SP210-04	1.030	48,0	6	37	50	116	106	102	99	95	91	87	83	77	71	63	54	2.195,00	
10SP210-05	1.176	56,0	6	55	75	146	137	132	127	123	118	114	108	102	93	84	72	2.524,00	
10SP210-06	1.322	63,0	6	63	85	175	164	158	153	147	142	136	130	122	112	100	87	2.836,00	
10SP210-07	1.488	70,0	6	75	100	204	191	184	178	172	165	159	151	142	130	117	101	3.157,00	
10SP210-08	1.614	78,0	6	92	125	232	216	209	202	195	188	180	171	160	147	131	113	3.461,00	
10SP210-09	1.760	86,0	6	92	125	260	242	234	226	218	209	201	191	178	163	146	125	3.781,00	

Motores: De 6" hasta 50 Hp. De 8" a partir de 60 Hp.
Opción doble pasacable para arranque AET. P.V.P.: 58,00
Por favor, especifique en su pedido el tipo de eje: **Estriado/chavetado.**

						CAUDAL															
						m³/h	0	80	90	100	110	120	130	140	150	160	170	180	190	200	
						l/min	0	1333	1500	1667	1833	2000	2167	2333	2500	2667	2833	3000	3167	3333	
10SP270 = QF270 = SP160																				P.V.P. C. BOMBA	
MODELO	L	Peso	DN	P ₂		ALTURA DE CARGA EN METROS															
	mm	Kg	Ø"	kW	Hp																
10SP270-01	602	26,0	6	13	17,5	34	28	26	25	24	23	22	22	21	20	19	18	16	14	1.266,00	
10SP270-02	758	34,0	6	26	35	65	55	52	50	48	46	45	43	42	40	38	35	32	28	1.604,00	
10SP270-03	914	42,0	6	37	50	96	82	78	75	72	70	68	65	63	60	57	53	48	42	1.924,00	
10SP270-04	1.070	50,0	6	55	75	129	111	107	103	100	96	93	90	87	83	79	74	67	60	2.258,00	
10SP270-05	1.226	58,0	6	63	85	161	139	133	129	124	120	116	113	109	104	98	91	83	74	2.583,00	
10SP270-06	1.382	66,0	6	75	100	192	166	159	154	148	144	139	135	130	124	117	109	99	88	2.912,00	
10SP270-07	1.538	74,0	6	92	125	222	191	184	177	171	166	161	155	150	143	135	125	113	101	3.280,00	
10SP270-08	1.694	82,0	6	92	125	252	217	208	201	194	188	182	176	169	161	152	140	127	113	3.616,00	
10SP270-09	1.850	90,0	6	110	150	284	245	236	227	220	213	206	199	192	183	172	160	145	129	3.950,00	

Hidráulicas: Hasta 50 Hp opción acoplamiento a motor de 6". A partir de 60 Hp hasta 125 Hp acoplamiento a motor de 8".
Opción doble pasacable para arranque AET. P.V.P.: 58,00
Por favor, especifique en su pedido el tipo de eje: **Estriado/chavetado.**

SEMIAXIALES INOX 6" SERIE IX

DESCRIPCIÓN

- Electrobombas sumergibles de 6" para pozo, con cuerpo difusor y rodete semiaxial en fundición de **acero inoxidable AISI 304** (bajo demanda en AISI 316) acoplable a motores sumergibles tipo **NEMA** hasta 8".
- Para evitar la fricción del impulsor contra el difusor se ha introducido en cada etapa un anillo de desgaste **EPDM**.



MATERIALES

- Cuerpo de aspiración e impulsión: **Acero INOX 304**
- Válvula de retención: **Acero INOX 304**
- Eje: **Acero INOX 304**
- Impulsores: **Acero INOX 304**
- Difusores: **Acero INOX 304**
- Anillo desgaste: **EPDM**

ÁREA DE TRABAJO

- Caudal máx.: **90 m³/h**
- Altura máx.: **386 mca**
- Rango de Potencia: **4,00 - 37,00 kW**
- Agua química y mecánicamente: **No agresiva**
- Contenido en sólido: **< 50 g/m³**
- Temperatura máx.: **Supeditada a t° máx. del motor.**



IX634

MODELO	L		Peso		DN	P ₂		CAUDAL								P.V.P. C. BOMBA
	mm	Kg	Kg	Ø"		kW	Hp	m³/h	l/min	0	18	24	30	36	42	
IX634/03	596	16,0	3	4,0	5,5	43	38	36	34	31	26	20	1.551,00			
IX634/04	697	20,0	3	5,5	7,5	57	51	48	45	41	35	27	1.829,00			
IX634/05	798	23,0	3	7,5	10	72	64	60	57	51	44	34	2.183,00			
IX634/06	899	27,0	3	9,2	12,5	86	76	72	68	61	52	41	2.490,00			
IX634/07	1.000	30,0	3	9,2	12,5	100	89	84	79	71	61	48	2.799,00			
IX634/08	1.101	33,0	3	11	15	114	102	96	90	82	70	54	3.106,00			
IX634/09	1.202	37,0	3	13	17,5	129	114	108	102	92	78	61	3.413,00			
IX634/10	1.303	40,0	3	15	20	143	127	120	113	102	87	68	3.721,00			
IX634/11	1.404	44,0	3	15	20	157	140	132	124	112	96	75	4.108,00			
IX634/12	1.505	47,0	3	18,5	25	172	152	144	136	122	104	82	4.411,00			
IX634/13	1.606	51,0	3	18,5	25	186	165	156	147	133	113	88	4.738,00			
IX634/14	1.707	54,0	3	22	30	200	178	168	158	143	122	95	5.043,00			
IX634/15	1.808	58,0	3	22	30	215	191	180	170	153	131	102	5.368,00			
IX634/16	1.909	61,0	3	22	30	229	203	192	181	163	139	109	5.676,00			
IX634/17	2.010	64,0	3	26	35	243	216	204	192	173	148	116	5.999,00			
IX634/18	2.111	68,0	3	26	35	257	229	216	203	184	157	122	6.304,00			
IX634/19	2.212	71,0	3	26	35	272	241	228	215	194	165	129	6.622,00			
IX634/20	2.313	75,0	3	30	40	286	254	240	226	204	174	136	6.927,00			
IX634/21	2.414	78,0	3	30	40	300	267	252	237	214	183	143	7.245,00			
IX634/22	2.515	82,0	3	30	40	315	279	264	249	224	191	150	7.550,00			
IX634/23	2.616	85,0	3	37	50	329	292	276	260	235	200	156	7.864,00			
IX634/24	2.717	89,0	3	37	50	343	305	288	271	245	209	163	8.169,00			
IX634/25	2.818	92,0	3	37	50	358	318	300	283	255	217	170	8.533,00			
IX634/26	2.919	96,0	3	37	50	372	330	312	294	265	226	177	8.838,00			
IX634/27	3.020	99,0	3	37	50	386	343	324	305	275	235	184	9.149,00			

Disponibile en AISI 316 bajo demanda. Opción **doble guardacable** para arranque AET. P.V.P.: 65,00. **Acoplamiento estriado** por defecto, disponible acoplamiento chaveteado bajo demanda. **Acoplamiento a motor:** De 6" hasta 50 Hp. De 8" hasta 125 Hp. De 10" a partir de 150 Hp.

SEMIAXIALES INOX 6" SERIE IX



IX644

MODELO	L mm	Peso Kg	DN Ø"	P ₂		CAUDAL								P.V.P. C. BOMBA
				kW	Hp	m ³ /h	0	24	30	36	42	48	54	
IX644/04	697	20,0	3	5,5	7,5	0	400	500	600	700	800	900	1000	1.858,00
IX644/05	798	23,0	3	7,5	10	0	400	500	600	700	800	900	1000	2.183,00
IX644/06	899	27,0	3	9,2	12,5	0	400	500	600	700	800	900	1000	2.490,00
IX644/07	1.000	30,0	3	11	15	0	400	500	600	700	800	900	1000	2.799,00
IX644/08	1.101	33,0	3	13	17,5	0	400	500	600	700	800	900	1000	3.106,00
IX644/09	1.202	37,0	3	13	17,5	0	400	500	600	700	800	900	1000	3.413,00
IX644/10	1.303	40,0	3	15	20	0	400	500	600	700	800	900	1000	3.721,00
IX644/11	1.404	44,0	3	18,5	25	0	400	500	600	700	800	900	1000	4.108,00
IX644/12	1.505	47,0	3	18,5	25	0	400	500	600	700	800	900	1000	4.411,00
IX644/13	1.606	51,0	3	22	30	0	400	500	600	700	800	900	1000	4.738,00
IX644/14	1.707	54,0	3	22	30	0	400	500	600	700	800	900	1000	5.043,00
IX644/15	1.808	58,0	3	22	30	0	400	500	600	700	800	900	1000	5.368,00
IX644/16	1.909	61,0	3	26	35	0	400	500	600	700	800	900	1000	5.676,00
IX644/17	2.010	64,0	3	26	35	0	400	500	600	700	800	900	1000	5.999,00
IX644/18	2.111	68,0	3	26	35	0	400	500	600	700	800	900	1000	6.304,00
IX644/19	2.212	71,0	3	30	40	0	400	500	600	700	800	900	1000	6.622,00
IX644/20	2.313	75,0	3	30	40	0	400	500	600	700	800	900	1000	6.927,00
IX644/21	2.414	78,0	3	37	50	0	400	500	600	700	800	900	1000	7.245,00
IX644/22	2.515	82,0	3	37	50	0	400	500	600	700	800	900	1000	7.550,00
IX644/23	2.616	85,0	3	37	50	0	400	500	600	700	800	900	1000	7.864,00
IX644/24	2.717	89,0	3	37	50	0	400	500	600	700	800	900	1000	8.169,00
IX644/25	2.818	92,0	3	37	50	0	400	500	600	700	800	900	1000	8.533,00

IX654

MODELO	L mm	Peso Kg	DN Ø"	P ₂		CAUDAL								P.V.P. C. BOMBA
				kW	Hp	m ³ /h	0	36	42	48	54	60	66	
IX654/03	614	19,0	3	5,5	7,5	0	600	700	800	900	1000	1100	1200	1.597,00
IX654/04	721	22,0	3	7,5	10	0	600	700	800	900	1000	1100	1200	1.904,00
IX654/05	828	26,0	3	9,2	12,5	0	600	700	800	900	1000	1100	1200	2.219,00
IX654/06	935	29,0	3	11	15	0	600	700	800	900	1000	1100	1200	2.533,00
IX654/07	1.042	32,0	3	13	17,5	0	600	700	800	900	1000	1100	1200	2.848,00
IX654/08	1.149	35,0	3	13	17,5	0	600	700	800	900	1000	1100	1200	3.162,00
IX654/09	1.256	38,0	3	15	20	0	600	700	800	900	1000	1100	1200	3.476,00
IX654/10	1.363	41,0	3	18,5	25	0	600	700	800	900	1000	1100	1200	3.791,00
IX654/11	1.470	45,0	3	18,5	25	0	600	700	800	900	1000	1100	1200	4.183,00
IX654/12	1.577	49,0	3	22	30	0	600	700	800	900	1000	1100	1200	4.495,00
IX654/13	1.684	53,0	3	22	30	0	600	700	800	900	1000	1100	1200	4.827,00
IX654/14	1.791	56,0	3	26	35	0	600	700	800	900	1000	1100	1200	5.139,00
IX654/15	1.898	59,0	3	26	35	0	600	700	800	900	1000	1100	1200	5.471,00
IX654/16	2.005	61,0	3	26	35	0	600	700	800	900	1000	1100	1200	5.787,00
IX654/17	2.112	64,0	3	30	40	0	600	700	800	900	1000	1100	1200	6.116,00
IX654/18	2.219	67,0	3	30	40	0	600	700	800	900	1000	1100	1200	6.442,00
IX654/19	2.326	70,0	3	37	50	0	600	700	800	900	1000	1100	1200	6.753,00
IX654/20	2.433	74,0	3	37	50	0	600	700	800	900	1000	1100	1200	7.078,00
IX654/21	2.540	77,0	3	37	50	0	600	700	800	900	1000	1100	1200	7.390,00
IX654/22	2.647	82,0	3	37	50	0	600	700	800	900	1000	1100	1200	7.712,00

Disponibile en AISI 316 bajo demanda. Opción doble guardacable para arranque AET. P.V.P.: 65,00. Acoplamiento estriado por defecto, disponible acoplamiento chaveteado bajo demanda. Acoplamiento a motor: De 6" hasta 50 Hp. De 8" hasta 125 Hp. De 10" a partir de 150 Hp.

IX664

CAUDAL										
m ³ /h	0	42	48	54	60	66	72	78	84	90
l/min	0	700	800	900	1000	1100	1200	1300	1400	1500

MODELO	L	Peso	DN	P ₂		ALTURA DE CARGA EN METROS										P.V.P. C. BOMBA
	mm	Kg	Ø"	kW	Hp	13	10	10	10	9	9	9	8	7	6	
IX664/01	400	12,0	3	2,2	3,0	13	10	10	10	9	9	9	8	7	6	1.005,00
IX664/02	507	15,0	3	4,0	5,5	26	21	20	19	19	18	17	15	13	11	1.302,00
IX664/03	614	19,0	3	7,5	10	39	31	30	29	28	27	26	23	20	17	1.598,00
IX664/04	721	23,0	3	9,2	12,5	52	41	40	38	37	36	34	31	27	23	1.907,00
IX664/05	828	27,0	3	11	15	66	52	50	48	47	45	43	38	33	28	2.221,00
IX664/06	935	32,0	3	13	17,5	79	62	59	57	56	55	51	46	40	34	2.537,00
IX664/07	1.042	36,0	3	15	20	92	73	69	67	66	64	60	53	46	39	2.851,00
IX664/08	1.149	40,0	3	18,5	25	105	83	79	76	75	73	68	61	53	45	3.166,00
IX664/09	1.256	44,0	3	22	30	118	93	89	86	84	82	77	69	60	51	3.481,00
IX664/10	1.363	48,0	3	22	30	131	104	99	95	94	91	85	76	66	56	3.796,00
IX664/11	1.470	53,0	3	26	35	144	114	109	105	103	100	94	84	73	62	4.189,00
IX664/12	1.577	57,0	3	26	35	157	124	119	114	112	109	102	92	80	68	4.501,00
IX664/13	1.684	61,0	3	30	40	170	135	129	124	122	118	111	99	86	73	4.833,00
IX664/14	1.791	65,0	3	30	40	183	145	139	134	131	127	120	107	93	79	5.145,00
IX664/15	1.898	70,0	3	37	50	197	155	149	143	140	136	128	114	99	84	5.478,00
IX664/16	2.005	75,0	3	37	50	210	166	158	153	150	145	137	122	106	90	5.795,00
IX664/17	2.112	80,0	3	37	50	223	176	168	162	159	155	145	130	113	96	6.124,00
IX664/18	2.219	85,0	3	37	50	236	186	178	172	168	164	154	137	119	101	6.450,00

BOMBEO PARA POZO

ANILLO DE DESGASTE

CAUCHO EPDM



Disponible en AISI 316 bajo demanda. Opción doble guardacable para arranque AET. P.V.P.: 65,00. Acoplamiento estriado por defecto, disponible acoplamiento chaveteado bajo demanda. Acoplamiento a motor: De 6" hasta 50 Hp. De 8" hasta 125 Hp. De 10" a partir de 150 Hp.

SEMIAXIALES INOX 8" SERIE IX



DESCRIPCIÓN

- Electrobombas sumergibles de 8" para pozo, con cuerpo difusor y rodete semiaxial en fundición de acero inoxidable AISI 304 (AISI 316 bajo demanda) acoplable a motores sumergibles tipo NEMA hasta 10".
- Para evitar la fricción del impulsor contra el difusor se ha introducido en cada etapa un anillo de desgaste EPDM.

MATERIALES

- Cuerpo de aspiración e impulsión: **Acero INOX 304**
- Válvula de retención: **Acero INOX 304**
- Eje: **Acero INOX 304**
- Impulsores: **Acero INOX 304**
- Difusores: **Acero INOX 304**
- Anillo desgaste: **EPDM**

ÁREA DE TRABAJO

- Caudal máx.: **192 m³/h**
- Altura máx.: **523 mca**
- Rango de Potencia: **7,50 - 110,00 kW**
- Agua química y mecánicamente: **No agresiva**
- Contenido en sólido: **< 50 g/m³**
- Temperatura máx.: **Supeditada a tº máx. del motor.**



IX878

MODELO	L mm	Peso Kg	DN Ø"	P ₂ kW	P ₂ Hp	CAUDAL							P.V.P. C. BOMBA	
						m³/h	0	36	48	60	72	84		96
						l/min	0	600	800	1000	1200	1400		1600
						ALTURA DE CARGA EN METROS								
IX878/01	525	19,0	5	7,5	10	27	24	23	22	20	18	15	2.275,00	
IX878/02	650	26,0	5	11	15	54	49	47	44	40	35	30	2.855,00	
IX878/03	775	32,0	5	18,5	25	81	73	70	65	60	53	44	3.467,00	
IX878/04	900	39,0	5	26	35	108	97	93	87	80	70	59	4.081,00	
IX878/05	1.025	45,0	5	30	40	135	121	116	109	100	88	74	4.682,00	
IX878/06	1.150	52,0	5	37	50	162	146	140	131	120	105	89	5.275,00	
IX878/07	1.275	58,0	5	44	60	189	170	163	152	140	123	103	5.855,00	
IX878/08	1.400	65,0	5	55	75	216	194	186	174	160	140	118	6.677,00	
IX878/09	1.525	71,0	5	55	75	243	218	209	196	180	158	133	7.288,00	
IX878/10	1.650	78,0	5	66	90	270	243	233	218	200	175	148	7.896,00	
IX878/11	1.775	84,0	5	66	90	297	267	256	239	220	193	162	8.513,00	
IX878/12	1.900	91,0	5	75	100	324	291	279	261	240	210	177	9.117,00	
IX878/13	2.025	97,0	5	75	100	351	315	302	283	260	228	192	9.765,00	
IX878/14	2.150	104,0	5	92	125	378	340	326	305	280	245	207	10.372,00	
IX878/15	2.275	110,0	5	92	125	405	364	349	326	300	263	221	10.978,00	
IX878/16	2.400	123,0	5	92	125	432	388	372	348	320	280	236	11.617,00	
IX878/17	2.525	123,0	5	110	150	459	412	395	370	340	298	251	12.227,00	
IX878/18	2.650	130,0	5	110	150	486	437	419	392	360	315	266	12.834,00	
IX878/19	2.775	136,0	5	110	150	513	461	442	413	380	333	280	13.440,00	

BOMBEO PARA POZO

Disponible en AISI 316 bajo demanda. Opción doble guardacable para arranque AET. P.V.P.: 65,00. Acoplamiento estriado por defecto, disponible acoplamiento chaveteado bajo demanda. Acoplamiento a motor: De 6" hasta 50 Hp. De 8" hasta 125 Hp. De 10" a partir de 150 Hp.



SEMIAXIALES INOX 8" SERIE IX



BOMBEO PARA POZO

IX890

MODELO	L mm	Peso Kg	DN Ø"	P ₂		CAUDAL								P.V.P. C. BOMBA	
						ALTURA DE CARGA EN METROS									
						m ³ /h	0	48	60	72	84	96	108		120
				kW	Hp	l/min	0	800	1000	1200	1400	1600	1800	2000	
IX890/01	525	19,0	5	7,5	10	27	24	23	22	20	18	16	13	2.274,00	
IX890/02	650	26,0	5	13	17,5	54	49	47	44	40	36	31	25	2.854,00	
IX890/03	775	32,0	5	22	30	81	73	70	65	60	54	47	38	3.467,00	
IX890/04	900	39,0	5	26	35	108	97	93	87	80	71	62	50	4.081,00	
IX890/05	1.025	45,0	5	37	50	135	121	116	109	101	89	78	63	4.683,00	
IX890/06	1.150	52,0	5	44	60	162	146	140	131	121	107	93	76	5.275,00	
IX890/07	1.275	58,0	5	44	60	189	170	163	152	141	125	109	88	5.979,00	
IX890/08	1.400	65,0	5	55	75	216	194	186	174	161	143	124	101	6.603,00	
IX890/09	1.525	71,0	5	66	90	243	218	209	196	181	161	140	114	7.204,00	
IX890/10	1.650	78,0	5	66	90	270	243	233	218	201	179	155	126	7.803,00	
IX890/11	1.775	84,0	5	75	100	297	267	256	239	221	197	171	139	8.412,00	
IX890/12	1.900	91,0	5	92	125	324	291	279	261	241	214	186	151	9.006,00	
IX890/13	2.025	97,0	5	92	125	351	315	302	283	262	232	202	164	9.645,00	
IX890/14	2.150	104,0	5	92	125	378	340	326	305	282	250	217	177	10.242,00	
IX890/15	2.275	110,0	5	110	150	405	364	349	326	302	268	233	189	10.840,00	
IX890/16	2.400	117,0	5	110	150	432	388	372	348	322	286	248	202	11.469,00	
IX890/17	2.525	123,0	5	110	150	459	412	395	370	342	304	264	215	12.071,00	

IX8102

MODELO	L mm	Peso Kg	DN Ø"	P ₂		CAUDAL								P.V.P. C. BOMBA		
						ALTURA DE CARGA EN METROS										
						m ³ /h	0	60	72	84	96	108	120		132	144
				kW	Hp	l/min	0	1000	1200	1400	1600	1800	2000	2200	2400	
IX8102/01	525	19,0	5	7,5	10	28	23	22	21	20	19	17	15	13	2.257,00	
IX8102/02	650	26,0	5	15	20	55	45	44	42	41	38	35	31	26	2.819,00	
IX8102/03	775	33,0	5	22	30	83	68	65	63	61	57	52	46	38	3.416,00	
IX8102/04	900	40,0	5	30	40	110	90	87	84	82	76	69	62	51	4.011,00	
IX8102/05	1.025	47,0	5	37	50	138	113	109	106	102	96	87	77	64	4.596,00	
IX8102/06	1.150	53,0	5	44	60	165	135	131	127	122	115	104	92	77	5.321,00	
IX8102/07	1.275	60,0	5	55	75	193	158	153	148	143	134	121	108	90	5.914,00	
IX8102/08	1.400	67,0	5	66	90	220	180	174	169	163	153	138	123	102	6.529,00	
IX8102/09	1.525	74,0	5	66	90	248	203	196	190	184	172	156	139	115	7.121,00	
IX8102/10	1.650	81,0	5	75	100	275	225	218	211	204	191	173	154	128	7.712,00	
IX8102/11	1.775	87,0	5	92	125	303	248	240	232	224	210	190	169	141	8.311,00	
IX8102/12	1.900	94,0	5	92	125	330	270	262	253	245	229	208	185	154	8.897,00	
IX8102/13	2.025	101,0	5	110	150	358	293	283	274	265	248	225	200	166	9.525,00	
IX8102/14	2.150	108,0	5	110	150	385	315	305	295	286	267	242	216	179	10.114,00	
IX8102/15	2.275	115,0	5	110	150	413	338	327	317	306	287	260	231	192	10.702,00	

Disponible en AISI 316 bajo demanda. Opción doble guardacable para arranque AET. P.V.P.: 65,00. Acoplamiento estriado por defecto, disponible acoplamiento chaveteado bajo demanda. Acoplamiento a motor: De 6" hasta 50 Hp. De 8" hasta 125 Hp. De 10" a partir de 150 Hp.



SEMIAXIALES INOX 8" SERIE IX



IX8124

MODELO	L mm	Peso Kg	DN Ø"	P ₂		CAUDAL										P.V.P. C. BOMBA
				kW	Hp	m ³ /h	l/min	0	72	84	96	108	120	132	144	
IX8124/01	525	20,0	5	9,2	12,5	27	23	22	21	20	19	18	16	15	12	2.265,00
IX8124/02	650	27,0	5	18,5	25	54	45	43	41	40	38	36	33	29	24	2.835,00
IX8124/03	775	34,0	5	26	35	81	68	65	62	59	57	54	49	44	36	3.441,00
IX8124/04	900	41,0	5	37	50	108	90	86	83	79	76	72	66	58	48	4.045,00
IX8124/05	1.025	48,0	5	44	60	135	113	108	104	99	95	90	82	73	60	4.832,00
IX8124/06	1.150	55,0	5	55	75	162	135	129	124	119	114	108	98	87	72	5.427,00
IX8124/07	1.275	62,0	5	66	90	189	158	151	145	139	133	126	115	102	84	6.038,00
IX8124/08	1.400	69,0	5	66	90	216	180	172	166	158	152	144	131	116	96	6.671,00
IX8124/09	1.525	76,0	5	75	100	243	203	194	186	178	171	162	148	131	108	7.280,00
IX8124/10	1.650	83,0	5	92	125	270	225	215	207	198	190	180	164	145	120	7.888,00
IX8124/11	1.775	90,0	5	92	125	297	248	237	228	218	209	198	180	160	132	8.504,00
IX8124/12	1.900	97,0	5	110	150	324	270	258	248	238	228	216	197	174	144	9.107,00
IX8124/13	2.025	104,0	5	110	150	351	293	280	269	257	247	234	213	189	156	9.754,00

IX8140

MODELO	L mm	Peso Kg	DN Ø"	P ₂		CAUDAL										P.V.P. C. BOMBA
				kW	Hp	m ³ /h	l/min	0	96	108	120	132	144	156	168	
IX8140/01	550	20,0	5	9,2	12,5	25	20	19	19	18	17	17	16	14	12	2.315,00
IX8140/02	700	28,0	5	18,5	25	50	40	39	38	36	35	33	31	28	24	2.936,00
IX8140/03	850	35,0	5	30	40	75	60	58	56	54	52	50	47	41	36	3.592,00
IX8140/04	1.000	43,0	5	37	50	100	80	77	75	72	70	66	62	55	48	4.248,00
IX8140/05	1.150	50,0	5	55	75	125	100	97	94	91	87	83	78	69	60	5.102,00
IX8140/06	1.300	58,0	5	55	75	150	120	116	113	109	104	100	93	83	72	5.760,00
IX8140/07	1.450	65,0	5	66	90	175	140	135	132	127	122	116	109	97	84	6.455,00
IX8140/08	1.600	73,0	5	75	100	200	160	154	150	145	139	133	124	110	96	7.104,00
IX8140/09	1.750	80,0	5	92	125	225	180	174	169	163	157	149	140	124	108	7.769,00
IX8140/10	1.900	88,0	5	110	150	250	200	193	188	181	174	166	155	138	120	8.431,00
IX8140/11	2.050	95,0	5	110	150	275	220	212	207	199	191	183	171	152	132	9.140,00
IX8140/12	2.200	103,0	5	110	150	300	240	232	226	217	209	199	186	166	144	9.798,00

Disponible en AISI 316 bajo demanda. Opción doble guardacable para arranque AET. P.V.P.: 65,00. Acoplamiento estriado por defecto, disponible acoplamiento chaveteado bajo demanda. Acoplamiento a motor: De 6" hasta 50 Hp. De 8" hasta 125 Hp. De 10" a partir de 150 Hp.

SEMIAXIALES INOX 10" SERIE IX

DESCRIPCIÓN

- Electrobombas sumergibles de 10" para pozo, con cuerpo difusor y rodete semiaxial en fundición de **acero inoxidable AISI 304** (bajo demanda en AISI 316) acoplable a motores sumergibles tipo **NEMA** hasta 10".
- Para evitar la fricción del impulsor contra el difusor se ha introducido en cada etapa un anillo de desgaste **EPDM**.

MATERIALES

- Cuerpo de aspiración e impulsión: **Acero INOX 304**
- Válvula de retención: **Acero INOX 304**
- Eje: **Acero INOX 304**
- Impulsores: **Acero INOX 304**
- Difusores: **Acero INOX 304**
- Anillo desgaste: **EPDM**

ÁREA DE TRABAJO

- Caudal máx.: **348 m³/h**
- Altura máx.: **375 mca**
- Rango de Potencia: **15,0 - 221,00 kW**
- Agua química y mecánicamente: **No agresiva**
- Contenido en sólido: **< 50 g/m³**
- Temperatura máx.: **Supeditada a tº máx. del motor.**



IX10200

MODELO	L mm	Peso Kg	DN Ø"	P ₂		CAUDAL								P.V.P. C. BOMBA
				kW	Hp	m³/h	l/min	0	108	132	156	180	204	
IX10200/01DR20	625	41,0	6	18,5	25	0	108	132	156	180	204	228	240	5.543,00
IX10200/01DR10	625	41,0	6	18,5	25	0	1800	2200	2600	3000	3400	3800	4000	5.543,00
IX10200/01	625	41,0	6	22	30	35	32	30	27	24	21	16	14	5.543,00
IX10200/02DR20	805	56,0	6	37	50	38	35	33	31	28	24	20	17	5.543,00
IX10200/02DR10	805	56,0	6	37	50	42	38	36	34	31	28	23	21	5.543,00
IX10200/02	805	56,0	6	44	60	69	63	60	55	49	41	33	28	7.139,00
IX10200/03DR20	985	72,0	6	55	75	76	70	66	61	55	48	40	35	7.139,00
IX10200/03DR10	985	72,0	6	55	75	83	77	73	68	62	55	47	41	7.139,00
IX10200/03	985	72,0	6	66	90	104	95	89	82	73	62	49	42	8.567,00
IX10200/04DR20	1.165	87,0	6	66	90	114	105	99	92	83	72	59	52	8.567,00
IX10200/04DR10	1.165	87,0	6	75	100	125	115	109	102	93	83	70	62	8.567,00
IX10200/04	1.165	87,0	6	92	125	138	126	119	110	98	82	66	56	10.276,00
IX10200/05DR20	1.345	103,0	6	92	125	152	140	132	122	110	98	82	70	10.276,00
IX10200/05DR10	1.345	103,0	6	92	125	166	154	146	136	124	110	94	82	10.276,00
IX10200/05	1.345	103,0	6	110	150	173	158	149	137	122	103	82	70	11.870,00
IX10200/06DR20	1.525	118,0	6	110	150	190	175	165	153	138	120	99	87	11.870,00
IX10200/06DR10	1.525	118,0	6	110	150	208	192	182	170	155	138	117	103	11.870,00
IX10200/06	1.525	118,0	6	129	175	208	190	179	164	146	124	98	84	13.466,00
IX10200/07DR20	1.705	134,0	6	110	150	228	210	198	184	166	144	119	104	13.466,00
IX10200/07DR10	1.705	134,0	6	129	175	250	230	218	204	186	166	140	124	13.466,00
IX10200/07	1.705	134,0	6	147	200	242	221	209	192	171	144	115	98	15.079,00
IX10200/08DR20	1.885	149,0	6	129	175	266	245	231	214	193	168	138	122	15.079,00
IX10200/08DR10	1.885	149,0	6	147	200	291	269	255	238	217	193	164	144	15.079,00
IX10200/08	1.885	149,0	6	165	225	277	253	238	219	195	165	131	112	16.714,00
IX10200/09DR20	2.065	165,0	6	147	200	304	280	264	245	221	192	158	139	16.714,00
IX10200/09DR10	2.065	165,0	6	165	225	333	307	291	272	248	221	187	165	16.714,00
IX10200/09	2.065	165,0	6	185	250	311	284	268	247	220	185	148	126	18.309,00
						342	315	297	275	248	216	178	157	18.309,00
						374	346	328	306	279	248	211	185	18.309,00

Disponibile en AISI 316 bajo demanda. Opción doble guardacable para arranque AET. P.V.P.: 65,00. Acoplamiento estriado por defecto, disponible acoplamiento chaveteado bajo demanda. Acoplamiento a motor: De 6" hasta 50 Hp. De 8" hasta 125 Hp. De 10" a partir de 150 Hp.

SEMIAXIALES INOX 10" SERIE IX



IX10220

MODELO	L mm	Peso Kg	DN Ø"	P ₂		CAUDAL								P.V.P. C C. BOMBA
				kW	Hp	0	132	156	180	204	228	252	276	
ALTURA DE CARGA EN METROS														
IX10220/01DR20	625	41	6	18,5	25	37	31	29	27	25	23	19	16	5.532,00
IX10220/01DR10	625	41	6	22	30	40	34	33	31	29	26	23	20	5.532,00
IX10220/01	625	41	6	22	30	44	38	36	34	32	30	26	23	5.532,00
IX10220/02DR20	805	56	6	37	50	74	62	58	54	50	45	38	32	7.116,00
IX10220/02DR10	805	56	6	44	60	81	68	65	61	57	52	46	39	7.116,00
IX10220/02	805	56	6	44	60	88	75	72	68	64	59	53	46	7.116,00
IX10220/03DR20	985	72	6	55	75	110	93	87	81	75	68	57	48	8.535,00
IX10220/03DR10	985	72	6	66	90	121	102	98	92	86	78	68	59	8.535,00
IX10220/03	985	72	6	75	100	131	113	108	102	96	89	79	69	8.535,00
IX10220/04DR20	1.165	87	6	75	100	147	124	116	108	100	90	76	64	10.233,00
IX10220/04DR10	1.165	87	6	92	125	162	136	130	122	114	104	91	78	10.233,00
IX10220/04	1.165	87	6	92	125	175	150	144	136	128	118	106	92	10.233,00
IX10220/05DR20	1.345	103	6	92	125	184	155	145	135	125	113	95	80	11.817,00
IX10220/05DR10	1.345	103	6	110	150	202	170	163	153	143	130	114	98	11.817,00
IX10220/05	1.345	103	6	129	175	219	188	180	170	160	148	132	115	11.817,00
IX10220/06DR20	1.525	118	6	110	150	221	186	174	162	150	136	114	96	13.401,00
IX10220/06DR10	1.525	118	6	129	175	242	204	196	184	172	156	137	118	13.401,00
IX10220/06	1.525	118	6	147	200	263	226	216	204	192	178	158	138	13.401,00
IX10220/07DR20	1.705	134	6	129	175	258	217	203	189	175	158	133	112	15.004,00
IX10220/07DR10	1.705	134	6	147	200	283	238	228	214	200	182	160	137	15.004,00
IX10220/07	1.705	134	6	165	225	307	263	252	238	224	207	185	161	15.004,00

IX10240

MODELO	L mm	Peso Kg	DN Ø"	P ₂		CAUDAL								P.V.P. C C. BOMBA		
				kW	Hp	0	144	168	192	216	240	264	288		300	312
ALTURA DE CARGA EN METROS																
IX10240/01DR20	625	41,0	6	18,5	25	31	29	28	27	25	23	21	18	5.352,00		
IX10240/01DR10	625	41,0	6	22	30	36	33	32	31	29	27	24	22	5.352,00		
IX10240/01	625	41,0	6	30	40	44	37	35	34	32	30	28	26	5.352,00		
IX10240/02DR20	805	56,0	6	37	50	62	58	56	54	50	46	42	36	6.891,00		
IX10240/02DR10	805	56,0	6	44	60	72	66	64	62	58	54	48	44	6.891,00		
IX10240/02	805	56,0	6	55	75	88	73	69	67	64	59	56	52	6.891,00		
IX10240/03DR20	985	72,0	6	55	75	94	88	85	81	76	70	63	53	8.399,00		
IX10240/03DR10	985	72,0	6	66	90	107	100	97	93	86	80	73	65	8.399,00		
IX10240/03	985	72,0	6	92	125	132	110	104	101	96	89	83	75	8.399,00		
IX10240/04DR20	1.165	87,0	6	75	100	125	117	113	108	101	93	84	71	10.052,00		
IX10240/04DR10	1.165	87,0	6	92	125	143	133	129	124	115	107	97	87	10.052,00		
IX10240/04	1.165	87,0	6	110	150	176	146	138	134	128	118	111	104	10.052,00		
IX10240/05DR20	1.345	103,0	6	92	125	156	146	141	135	126	116	105	89	11.591,00		
IX10240/05DR10	1.345	103,0	6	110	150	179	166	161	155	144	134	121	109	11.591,00		
IX10240/05	1.345	103,0	6	147	200	220	183	173	168	160	148	139	130	11.591,00		
IX10240/06DR20	1.525	118,0	6	110	150	187	175	169	162	151	139	126	107	13.129,00		
IX10240/06DR10	1.525	118,0	6	147	200	215	199	193	186	173	161	145	131	13.129,00		
IX10240/06	1.525	118,0	6	165	225	264	220	208	202	192	178	167	156	13.129,00		
IX10240/07DR20	1.705	134,0	6	129	175	218	204	197	189	176	162	147	125	14.687,00		
IX10240/07DR10	1.705	134,0	6	165	225	251	232	225	217	202	188	169	153	14.687,00		
IX10240/07	1.705	134,0	6	220	300	308	256	242	235	224	207	195	182	14.687,00		

Disponible en AISI 316 bajo demanda. Opción doble guardacable para arranque AET. P.V.P.: 65,00. Acoplamiento estriado por defecto, disponible acoplamiento chaveteado bajo demanda. Acoplamiento a motor: De 6" hasta 50 Hp. De 8" hasta 125 Hp. De 10" a partir de 150 Hp.



IX10280

		CAUDAL							
m ³ /h	0	180	204	228	252	276	300	324	348
l/min	0	3000	3400	3800	4200	4600	5000	5400	5800

MODELO	L	Peso	DN	P ₂		ALTURA DE CARGA EN METROS								P.V.P. C. BOMBA	
	mm	Kg	Ø"	kW	Hp	36	29	28	26	25	23	21	19		16
IX10280/01DR20	625	41,0	6	26	35	36	29	28	26	25	23	21	19	16	5.247,00
IX10280/01DR10	625	41,0	6	30	40	41	33	32	31	29	27	26	24	21	5.247,00
IX10280/01	625	41,0	6	44	60	45	38	37	35	34	32	30	28	25	5.247,00
IX10280/02DR20	805	56,0	6	55	75	72	58	56	52	50	46	42	39	32	6.939,00
IX10280/02DR10	805	56,0	6	66	90	82	67	65	62	59	55	52	48	42	6.939,00
IX10280/02	805	56,0	6	66	90	90	75	73	70	67	63	60	56	50	6.939,00
IX10280/03DR20	985	72,0	6	75	100	109	86	83	79	74	68	64	58	49	8.467,00
IX10280/03DR10	985	72,0	6	92	125	122	100	97	92	88	82	77	72	62	8.467,00
IX10280/03	985	72,0	6	110	150	135	113	110	105	101	95	90	85	75	8.467,00
IX10280/04DR20	1.165	87,0	6	110	150	145	115	111	105	99	91	85	78	65	10.142,00
IX10280/04DR10	1.165	87,0	6	129	175	163	134	130	123	118	109	103	96	83	10.142,00
IX10280/04	1.165	87,0	6	129	175	180	150	146	140	134	126	120	113	100	10.142,00
IX10280/05DR20	1.345	103,0	6	129	175	181	144	139	131	124	114	106	97	81	11.704,00
IX10280/05DR10	1.345	103,0	6	147	200	204	167	162	154	147	137	129	120	104	11.704,00
IX10280/05	1.345	103,0	6	165	225	225	188	183	175	168	158	150	141	125	11.704,00
IX10280/06DR20	1.525	118,0	6	147	200	217	173	167	157	149	136	127	116	97	13.265,00
IX10280/06DR10	1.525	118,0	6	185	250	245	200	194	185	176	164	155	144	125	13.265,00
IX10280/06	1.525	118,0	6	220	300	270	226	220	210	202	189	180	169	150	13.265,00
IX10280/07DR20	1.705	134,0	6	185	250	253	202	195	183	174	159	148	136	113	14.846,00
IX10280/07DR10	1.705	134,0	6	220	300	286	234	227	216	206	191	181	168	146	14.846,00
IX10280/07	1.705	134,0	6	250	340	315	263	256	245	235	221	210	197	175	14.846,00

BOMBEO PARA POZO



IMPULSORES Y DIFUSORES EN
ACERO INOX 304

Disponibles en AISI 316 bajo demanda. Opción **doble guardacable** para arranque AET. P.V.P.: 65,00. **Acoplamiento estriado** por defecto, disponible acoplamiento chaveteado bajo demanda. **Acoplamiento a motor**: De 6" hasta 50 Hp. De 8" hasta 125 Hp. De 10" a partir de 150 Hp.

DESCRIPCIÓN

- Electrobombas sumergibles de 12" para pozo, con cuerpo difusor y rodete semiaxial en fundición de **acero inoxidable AISI 304** (bajo demanda en AISI 316) acoplable a motores sumergibles tipo **NEMA** hasta 10".
- Para evitar la fricción del impulsor contra el difusor se ha introducido en cada etapa un anillo de desgaste **EPDM**.

MATERIALES

- Cuerpo de aspiración e impulsión: **Acero INOX 304**
- Válvula de retención: **Acero INOX 304**
- Eje: **Acero INOX 304**
- Impulsores: **Acero INOX 304**
- Difusores: **Acero INOX 304**
- Anillo desgaste: **EPDM**

ÁREA DE TRABAJO

- Caudal máx.: **348 m³/h**
- Altura máx.: **375 mca**
- Rango de Potencia: **15,0 - 221,00 kW**
- Agua química y mecánicamente: **No agresiva**
- Contenido en sólido: **< 50 g/m³**
- Temperatura máx.: **Supeditada a t° máx. del motor.**



IX12370

MODELO	L mm	Peso Kg	DN mm	P ₂		CAUDAL										P.V.P. C. BOMBA							
				kW	Hp	m³/h	0	180	210	240	270	300	330	360	390		420	l/min	0	3000	3500	4000	4500
IX12370/01DR35	770	79	200	37	50	41	38	37	37	35	33	32	29	12.285,00									
IX12370/01DR26	770	79	200	44	60	46	45	44	43	42	39	38	36	34	12.285,00								
IX12370/01DR20	770	79	200	55	75	49	48	47	47	45	44	42	40	38	34	12.285,00							
IX12370/01DR10	770	79	200	55	75	55	52	52	51	50	48	47	44	42	40	12.285,00							
IX12370/01	770	79	200	66	90	62	56	55	55	53	52	52	50	47	42	12.285,00							
IX12370/02DR35	1.000	104	200	75	100	82	76	74	73	70	66	63	57	15.981,00									
IX12370/02DR26	1.000	104	200	92	125	92	89	88	86	84	78	75	72	68	15.981,00								
IX12370/02DR20	1.000	104	200	110	150	98	95	94	93	90	87	84	80	75	68	15.981,00							
IX12370/02DR10	1.000	104	200	110	150	110	104	103	101	99	96	93	88	84	80	15.981,00							
IX12370/02	1.000	104	200	129	175	124	112	110	109	106	104	103	100	93	84	15.981,00							
IX12370/03DR35	1.230	129	200	110	150	123	114	111	110	105	99	95	86	19.767,00									
IX12370/03DR26	1.230	129	200	129	175	138	134	132	129	126	117	113	108	102	19.767,00								
IX12370/03DR20	1.230	129	200	147	200	147	143	141	140	135	131	126	120	113	102	19.767,00							
IX12370/03DR10	1.230	129	200	165	225	165	156	155	152	149	144	140	132	126	120	19.767,00							
IX12370/03	1.230	129	200	220	300	186	168	165	164	159	156	155	150	140	126	19.767,00							
IX12370/04DR35	1.460	154	200	147	200	164	152	148	146	140	132	126	114	23.740,00									
IX12370/04DR26	1.460	154	200	185	250	184	178	176	172	168	156	155	144	136	23.740,00								
IX12370/04DR20	1.460	154	200	220	300	196	190	188	186	180	174	168	160	150	136	23.740,00							
IX12370/04DR10	1.460	154	200	220	300	220	208	206	202	198	192	186	176	168	160	23.740,00							
IX12370/04	1.460	154	200	250	340	248	224	220	218	212	208	206	200	186	168	23.740,00							
IX12370/05DR35	1.690	179	200	185	250	205	190	185	183	175	165	158	143	27.454,00									
IX12370/05DR26	1.690	179	200	220	300	230	223	220	215	210	195	188	180	170	27.454,00								
IX12370/05DR20	1.690	179	200	250	340	245	238	235	233	225	218	210	200	188	170	27.454,00							
IX12370/05DR10	1.690	179	200	300	408	275	260	258	253	248	240	233	220	210	200	27.454,00							
IX12370/05	1.690	179	200	350	475	310	280	275	273	265	260	258	250	233	210	27.454,00							

Disponibile en AISI 316 bajo demanda. Opción **doble guardacable** para arranque AET. P.V.P.: 65,00. **Acoplamiento estriado** por defecto, disponible acoplamiento chaveteado bajo demanda. **Acoplamiento a motor:** De 6" hasta 50 Hp. De 8" hasta 125 Hp. De 10" a partir de 150 Hp.

IX12440

		CAUDAL											
m³/h		0	240	270	300	330	360	390	420	450	480	510	540
l/min		0	4000	4500	5000	5500	6000	6500	7000	7500	8000	8500	9000

MODELO	L	Peso	DN	P ₂		ALTURA DE CARGA EN METROS												P.V.P. C. BOMBA																																																																																																																																																																																																																																																																					
	mm	Kg	mm	kW	Hp	43	39	38	36	34	32	30	27	24	47	44	43	41	39	37	35	33	30	26	22	53	50	48	46	44	42	40	38	36	32	28	58	54	52	50	48	46	44	42	40	37	31	27	61	57	54	53	52	50	48	46	44	41	39	32	86	78	76	72	68	64	60	54	48	94	88	86	82	77	73	69	65	59	52	44	106	100	96	92	88	84	80	76	71	64	56	116	108	104	100	96	92	88	84	80	73	62	54	122	114	108	106	104	100	96	92	89	82	78	64	129	117	113	108	102	96	89	81	72	141	132	129	123	116	110	104	98	89	78	66	159	150	144	138	132	126	120	114	107	96	84	174	162	156	150	144	138	132	126	120	110	93	81	183	171	162	159	156	150	144	138	134	123	117	96	172	156	150	144	136	128	118	108	96	188	176	172	164	154	146	138	130	118	104	88	212	200	192	184	176	168	160	152	142	128	112	232	216	208	200	192	184	176	168	160	146	124	108	244	228	216	212	208	200	192	184	178	164	156	128	215	195	188	180	170	160	148	135	120	235	220	215	205	193	183	173	163	148	130	110	265	250	240	230	220	210	200	190	178	160	140	290	270	260	250	240	230	220	210	200	183	155	135	305	285	270	265	260	250	240	230	223	205	195
IX12440/01DR30	770	79	200	37	50													12.204,00																																																																																																																																																																																																																																																																					
IX12440/01DR20	770	79	200	44	60													12.204,00																																																																																																																																																																																																																																																																					
IX12440/01DR10	770	79	200	55	75													12.204,00																																																																																																																																																																																																																																																																					
IX12440/01	770	79	200	66	90													12.204,00																																																																																																																																																																																																																																																																					
IX12440/01A	770	79	200	66	90													12.204,00																																																																																																																																																																																																																																																																					
IX12440/02DR30	1.000	104	200	75	100													15.822,00																																																																																																																																																																																																																																																																					
IX12440/02DR20	1.000	104	200	92	125													15.822,00																																																																																																																																																																																																																																																																					
IX12440/02DR10	1.000	104	200	110	150													15.822,00																																																																																																																																																																																																																																																																					
IX12440/02	1.000	104	200	129	175													15.822,00																																																																																																																																																																																																																																																																					
IX12440/02A	1.000	104	200	147	200													15.822,00																																																																																																																																																																																																																																																																					
IX12440/03DR30	1.230	129	200	129	175													19.532,00																																																																																																																																																																																																																																																																					
IX12440/03DR20	1.230	129	200	147	200													19.532,00																																																																																																																																																																																																																																																																					
IX12440/03DR10	1.230	129	200	165	225													19.532,00																																																																																																																																																																																																																																																																					
IX12440/03	1.230	129	200	185	250													19.532,00																																																																																																																																																																																																																																																																					
IX12440/03A	1.230	129	200	220	300													19.532,00																																																																																																																																																																																																																																																																					
IX12440/04DR30	1.460	154	200	165	224													23.405,00																																																																																																																																																																																																																																																																					
IX12440/04DR20	1.460	154	200	185	250													23.405,00																																																																																																																																																																																																																																																																					
IX12440/04DR10	1.460	154	200	220	300													23.405,00																																																																																																																																																																																																																																																																					
IX12440/04	1.460	154	200	250	340													23.405,00																																																																																																																																																																																																																																																																					
IX12440/04A	1.460	154	200	300	408													23.405,00																																																																																																																																																																																																																																																																					
IX12440/05DR30	1.690	179	200	220	300													27.036,00																																																																																																																																																																																																																																																																					
IX12440/05DR20	1.690	179	200	250	340													27.036,00																																																																																																																																																																																																																																																																					
IX12440/05DR10	1.690	179	200	300	408													27.036,00																																																																																																																																																																																																																																																																					
IX12440/05	1.690	179	200	300	408													27.036,00																																																																																																																																																																																																																																																																					
IX12440/05A	1.690	179	200	350	475													27.036,00																																																																																																																																																																																																																																																																					

Disponibles en AISI 316 bajo demanda. Opción doble guardacable para arranque AET. P.V.P.: 65,00. Acoplamiento estriado por defecto, disponible acoplamiento chaveteado bajo demanda. Acoplamiento a motor: De 6" hasta 50 Hp. De 8" hasta 125 Hp. De 10" a partir de 150 Hp.

BOMBEO PARA POZO



DESCRIPCIÓN

- Electrobombas sumergibles radiales multicelulares de 4" para pozos, acoplable a motores sumergibles tipo NEMA de gran fiabilidad y rendimiento gracias a la utilización de materiales de primera calidad.
- **Elevada resistencia al desgaste de los impulsores y difusores**, protegidos en los puntos de mayor tensión en acero inoxidable. Incorpora un patín especial que permite atenuar la fricción en los casos de terrenos arenosos, así como soportes intermedios y casquillos en INOX en las de mayor longitud.

MATERIALES

- Cuerpo de aspiración e impulsión: **Aleación latón alta resistencia**
- Válvula de retención: **De bola de goma***
- Camisa: **Acero inoxidable**
- Eje: **Acero inoxidable**
- Impulsores y difusores: **Termoplástico reforzado con fibra de vidrio (Excepto modelos 4H36 y 4N41)**

ÁREA DE TRABAJO

- Caudal máx.: **22,8 m³/h**
- Altura máx.: **375 mca**
- Rango de Potencia: **0,37 - 7,50 kW**
- Agua química y mecánicamente: **No agresiva**
- Contenido en sólido: **< 150 g/m³**
- Temperatura máx. del líquido: **30°C**
- Tiempo máx. funcionamiento a llave cerrada: **2-3 min.**



4B

MODELO	L mm	Peso Kg	DN Ø"	P ₂		CAUDAL										P.V.P. C. BOMBA
				kW	Hp	m³/h	l/min	0	0,6	0,9	1,1	1,4	1,7	1,9	2,2	
4B54	1.807	13,0	1¼	2,2	3,0	282	272	258	245	217	185	155	126	97	45	586,00

4L

MODELO	L mm	Peso Kg	DN Ø"	P ₂		CAUDAL										P.V.P. C. BOMBA
				kW	Hp	m³/h	l/min	0	0,6	1,2	1,8	2,1	2,4	2,7	3	
4L07	443	5,0	1¼	0,37	0,5	50	49	46	42	39	36	32	28	20	11	219,00
4L39	1.358	12,0	1¼	2,2	3,0	252	248	230	202	186	171	150	128	88	50	456,00
4L50	1.700	13,5	1¼	3,0	4,0	320	300	272	240	219	195	172	145	104	62	575,00

4S

MODELO	L mm	Peso Kg	DN Ø"	P ₂		CAUDAL										P.V.P. C. BOMBA
				kW	Hp	m³/h	l/min	0	0,6	1,2	1,8	2,4	3,0	3,6	4,2	
4S15	660	6,0	1¼	1,10	1,5	110	108	106	100	92	82	70	58	43	28	261,00
4S39	1.358	12,0	1¼	3,0	4,0	278	270	258	240	220	192	160	127	90	52	456,00

4H

MODELO	L mm	Peso Kg	DN Ø"	P ₂		CAUDAL										P.V.P. C. BOMBA
				kW	Hp	m³/h	l/min	0	1,2	1,8	2,4	3	3,6	4,2	4,8	
4H20	939	8,0	1¼	2,0	3,0	140	132	128	125	118	112	107	100	82	60	354,00
4H26	1.183	10,0	1¼	3,0	4,0	185	180	173	168	162	155	146	137	110	78	390,00

HIDRÁULICAS RADIALES 4"

4N

MODELO	L mm	Peso Kg	DN Ø"	P ₂		CAUDAL										P.V.P. C. BOMBA
				kW	Hp	m ³ /h	l/min	0	4,8	6	7,2	7,5	8,1	8,7	9,3	
4N41	2.324	17,0	2	5,5	7,5	245	200	171	135	126	110	93	73	40	23	696,00

4F

MODELO	L mm	Peso Kg	DN Ø"	P ₂		CAUDAL										P.V.P. C. BOMBA
				kW	Hp	m ³ /h	l/min	0	4,8	6	9	10,5	12	15	18	
4F18	1.835	14,0	2	4,0	5,5	101	92	90	76	69	62	49	32	13	5	513,00
4F24	2.255	17,0	2	5,5	7,5	136	125	120	103	92	85	68	46	17	6	619,00
4F35	3.185	22,0	2	7,5	10	186	175	169	147	134	119	95	66	26	7	822,00



DESCRIPCIÓN

- Electrobombas sumergibles radiales multicelulares de 6" para pozos, acoplable a motores sumergibles tipo **NEMA** de gran fiabilidad y rendimiento gracias a la utilización de materiales de primera calidad.
- **Elevada resistencia al desgaste de los impulsores y difusores**, protegidos en los puntos de mayor tensión en acero inoxidable. Incorpora un patín especial que permite atenuar la fricción en los casos de terrenos arenosos, así como soportes intermedios y casquillos en INOX en las de mayor longitud.



MATERIALES

- Cuerpo de aspiración e impulsión: **Aleación latón alta resistencia**
- Válvula de retención: **De clapeta INOX**
- Camisa: **Acero inoxidable**
- Eje: **Acero inoxidable**
- Impulsores y difusores: **Termoplástico reforzado con fibra de vidrio**

ÁREA DE TRABAJO

- Caudal máx.: **48 m³/h**
- Altura máx.: **602 mca**
- Rango de Potencia: **4,00 - 37,00 kW**
- Agua química y mecánicamente: **No agresiva**
- Contenido en sólido: **< 150 g/m³**
- Temperatura máx. del líquido: **30°C**
- Tiempo máx. funcionamiento a llave cerrada: **2-3 min.**



MODELO	L mm	Peso Kg	DN Ø"	P ₂		CAUDAL							P.V.P. C. BOMBA
						ALTURA DE CARGA EN METROS							
						m ³ /h	l/min	0	3	4,5	6	7,5	
6D112 *	823	18,0	3	4,0	5,5	138	126	114	106	87	77	38	766,00
6D117 *	1.024	21,0	3	5,5	7,5	190	178	160	150	126	109	54	843,00
6D122 *	1.275	26,0	3	7,5	10	253	230	210	194	164	141	70	965,00
6D139	1.960	36,0	3	13	17,5	445	406	360	324	270	227	120	1.473,00
6D145	2.259	44,0	3	15	20	530	492	445	410	345	288	143	1.651,00

(*) Suplemento por bomba de 6" con acople a 4": 41,20€
Opción doble pasacable para arranque AET: 28,00€

MODELO	L mm	Peso Kg	DN Ø"	P ₂		CAUDAL								P.V.P. C. BOMBA	
						ALTURA DE CARGA EN METROS									
						m ³ /h	l/min	0	3	6	9	12	15		18
6Z113 *	931	20,0	3	7,5	10	175	170	165	160	140	122	88	60	20	769,20
6Z140	2.278	41,0	3	22	30	520	510	490	460	390	330	260	160	50	1.482,00

(*) Suplemento por bomba de 6" con acople a 4": 41,20€
Opción doble pasacable para arranque AET: 28,00€

MODELO	L mm	Peso Kg	DN Ø"	P ₂		CAUDAL									P.V.P. C. BOMBA
						ALTURA DE CARGA EN METROS									
						m ³ /h	l/min	0	6	12	15	18	21	24	
6X106	612	15,0	3	4,0	5,5	90	84	74	70	64	57	47	36	24	636,00
6X125	1.535	29,0	3	18,5	25	350	342	324	310	286	260	220	178	126	1.105,00
6X140	2.280	41,0	3	37	50	602	590	531	490	432	375	311	246	176	1.587,00

(*) Suplemento por bomba de 6" con acople a 4": 41,20€
Opción doble pasacable para arranque AET: 28,00€

6G

MODELO	L mm	Peso Kg	DN Ø"	P ₂		CAUDAL									P.V.P. C. BOMBA						
				kW	Hp	m ³ /h	0	12	18	24	27	30	33	36		39	l/min	0	200	300	400
6G115	1.357	27,0	3	15	20	218	195	175	145	135	120	97	70	45	961,00						
6G118	1.554	29,0	3	18	25	265	245	230	188	170	150	115	84	54	1.057,00						
6G122	1.813	33,0	3	22	30	321	296	269	222	198	167	133	96	60	1.222,00						

(*) Suplemento por bomba de 6" con acople a 4": **41,20€**
Opción doble pasacable para arranque AET.: **28,00€**

6V

MODELO	L mm	Peso Kg	DN Ø"	P ₂		CAUDAL									P.V.P. C. BOMBA						
				kW	Hp	m ³ /h	0	15	18	21	24	30	36	42		48	l/min	0	250	300	350
6V103	530	14,0	3	4,0	5,5	48	42	40	38	35	31	25	14	4	610,00						
6V106*	725	17,0	3	7,5	10	95	77	74	72	68	60	47	30	12	678,00						
6V109	919	19,0	3	11	15	145	123	118	113	105	89	69	45	20	745,00						
6V112	1.112	23,0	3	15	20	180	159	153	147	137	118	96	65	30	868,00						
6V115	1.357	26,0	3	18,5	25	220	197	186	175	166	145	118	81	40	961,00						

(*) Suplemento por bomba de 6" con acople a 4": **41,20€**
Opción doble pasacable para arranque AET.: **28,00€**

BOMBEO PARA POZO



VISITE NUESTRA WEB
PARA OBTENER MÁS
INFORMACIÓN TÉCNICA
DE NUESTROS PRODUCTOS



Capture el código QR para acceder a nuestra web.



MOTORES SUMERGIBLES PARA POZO



MOTORES DE 4" SERIE PMO

DESCRIPCIÓN

- Motores sumergibles de 4" para hidráulicas con acoplamiento **NEMA**.
- Refrigeración mediante **baño de aceite**.



MATERIALES

- Carcasa: **Acero INOX 304**
- Eje: **Acero INOX 304**
- Cierre mecánico: **Cer/SiC**

ÁREA DE TRABAJO

- Temperatura máx. del agua: **30°C**
- Velocidad mín. de refrigeración: **0,08 m/s**
- Profundidad máx. de inmersión: **150 m**
- Arranques máx. por hora: **60**
- Grado de protección: **IP68**
- Aislamiento clase: **B**

BAÑO DE ACEITE

MODELO	P ₁		COND.		I (A)				COS φ		Nm		F. AXIAL		PESO (Kg)		P.V.P		B
	kW	Hp	μF	1~230V	3~400V	230V	400V	230V	400V	R.P.M.	N	MONOF.	TRIF.	MONOF.	TRIF.				
PMO005	0,37	0,5	25	3,2	-	59,4	-	0,87	-	2.840	1500	9,0	-	161,00	-				
PMO007	0,55	0,75	30	4,5	-	63,7	-	0,88	-	2.840	1500	9,8	-	175,00	163,00				
PMO010	0,75	1,0	40	6,4	2	63	79,4	0,84	0,71	2.840	1500	11,0	9,3	193,00	181,00				
PMO015	1,1	1,5	45	7,8	3,1	70,3	73,4	0,91	0,73	2.840	2500	13,0	11,4	230,00	221,00				
PMO020	1,5	2,0	65	10,8	4,5	68,9	75,4	0,92	0,67	2.840	2500	15,0	12,0	270,00	253,00				
PMO030	2,2	3,0	75	13,9	5,5	77,5	77,2	0,93	0,79	2.840	2500	20,5	14,5	343,00	277,00				
PMO040	3,0	4,0	-	-	7,4	-	78,3	-	0,78	2.840	4400	-	18,5	-	382,00				
PMO055	4,0	5,5	-	-	10	-	78,3	-	0,78	2.840	5000	-	21,5	-	428,00				
PMO075	5,5	7,5	-	-	13,8	-	78,0	-	0,77	2.840	5000	-	25,5	-	655,00				
PMO100	7,5	10	-	-	18,3	-	78,7	-	0,79	2.840	5000	-	31,5	-	835,00				

MOTORES DE 4" Sumoto

DESCRIPCIÓN

- Motores sumergibles de 4" para hidráulicas con acoplamiento **NEMA**.
- Refrigeración del bobinado mediante **baño de aceite/agua**.



MATERIALES

- Envoltente exterior y base: **Acero INOX 304**
- Eje: **Acero INOX 304**
- Cierre mecánico: **Graf/Cer**
- Juntas: **NBR**

ÁREA DE TRABAJO

- Temperatura máx. del agua: **30°C**
- Velocidad mín. de refrigeración: **0,08 m/s**
- Profundidad máx. de inmersión: **150 m**
- Arranques máx. por hora: **30**
- Grado de protección: **IP68 (Aceite), IP68 (Agua)**
- Aislamiento clase: **B**

BAÑO DE ACEITE

MODELO	P ₁		COND.*		I (A)			COS φ		R.P.M.		F.AXIAL	L	PESO	P.V.P		B
	kW	HP	μF	1~230V	3~230V	3~400V	230V	400V	230V	400V	N	mm	Kg	MONOF.	TRIF.		
MS4005	0,37	0,5	20	3,6	2,5	1,6	0,94	0,72	2.860	2.840	1.500	325	7,0	270,00	263,00		
MS4007	0,55	0,75	25	4,5	3,3	2,0	0,94	0,75	2.855	2.830	1.500	325	7,6	285,00	270,00		
MS4010	0,75	1,0	35	6,0	4,2	2,6	0,96	0,74	2.855	2.830	1.500	350	8,7	300,00	281,00		
MS4015	1,1	1,5	40	8,2	5,6	3,4	0,97	0,74	2.855	2.820	1.500	385	10,4	319,00	319,00		
MS4020	1,5	2,0	50	11,0	7,6	4,6	0,98	0,72	2.855	2.820	1.500	420	12,0	368,00	349,00		
MS4030	2,2	3,0	70	14,8	10,4	6,2	0,96	0,76	2.820	2.820	2.500	470	14,2	506,00	435,00		
MS4040	3,0	4,0	-	-	13,7	8,0	-	0,80	-	2.860	5.000	550	19,0	-	653,00		
MS4055	4,0	5,5	-	-	17,4	10,2	-	0,82	-	2.840	5.000	580	20,5	-	776,00		
MS4075	5,5	7,5	-	-	24,4	14,4	-	0,83	-	2.830	5.000	650	22,4	-	878,00		
MS4100	7,5	10	-	-	33,0	19,5	-	0,78	-	2.820	7.500	810	27,0	-	1.211,00		

BAÑO DE AGUA

MODELO	P ₂		COND.*		I (A)			COS. φ		R.P.M.		F. AXIAL	L	PESO	P.V.P		B
	kW	Hp	μF	1~230V	3~230V	3~400V	230V	400V	230V	400V	N	mm	Kg	MONOF.	TRIF.		
MSW4005	0,37	0,5	16	3,4	2,1	1,2	0,91	0,73	2.850	2.840	1.500	235	6,0	387,60	381,00		
MSW4007	0,55	0,75	20	4,4	2,9	1,7	0,92	0,73	2.855	2.840	1.500	250	8,0	404,30	394,30		
MSW4010	0,75	1,0	30	5,9	3,8	2,2	0,94	0,75	2.860	2.840	1.500	265	9,0	434,40	407,70		
MSW4015	1,1	1,5	40	7,8	5,2	3,0	0,94	0,76	2.850	2.840	3.000	295	11,0	484,50	467,80		
MSW4020	1,5	2,0	50	10,2	6,9	4,0	0,95	0,78	2.850	2.830	3.000	340	12,0	574,80	528,00		
MSW4030	2,2	3,0	70	15,0	9,7	5,6	0,94	0,79	2.840	2.830	3.000	375	14,0	738,50	651,60		
MSW4040	3,0	4,0	-	-	13,0	7,5	-	0,79	-	2.830	6.500	480	18,0	-	1.002,50		
MSW4055	4,0	5,5	-	-	17,5	10,1	-	0,77	-	2.840	6.500	555	24,0	-	1.106,10		
MSW4075	5,5	7,5	-	-	23,6	13,6	-	0,80	-	2.840	6.500	675	30,0	-	1.320,00		

*Condensador no incluido.

MOTOR DE 4" Y 6" SÍNCRONO DE IMANES PERMANENTES

DESCRIPCIÓN

- Motores sumergibles síncrono de imanes permanentes (PSMS) de 4" y 6" para hidráulicas con acoplamiento **NEMA**.
- Su tecnología de imanes permanentes **reduce el consumo eléctrico y mejora el par motor** permitiendo una operación **más eficiente**.



MATERIALES

- Carcasa: **Acero INOX 304**
- Eje: **Acero INOX 304**
- Cierre mecánico: **Graf/Cer**
- Devanado: **Cobre esmaltado**
- Rodamiento de alta calidad

ÁREA DE TRABAJO

- Temperatura máx. del líquido: **35°C**
- Profundidad máx. de inmersión: **50 m**
- Arranques máximos por hora: **30**
- Grado de protección: **IP68**
- Aislamiento clase: **F**

MODELO	DN		P ₂		I (A)			COS φ	Nm	L	PESO	P.V.P
	ø"	kW	HP	3~230V	3~400V	400V	R.P.M.	mm	Kg	TRIF.		
MIP-1500	4	1,5	2,0	7,0	-	0,93	4.000	227	7,0	432,00		
MIP-2200	4	2,2	3,0	10,0	-	0,93	4.000	305	7,1	460,00		
MIP-3700	4	3,7	5,0	-	9,0	0,93	4.000	318	7,5	584,00		
MIP-5500	4	5,5	7,5	-	13,0	0,93	4.000	497	8,0	695,00		
MIP-7500	4	7,5	10	-	17,0	0,93	4.000	597	8,7	798,00		
MIP-9200	6	9,2	12,5	-	22,0	0,93	3.600	540	50,0	1.003,00		
MIP-11000	6	11	15	-	25,0	0,93	3.600	690	60,0	1.207,00		
MIP-15000	6	15	20	-	35,0	0,93	3.600	780	70,0	1.395,00		

⚠ AVISO: Antes de sumergir un motor de imanes permanentes, es crucial configurar el variador de frecuencia en seco para asegurar la operatividad y protección del motor bajo el agua.

MOTORES DE 6" REBOBINABLES INOX SERIE MS16

DESCRIPCIÓN

- Motores sumergibles de 6" para hidráulicas con acoplamiento **NEMA** rebobinables.
- Fabricados en acero **INOX 304**.
- Refrigeración del bobinado mediante **baño de agua**.



MATERIALES

- Carcasa exterior y base: **Acero INOX 304**
- Eje: **Acero inoxidable 420**
- Sello mecánico: **Carb/Cer**

ÁREA DE TRABAJO

- Temperatura máx. del agua: **35°C**
- Velocidad mín. de refrigeración: **0,20 m/s**
- Profundidad máx. de inmersión: **200 m**
- Arranques máx. por hora: **30**
- Grado de protección: **IP68**
- Aislamiento clase: **F**



COJINETE AXIAL

BAÑO DE AGUA

MODELO	P ₁		ARRANQUE	I (A)	TENSIÓN	η	COS φ	F. AXIAL	Nm	L	PESO	P.V.P
	kW	Hp	Tipo		3~400V			V				%
MSI65,50	4,0	5,5	Directo / Y-Δ	10,4	3~400/690	0,76	0,77	15.500	2.900	662	43,0	926,00
MSI67,50	5,5	7,5	Directo / Y-Δ	13,7	3~400/690	0,76	0,83	15.500	2.900	727	46,0	1.099,00
MSI610,0	7,5	10	Directo / Y-Δ	18,3	3~400/690	0,78	0,83	15.500	2.900	757	50,0	1.176,00
MSI612,5	9,3	12,5	Directo / Y-Δ	22,0	3~400/690	0,79	0,83	15.500	2.900	787	53,0	1.230,00
MSI615,0	11	15	Directo / Y-Δ	25,8	3~400/690	0,78	0,84	15.500	2.900	827	61,0	1.449,00
MSI617,5	13	17,5	Directo / Y-Δ	30,1	3~400/690	0,80	0,83	15.500	2.900	877	64,0	1.506,00
MSI620,0	15	20	Directo / Y-Δ	33,9	3~400/690	0,81	0,85	15.500	2.900	917	70,0	1.556,00
MSI625,0	18,5	25	Directo / Y-Δ	42,3	3~400/690	0,81	0,84	15.500	2.900	972	76,0	1.745,00
MSI630,0	22	30	Directo / Y-Δ	49,1	3~400/690	0,84	0,83	15.500	2.900	1.047	90,0	1.833,00
MSI635,0	26	35	Directo / Y-Δ	57,5	3~400/690	0,83	0,85	15.500	2.900	1.107	94,0	1.952,00
MSI640,0	30	40	Directo / Y-Δ	66,4	3~400/690	0,83	0,84	27.500	2.900	1.227	102,0	2.317,00
MSI650,0	37	50	Directo / Y-Δ	82,0	3~400/690	0,83	0,83	27.500	2.900	1.347	127,5	2.663,00

Y-Δ: Arranque en Estrella-Triángulo

MOTORES DE 6" SERIE 6SD

DESCRIPCIÓN

- Motores sumergibles de 6" para hidráulicas con acoplamiento **NEMA**.
- Refrigeración del bobinado mediante **baño de aceite**.



MATERIALES

- Envoltente exterior y base: **Acero INOX 304**
- Eje: **Acero INOX 304**
- Cierre mecánico: **Sic/Sic**
- Juntas: **NBR**

ÁREA DE TRABAJO

- Temperatura máx. del agua: **35°C**
- Velocidad mín. de refrigeración: **0,16 m/s**
- Profundidad máx. de inmersión: **200 m**
- Grado de protección: **IP68**
- Aislamiento clase: **B**

BAÑO DE ACEITE

MODELO	P ₁		ARRANQUE	I (A)	TENSIÓN	F. AXIAL	Nm	L	PESO	P.V.P B
	kW	Hp	Tipo	3~400V	V	N	R.P.M.	mm	Kg	TRIF.
6SD4	4,0	5,5	Directo	10,5	3~400	10.000	2.900	645	32,0	720,00
6SD5.5	5,5	7,5	Directo	12,3	3~400	10.000	2.900	675	37,0	796,00
6SD7.5	7,5	10	Directo	16,5	3~400	10.000	2.900	710	40,0	884,00
6SD9.2	9,2	12,5	Directo	20,2	3~400	10.000	2.900	755	44,0	971,00
6SD11	11	15	Directo	23,6	3~400	20.000	2.900	805	47,0	1.089,00
6SD13	13	17,5	Directo	27,6	3~400	20.000	2.900	835	51,0	1.147,00
6SD15	15	20	Directo	31,8	3~400	20.000	2.900	880	55,0	1.262,00
6SD18.5	18,5	25	Directo	38,2	3~400	20.000	2.900	930	60,0	1.942,00

MOTORES DE 6" SERIE MSX6 316

DESCRIPCIÓN

- Motores sumergibles de 6" para hidráulicas con acoplamiento **NEMA**.
- Fabricados en acero **INOX 316**.
- Refrigeración del bobinado mediante **baño de agua**.



MATERIALES

- Envoltente exterior: **Acero INOX 316**
- Eje: **Acero INOX 420**
- Cierre mecánico: **Sic/Sic**
- Juntas: **NBR**

ÁREA DE TRABAJO

- Temperatura máx. del agua: **50°C**
- Velocidad mín. de refrigeración: **0,20 m/s**
- Arranques máx. por hora: **20**
- Grado de protección: **IP68**
- Protección bobinado: **PE2+PA**

BAÑO DE AGUA

8" **DISPONIBLE EN 8"**
BAJO DEMANDA



MODELO	P ₁		ARRANQUE	I (A)	TENSIÓN	F. AXIAL	Nm	L	PESO	P.V.P A
	kW	Hp	Tipo	3~400V	V	N	R.P.M.	mm	Kg	TRIF.
MSX6/5,5	4,0	5,5	Directo / Y-Δ	10,1	3~400/690	20.000	2.900	722	46,0	2.117,00
MSX6/7,5	5,5	7,5	Directo / Y-Δ	13,9	3~400/690	20.000	2.900	751	49,0	2.148,00
MSX6/10	7,5	10	Directo / Y-Δ	18,8	3~400/690	20.000	2.900	831	55,0	2.244,00
MSX6/12,5	9,3	12,5	Directo / Y-Δ	23,2	3~400/690	20.000	2.900	873	60,0	2.433,00
MSX6/15	11	15	Directo / Y-Δ	27,3	3~400/690	20.000	2.900	924	52,0	2.471,00
MSX6/17,5	13	17,5	Directo / Y-Δ	32,1	3~400/690	20.000	2.900	984	69,0	2.667,00
MSX6/20	15	20	Directo / Y-Δ	36,7	3~400/690	20.000	2.900	1.046	75,0	2.759,00
MSX6/25	18,5	25	Directo / Y-Δ	40,5	3~400/690	20.000	2.900	1.079	81,0	2.963,00
MSX6/30	22	30	Directo / Y-Δ	47,5	3~400/690	20.000	2.900	1.179	88,0	3.120,00
MSX6/35	26	35	Directo / Y-Δ	55,9	3~400/690	26.500	2.900	1.290	92,0	3.589,00
MSX6/40	30	40	Directo / Y-Δ	61,7	3~400/690	26.500	2.900	1.320	106,0	3.743,00
MSX6/50	37	50	Directo / Y-Δ	75,3	3~400/690	26.500	2.900	1.420	113,0	3.997,00

Y-Δ: Arranque en Estrella-Triángulo

MOTORES DE 6" SERIE MSM6



DESCRIPCIÓN

- Motores sumergibles de 6" para hidráulicas con acoplamiento **NEMA**.
- Refrigeración del bobinado mediante **baño de agua**.



MATERIALES

- Envoltente exterior: **Acero INOX 304**
- Eje: **Acero INOX 420**
- Cierre mecánico: **Sic/Sic**
- Juntas: **NBR**

ÁREA DE TRABAJO

- Temperatura máx. del agua: **50°C**
- Velocidad mín. de refrigeración: **0,20 m/s**
- Arranques máx. por hora: **20**
- Grado de protección: **IP68**
- Protección bobinado: **PE2+PA**
- Permite conexión de sondas **PT-100**



BAÑO DE AGUA

MODELO	P ₁		ARRANQUE	I	TENSIÓN	F. AXIAL	Nm	L	PESO	P.V.P	C
	kW	Hp									
MSM6075	5,5	7,5	Directo	22,6	3~230	20.000	2.900	751	49,0	1.284,00	
MSM6100	7,5	10	Directo	30,6	3~230	20.000	2.900	831	55,0	1.387,00	
MSM6150	11	15	Y-Δ	44,5	3~230/400	20.000	2.900	924	52,0	1.633,00	
MSM6200	15	20	Y-Δ	60,0	3~230/400	20.000	2.900	1.046	75,0	1.945,00	
MSM6250	19	25	Y-Δ	66,0	3~230/400	20.000	2.900	1.079	81,0	2.164,00	

Y-Δ: Arranque en Estrella-Triángulo

MOTORES DE 6" SERIE MSM6

DESCRIPCIÓN

- Motores sumergibles de 6" para hidráulicas con acoplamiento **NEMA**.
- Refrigeración del bobinado mediante **baño de agua**.



MATERIALES

- Envoltente exterior: **Acero INOX 304**
- Eje: **Acero INOX 420**
- Cierre mecánico: **Sic/Sic**
- Juntas: **NBR**

ÁREA DE TRABAJO

- Temperatura máx. del agua: **50°C**
- Velocidad mín. de refrigeración: **0,20 m/s**
- Arranques máx. por hora: **20**
- Grado de protección: **IP68**
- Protección bobinado: **PE2+PA**
- Permite conexión de sondas **PT-100**



BAÑO DE AGUA

MODELO	P ₁		ARRANQUE	I (A)	TENSIÓN	F. AXIAL	Nm	L	PESO	P.V.P	A
	kW	Hp									
MSM6/5,5	4,0	5,5	Directo	10,1	3~400	20.000	2.900	722	46,0	1.156,70	
MSM6/7,5	5,5	7,5	Directo	13,9	3~400	20.000	2.900	751	49,0	1.187,50	
MSM6/10	7,5	10	Directo	18,8	3~400	20.000	2.900	831	55,0	1.283,50	
MSM6/12,5	9,3	12,5	Directo	23,2	3~400	20.000	2.900	873	60,0	1.471,90	
MSM6/15	11	15	Directo	27,3	3~400	20.000	2.900	924	52,0	1.510,30	
MSM6/17,5	13	17,5	Directo	32,1	3~400	20.000	2.900	984	69,0	1.706,30	
MSM6/20	15	20	Directo	36,7	3~400	20.000	2.900	1.046	75,0	1.798,50	
MSM6/25	18,5	25	Directo	40,5	3~400	20.000	2.900	1.079	81,0	2.002,20	
MSM6/30	22	30	Directo	47,5	3~400	20.000	2.900	1.179	88,0	2.159,70	
MSM6/35	26	35	Directo	55,9	3~400	26.500	2.900	1.290	92,0	2.628,60	
MSM6/40	30	40	Directo	61,7	3~400	26.500	2.900	1.320	106,0	2.782,30	
MSM6/50	37	50	Directo	75,3	3~400	26.500	2.900	1.420	113,0	3.035,90	
MSM6/60	45	60	Directo	96,0	3~400	26.500	2.900	1.480	119,0	3.754,60	

MOTORES DE 8" REBOBINABLES SERIE MS8

DESCRIPCIÓN

- Motores de 8" para hidráulicas con acoplamiento **NEMA**.
- Estátor rebobinable **refrigerado por agua**.



MATERIALES

- Carcasa y tornillería: **Acero INOX 304**
- Base: **Acero INOX 304**
- Cierre mecánico: **Silicio**
- Juntas: **Carbono**

ÁREA DE TRABAJO

- Temperatura máx. agua : **50°C**
- Profundidad máx. de inmersión: **350 m**
- Eficiencia: **IE2**
- Aislamiento clase: **F**
- Protección bobinado: **PE2+PA**
- Grado de protección: **IP68**
- Trabajo horizontal: **Admitido**

BAÑO DE AGUA

MODELO	P ₁		ARRANQUE	I (A)	TENSIÓN		η	COS φ		F. AXIAL	Nm	L	PESO	P.V.P
	kW	Hp			Tipo	3~400V		V	%					
MS8040	30	40	Directo / Y-Δ	63,2	3~400/690	83	0,87	45.000	2.850	996	120,0	3.366,00		
MS8050	37	50	Directo / Y-Δ	76,1	3~400/690	85	0,87	45.000	2.860	1.056	129,0	3.482,00		
MS8060	45	60	Directo / Y-Δ	92,6	3~400/690	85	0,87	45.000	2.860	1.116	138,0	3.805,00		
MS8075	55	75	Directo / Y-Δ	113,2	3~400/690	84	0,88	45.000	2.850	1.286	170,0	4.262,00		
MS8080	59	80	Directo / Y-Δ	122	3~400/690	86	0,87	45.000	2.850	1.286	170,0	4.650,00		
MS8090	66	90	Directo / Y-Δ	137,8	3~400/690	85	0,87	45.000	2.850	1.341	185,0	4.988,00		
MS8100	75	100	Directo / Y-Δ	154,3	3~400/690	84	0,88	45.000	2.850	1.366	186,0	5.057,00		
MS8125	92	125	Directo / Y-Δ	189,2	3~400/690	85	0,87	55.000	2.820	1.471	210,0	5.749,00		

Y-Δ: Arranque en Estrella-Triángulo

MOTORES DE 10" REBOBINABLES SERIE MS10

DESCRIPCIÓN

- Motores sumergibles de 10" para hidráulicas de doble brida.
- **Acoplamiento estriado, opcional con chaveta**.
- Estátor rebobinable **refrigerado por agua**.



MATERIALES

- Carcasa: **Acero INOX 304**
- Eje: **Acero magnético**
- Tornillería: **INOX 304**
- Base: **Fundición**
- Cierre mecánico: **Silicio**

ÁREA DE TRABAJO

- Temperatura máx. del agua: **50°C**
- Profundidad máx. de inmersión: **350 m**
- Arranques máx. por hora: **10**
- Velocidad mín. de refrigeración: **0,50 m/s**
- Protección bobinado: **PE2+PA**
- Grado de protección: **IP68**
- Trabajo horizontal: **Admitido**

BAÑO DE AGUA

MODELO	P ₁		ARRANQUE	I (A)	TENSIÓN		η	COS φ		F. AXIAL	Nm	L	PESO	P.V.P
	kW	Hp			Tipo	3~4000V		V	%					
MS10125	93	125	Directo / Y-Δ	184,9	3~400/690	86	88	75.000	2.905	1.370	256,0	8.017,00		
MS10150	110	150	Directo / Y-Δ	223,6	3~400/690	86	87	75.000	2.905	1.430	284,0	8.972,00		
MS10175	130	175	Directo / Y-Δ	256,3	3~400/690	87	88	75.000	2.920	1.510	311,0	10.233,00		
MS10200	150	200	Directo / Y-Δ	292,1	3~400/690	87	88	75.000	2.910	1.610	338,0	11.406,00		
MS10225	166	225	Directo / Y-Δ	320,6	3~400/690	87	86	75.000	2.905	1.740	370,0	12.232,00		
MS10250	185	250	Directo / Y-Δ	371,8	3~400/690	86	88	75.000	2.905	1.820	400,0	13.063,00		

IMPORTANTE: A la hora de realizar su pedido confirme el tipo de acoplamiento que desea.
Y-Δ: Arranque en Estrella-Triángulo



BOMBEO SOLAR

PYD
ELECTROBOMBAS



BOMBEO SOLAR

En PYD Electrobombas estamos comprometidos en crear los grupos de bombeo solar más eficientes del mercado.

Gracias a nuestra amplia experiencia y conocimientos sobre el mundo del bombeo, hemos creado y configurado una selección de **soluciones de bombeo** para cubrir cualquier necesidad.

Nuestros grupos de bombeo solar son fáciles de instalar y mantener, lo que significa que puede disfrutar de abundante agua sin tener que preocuparse por costosos gastos de energía o mantenimiento.





DESCRIPCIÓN

- El Sistema de bombeo solar es un producto ecológico con **motor brushless DC** de 3 fases de avance y tecnología **MPPT y DSP** para el controlador.
- Este producto supone un **ahorro de costes**, sin necesidad de electricidad ni gasolina.



CARACTERÍSTICAS:

- ✓ Portátil y plegable.
- ✓ Rápido y fácil de instalar.
- ✓ Larga vida útil.
- ✓ Posibilidad de conexión de baterías recargables.
- ✓ Productos de patentes.

		CAUDAL			
m ³ /h	0,2	0,4	0,6	0,7	
l/min	3,3	6,6	10	11,6	

MODELO	DN	TENSIÓN	P MOTOR		Ø	P.V.P.
	Ø"	VDC	W	Hp	mm	
3TSS0.76-55-24/120 System	3/4	24	120	0,15	75	850,00
ALTURA DE CARGA EN METROS						
			54	39	21	12

INCLUIDO

1. Placas solares plegables/portátiles
2. Bomba solar con 20 m. de cable
3. Controlador con conector MC4
4. Accesorios y herramientas
5. 20 m. de cuerda
6. 30 m. de tubo 1/2"
7. Sensores de nivel de agua
8. 20 m. de cable con conector MC4



¡HERRAMIENTAS INCLUIDAS!



BOMBEO SOLAR 2" 3" 4" SERIE GSTH

DESCRIPCIÓN

- Grupo de bombeo solar compuesto por electrobomba de **tornillo helicoidal, motor síncrono de imanes (PSMS)** y controlador. Disponible en 2", 3" y 4".
- Incluye tornillo helicoidal de repuesto.
- Funcionamiento **DC**. Paneles no incluidos.

MATERIALES

- Carcasa: **INOX 304**
- Eje: **Acero magnético**
- Tornillería: **INOX 304**
- Base: **Fundición**
- Cierre mecánico: **Silicio**

ÁREA DE TRABAJO

- Agua química y mecánicamente: **No agresiva**
- Contenido en sólido: **< 50 g/m³**
- Grado de protección: **IP68**
- Aislamiento: **Clase F**
- Temperatura máx.: **Supeditada a t° máx. del motor**



CONTROLADOR



2"

MODELO	DN		PANELES	TENSIÓN	P MOTOR			Ø	CAUDAL									P.V.P. SIN PANELES
	Ø"	Nº			V	kW	Hp		mm	m ³ /h	l/min	0	0,2	0,4	0,6	0,8	1	
GSTH2-1.5/77	3/4	1 x 550W	18 - 60	0,21	0,28	50	77	71	60	49	35	25	10	5	475,40			
GSTH2-1.7/100	3/4	2 x 550W	30 - 110	0,5	0,67	50	100	90	80	71	54	35	19	10	4	545,90		

3"

MODELO	DN		PANELES	TENSIÓN	P MOTOR			Ø	CAUDAL									P.V.P. SIN PANELES
	Ø"	Nº			V	kW	Hp		mm	m ³ /h	l/min	0	0,2	0,5	1	1,2	1,5	
GSTH3-1.2/56	3/4	1 x 550W	18 - 60	0,12	0,16	80	56	40	37	18	557,60							
GSTH3-1.2/77	3/4	1 x 550W	18 - 60	0,21	0,28	80	77	60	55	19	557,60							
GSTH3-1.7/109	3/4	2 x 550W	30 - 110	0,5	0,67	80	109	98	90	67	59	30	592,80					
GSTH3-2.0/150	3/4	3 x 550W	50 - 170	0,75	1	80	150	139	125	88	62	33	2	645,60				

4"

MODELO	DN		PANELES	TENSIÓN	P MOTOR			Ø	CAUDAL									P.V.P. SIN PANELES
	Ø"	Nº			V	kW	Hp		mm	m ³ /h	l/min	0	0,4	0,8	1,2	1,6	2	
GS-4TH-06/48-500	1	2 x 550W	30 - 100	0,5	0,67	100	70	62	55	48	40	28	12	4	825,00			
GS-4TH-07/110-1000	2	4 x 550W	60 - 200	1	1,3	100	125	108	95	85	75	58	24	8	950,00			

PLUG & PLAY

LISTO PARA CONECTAR LOS PANELES Y FUNCIONAR SIN TENER QUE CONFIGURAR NINGÚN PARÁMETRO



BOMBEO SOLAR 3" Y 4" SERIE GSSP



DESCRIPCIÓN

- Grupo de bombeo solar compuesto por electrobomba centrífuga de etapas Serie SP en 3" y 4" de acero **INOX 304**, **motor síncrono de imanes (PSMS)** y controlador.
- Funcionamiento **AC/DC**. Paneles no incluidos.

MATERIALES

- Cuerpo de aspiración: **Acero INOX 304**
- Cuerpo de impulsión: **Acero INOX 304**
- Válvula de retención: **Acero INOX 304**
- Eje: **Acero INOX 304**
- Impulsores/difusores: **Acero INOX 304**



ÁREA DE TRABAJO

- Agua química y mecánicamente: **No agresiva**
- Contenido en sólido: **< 50 g/m³**
- Grado de protección: **IP68**
- Aislamiento: **Clase F**
- Temperatura máx.: **Supeditada a t° máx. del motor**



CONTROLADOR

3"

MODELO	DN	PANELES	TENSIÓN	P MOTOR		Ø"	CAUDAL							P.V.P. SIN PANELES
	Ø"	Nº	V	kW	Hp		m ³ /h	0	0,5	1	2	3	4	
GSSP3-4.5/80	1 1/4	3 x 550W	50 - 170	0,6	0,8	80	0	0,5	1	2	3	4	5	927,00
GSSP3-5.0/110	1 1/4	4 x 550W	60 - 200	1,1	1,5	80	0	8,3	16,7	33,3	50	66,7	83,3	952,90

4"

MODELO	DN	PANELES	TENSIÓN	P MOTOR		Ø"	CAUDAL							P.V.P. SIN PANELES	
	Ø"	Nº	V	kW	Hp		m ³ /h	0	0,5	1	1,5	2	2,5		3
GSSP4-4.0/115	1 1/4	3 x 550W	50 - 170	0,75	1,1	100	0	8,3	16,7	25	33,3	41,7	50	58,3	901,10
GSSP4-4.0/145	1 1/4	4 x 550W	60 - 200	1,1	1,5	100	0	8,3	16,7	25	33,3	41,7	50	58,3	937,40

4"

MODELO	DN	PANELES	TENSIÓN	P MOTOR		Ø"	CAUDAL							P.V.P. SIN PANELES
	Ø"	Nº	V	kW	Hp		m ³ /h	0	1	2	3	4	5	
GSSP4-6.5/67	1 1/4	3 x 550W	50 - 170	0,75	1,1	100	0	16,7	33,3	50	66,7	83,3	100	854,50
GSSP4-6.5/101	1 1/4	4 x 550W	60 - 200	1,1	1,5	100	0	16,7	33,3	50	66,7	83,3	100	895,90

4"

MODELO	DN	PANELES	TENSIÓN	P MOTOR		Ø"	CAUDAL							P.V.P. SIN PANELES	
	Ø"	Nº	V	kW	Hp		m ³ /h	0	2	3	4	5	6		7
GSSP4-9.0/48	2	3 x 550W	50 - 170	0,75	1,1	100	0	33,3	50	66,7	83,3	100	116,7	133,3	895,90
GSSP4-9.0/70	2	4 x 550W	60 - 200	1,1	1,5	100	0	33,3	50	66,7	83,3	100	116,7	133,3	927,00

4"

MODELO	DN	PANELES	TENSIÓN	P MOTOR		Ø"	CAUDAL							P.V.P. SIN PANELES	
	Ø"	Nº	V	kW	Hp		m ³ /h	0	2	4	6	8	10		12
GSSP4-15.0/55	2	4 x 550W	60 - 200	1,1	1,5	100	0	33,3	66,7	100	133,3	166,7	200	233,3	989,20

BOMBEO SOLAR 4" SERIE GSPRO



DESCRIPCIÓN

- Grupo de bombeo solar con electrobomba centrífuga de etapas Serie SP de 4" y **motor síncrono de imanes (PSMS)**. Paneles y cuadro monitor no incluido.
- La electrónica del motor adapta la potencia (0,5 hasta 3 Hp) en función a la energía solar suministrada. Diseñado para operar tanto con energía solar como con suministro eléctrico.
- **A DEMANDA:** Cuadro **monitor GSPRO** que permite el **cambio automático entre alimentación AC y DC. NO INCLUIDO**. Compatible con integración de sondas de nivel y módulo GPRS integrado.

MATERIALES

- Cuerpo de aspiración: **Acero INOX 304**
- Cuerpo de impulsión: **Acero INOX 304**
- Válvula de retención: **Acero INOX 304**
- Eje: **Acero INOX 304**
- Impulsores/difusores: **Acero INOX 304**

ÁREA DE TRABAJO

- Agua química y mecánicamente: **No agresiva**
- Contenido en sólido: **< 50 g/m³**
- Temperatura máx.: **Supeditada a t° máx. del motor**



MONITOR GSSPRO



GSPRO/5-15

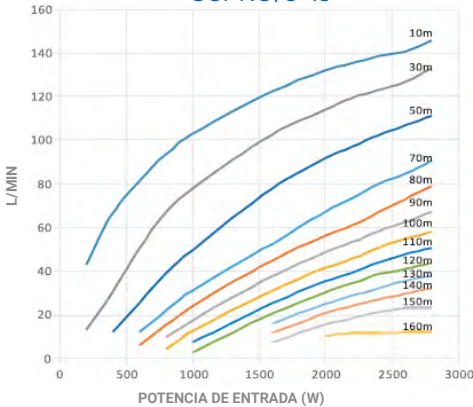

GSPRO/8-8

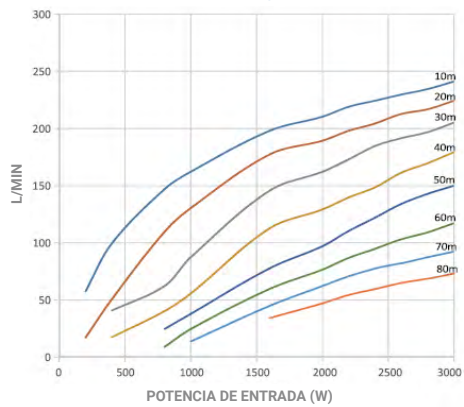

GSPRO/5

MODELO	DN Ø"	CORRIENTE	PANELES Nº	P MOTOR HP	Ø"	CAUDAL								P.V.P. SIN PANELES
						m ³ /h	l/min	ALTURA DE CARGA EN METROS						
GSPRO/5-15	1 ¼	AC/DC	1 x 550W	0,5 - 3	100	1,2	20	50	30	17	8	8,4	1.650,00	
			2 x 550W			2,4	40	60	29	11	140			
			3 x 550W			3,6	60	46	29	11	140			
			4 x 550W			4,8	80	63	47	30	10	140		
			5 x 550W			6	100	78	60	46	27	140		

GSPRO/8

MODELO	DN Ø"	CORRIENTE	PANELES Nº	P MOTOR HP	Ø"	CAUDAL					P.V.P. SIN PANELES		
						m ³ /h	l/min	ALTURA DE CARGA EN METROS					
GSPRO/8-8	2	AC/DC	1 x 550W	0,5 - 3	100	3	50	29	12	14	15	1.650,00	
			2 x 550W			6	100	42	28	14	250		
			3 x 550W			9	150	62	42	27	250		
			4 x 550W			12	200	79	49	34	15		250
			5 x 550W			15	250	80	60	42	24		250
			6 x 550W			18	300	88	68	50	32		10

CUADRO MONITOR AC/DC SERIE GSPRO

DESCRIPCIÓN

- **Cuadro monitor GSPRO** que permite el cambio automático entre alimentación AC y DC para el grupo de bombeo solar **GSPRO**.
- Adecuado para fuentes de alimentación AC 1~230V y DC simultáneas.
- Puede conmutarse de forma manual o automática entre dos fuentes de alimentación según la irradiación solar.
- **Conexión disponible para sensores de nivel** tanto en pozo como en depósito.
- Indica si la instalación está encendida, apagada o si el tanque de agua está lleno o vacío (con sensor de nivel).
- El monitor permite trabajar con bombas hasta 2,2 kW / 3,0 Hp.



MÓDULO GPRS INTEGRADO

FUNCIONES

- ✔ Permite visualizar la potencia de entrada en la pantalla.
- ✔ Control de nivel mediante sondas o interruptor de nivel
- ✔ Control de presión mediante presostato.
- ✔ Interruptor de encendido y apagado de bomba
- ✔ Módulo GPRS/RMS integrado.
- ✔ Protección contra trabajo en seco (con rearme tras 10 min.)
- ✔ Protección contra sobretensión.
- ✔ Fabricación resistente gracias a la protección IP65.
- ✔ Posibilidad de seleccionar la fuente de alimentación de entrada:
 - » **MODO AC** - La fuente de alimentación puede ser la red eléctrica monofásica 230V o un generador.
 - » **MODO DC** - La fuente de alimentación puede provenir de paneles solares o baterías.
 - » **MODO AUTO** - La fuente de alimentación entrante se puede conmutar entre dos fuentes según la irradiación solar.

MODELO	POTENCIA	ALIMENTACIÓN	P.V.P. C
CUADRO MONITOR GSPRO	Hasta 2,2 kW	AC/DC	410,00

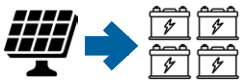
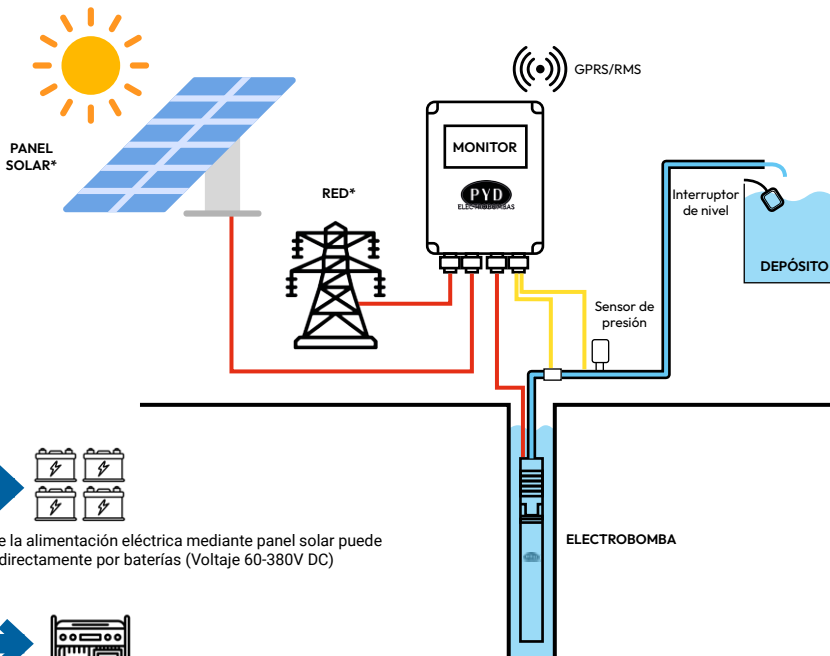

(*) El gráfico de la alimentación eléctrica mediante panel solar puede ser sustituido directamente por baterías (Voltaje 60-380V DC)

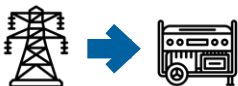

(*) El gráfico del cableado con la red eléctrica puede ser sustituido directamente por la fuente de alimentación del generador.

BOMBEO SOLAR 4" 6" y 8" SERIE GVS

DESCRIPCIÓN

- Grupo solar compuesto por electrobomba centrífuga de etapas Serie SP en **INOX**, **motor síncrono de imanes (PSMS)** y cuadro con variador de frecuencia. Disponible en 4", 6" y 8". Paneles no incluidos.
- ✓ El **cuadro PYDSOLAR** permite al grupo funcionar con corriente continua mediante paneles solares o con corriente alterna de tensión trifásica (**AC/DC**).

MATERIALES

- Cuerpo de aspiración: **Acero INOX 304**
- Cuerpo de impulsión: **Acero INOX 304**
- Válvula de retención: **Acero INOX 304**
- Eje: **Acero INOX 304**
- Impulsores: **Acero INOX 304**
- Difusores: **Acero INOX 304**

ÁREA DE TRABAJO

- Agua química y mecánicamente: **No agresiva**
- Contenido en sólido: **< 50 g/m³**
- Temperatura máx.: **Supeditada a t° máx. del motor**



4"

MODELO	DN	Nº PANELES		T BOMBA		P MOTOR		Ø"
	Ø"	Filas	VDC	V	kW	Hp	mm	
GVS-4SP1/A	1 ¼	1	7 x 550W	230	1,5	2,0	100	
GVS-4SP1/B	1 ¼	1	7 x 550W	230	2,2	3,0	100	

CAUDAL											P.V.P. SIN PANELES
m ³ /h	0	0,4	0,6	0,8	1,1	1,4	1,7	1,9	2,1	2,9	
l/min	0	6,6	10	13,3	18,3	23,3	28,3	31,6	35	48,3	
ALTURA DE CARGA EN METROS											
	232,5	216,5	205,2	191,4	168	144,7	126,4	118,5	114,4	112	1.840,00
	310	294,5	279	259	224,7	191,8	167	156,7	151,7	151,4	2.003,70

4"

MODELO	DN	Nº PANELES		T BOMBA		P MOTOR		Ø"
	Ø"	Filas	VDC	V	kW	Hp	mm	
GVS-4SP2/A	1 ¼	1	7 x 550W	230	1,5	2,0	100	
GVS-4SP2/B	1 ¼	1	7 x 550W	230	2,2	3,0	100	

CAUDAL											P.V.P. SIN PANELES
m ³ /h	0	0,6	1,5	2	2,9	3,4	4	4,5	4,9	5,3	
l/min	0	10	25	33,3	48,3	56,6	66,6	75	81,6	88,3	
ALTURA DE CARGA EN METROS											
	180	170	133,6	118,3	93,6	80,6	63,5	47,8	34,4	19,5	1.845,00
	265,4	249,7	237,5	220,3	160,5	123,7	91,5	81	82	82,6	1.977,70

4"

MODELO	DN	Nº PANELES		T BOMBA		P MOTOR		Ø"
	Ø"	Filas	VDC	V	kW	Hp	mm	
GVS-4SP5/A	1 ¼	1	7 x 550W	230	1,5	2,0	100	
GVS-4SP5/B	1 ¼	1	7 x 550W	230	2,2	3,0	100	
GVS-4SP5/C	1 ¼	1	15 x 550W	400	3,7	5,0	100	

CAUDAL											P.V.P. SIN PANELES
m ³ /h	0	0,5	1	1,5	2	3	4,5	5,5	6,2	7	
l/min	0	8,3	16,6	25	33,3	50	75	91,6	103,3	116,6	
ALTURA DE CARGA EN METROS											
	134,3	132,2	123,5	113,5	104,4	88,7	64,2	49	39	15,2	1.784,00
	183,8	181,3	174,2	167,6	162,8	153	116,7	82	60,2	33	1.878,70
	356	348,4	337,3	327,3	318,6	297,2	227	160,7	118	75,5	2.150,70

4"

MODELO	DN	Nº PANELES		T BOMBA		P MOTOR		Ø"
	Ø"	Filas	VDC	V	kW	Hp	mm	
GVS-4SP6/A	1 ½	1	7 x 550W	230	1,5	2,0	100	
GVS-4SP6/B	1 ½	1	7 x 550W	230	2,2	3,0	100	
GVS-4SP6/C	1 ½	1	15 x 550W	400	3,7	5,0	100	
GVS-4SP6/D	1 ½	2	15 x 550W	400	5,5	7,5	100	

CAUDAL											P.V.P. SIN PANELES
m ³ /h	0	1,7	2,8	4,6	5,5	6	7,5	8	9	9,7	
l/min	0	28,3	46,6	76,6	91,6	100	125	133,3	150	161,6	
ALTURA DE CARGA EN METROS											
	99,9	88,4	76,2	59,6	54	51	38,6	31,7	14,5		1.751,00
	124	106,2	93,3	68,4	58,4	53,7	38,9	32,9	17,5		1.841,70
	261,3	239,4	228,3	208	194,5	185,6	150	134,6	96	60,6	2.080,70
	309,7	284,4	268,3	244,7	229,4	218,6	173,8	154,5	109	75,5	2.364,80

Si no encuentra la curva de trabajo que necesita, contáctenos. Podemos ofrecerle una configuración y curva a medida para su instalación.

4"

MODELO	DN Ø"	N° PANELES		T BOMBA V	P MOTOR		Ø"	CAUDAL										P.V.P. SIN PANELES															
		Filas	VDC		kW	Hp		m³/h	l/min	ALTURA DE CARGA EN METROS																							
GVS-4SP12/A	2	1	7 x 550W	230	1,5	2,0	100	0	2	3	5,5	9	9,5	12	14,5	15	0	33	50	91,6	150	158,3	200	241,6	250	55,7	52	49	41,3	30,2	28,7	20,7	1.791,00
GVS-4SP12/B	2	1	7 x 550W	230	2,2	3,0	100	0	33	50	91,6	150	158,3	200	241,6	250	78	68,6	63,2	52,8	34,6	31,7	20,8									1.898,70	
GVS-4SP12/C	2	1	15 x 550W	400	3,7	5,0	100	0	33	50	91,6	150	158,3	200	241,6	250	139,4	127,8	122,3	112,6	88	81,8	44	13,8								2.113,70	
GVS-4SP12/D	2	2	15 x 550W	400	5,5	7,5	100	0	33	50	91,6	150	158,3	200	241,6	250	174,3	163,6	158,5	147	132,8	130,5	113	90,2	76							2.406,80	
GVS-4SP12/E	2	2	15 x 550W	400	7,5	10	100	0	33	50	91,6	150	158,3	200	241,6	250	290,3	274,8	266,8	244,8	220	216,5	190,2	151	127							2.809,80	

4"

MODELO	DN Ø"	N° PANELES		T BOMBA V	P MOTOR		Ø"	CAUDAL										P.V.P. SIN PANELES															
		Filas	VDC		kW	Hp		m³/h	l/min	ALTURA DE CARGA EN METROS																							
GVS-4SP25/A	2	1	7 x 550W	230	2,2	3,0	100	0	8	9	11	12,5	14	17,5	20	24	39	35,5	35,2	34,5	33,5	32,3	29,5	27,5	19							1.942,70	
GVS-4SP25/B	2	1	15 x 550W	400	3,7	5,0	100	0	133,3	150	183,3	208,3	233,3	291,6	333,3	400	98,9	88,8	86	80,5	77,4	75,2	69,2	59,3	34,8								2.164,70
GVS-4SP25/C	2	2	15 x 550W	400	5,5	7,5	100	0	133,3	150	183,3	208,3	233,3	291,6	333,3	400	103,4	92,4	90,5	87	85	82,8	76,2	68	51								2.403,80
GVS-4SP25/D	2	2	15 x 550W	400	7,5	10	100	0	133,3	150	183,3	208,3	233,3	291,6	333,3	400	133,6	117,8	115	110	106,8	104	95,8	85	58								2.711,80

6"

MODELO	DN Ø"	N° PANELES		T BOMBA V	P MOTOR		Ø"	CAUDAL										P.V.P. SIN PANELES														
		Filas	VDC		kW	Hp		m³/h	l/min	ALTURA DE CARGA EN METROS																						
GVS-6SP30/A	2 ½	3	15 x 550W	400	9,2	12,5	133	0	9	12,5	15,5	17	19	21	28	153,6	143,4	136,3	127,3	122	114	106	74,2									3.221,80
GVS-6SP30/B	2 ½	3	15 x 550W	400	11	15	133	0	150	208,3	258,3	283,3	316,6	350	466,6	188,4	182	176,5	167,2	161	151,3	141	93,5									3.506,80
GVS-6SP30/C	2 ½	4	15 x 550W	400	15	20	133	0	150	208,3	258,3	283,3	316,6	350	466,6	258	251,8	243	229,5	220,8	207,5	192,5	131,2									4.430,50

6"

MODELO	DN Ø"	N° PANELES		T BOMBA V	P MOTOR		Ø"	CAUDAL										P.V.P. SIN PANELES														
		Filas	VDC		kW	Hp		m³/h	l/min	ALTURA DE CARGA EN METROS																						
GVS-6SP50/A	3	3	15 x 550W	400	9,2	12,5	133	0	10	18,5	23	28	31	40,5	50	86,3	85	81,3	77,4	72,2	68,7	56,3	39,2									3.171,80
GVS-6SP50/B	3	3	15 x 550W	400	11	15	133	0	166,6	308,3	383,3	466,6	516,6	675	833,3	125,3	120,6	115,3	110	102,6	97,9	83,5	60,2									3.506,80
GVS-6SP50/C	3	4	15 x 550W	400	15	20	133	0	166,6	308,3	383,3	466,6	516,6	675	833,3	177,5	175,6	166	158,2	148,4	142,2	120,3	84,3									4.537,50

Si no encuentra la curva de trabajo que necesita, contáctenos. Podemos ofrecerle una configuración y curva a medida para su instalación.

6"

MODELO	DN	N° PANELES		T BOMBA		P MOTOR		Ø"
	Ø"	Filas	VDC	V	kW	Hp	mm	
GVS-6SP75/A	4	3	15 x 550W	400	9,2	12,5	133	
GVS-6SP75/B	4	3	15 x 550W	400	11	15	133	

CAUDAL									P.V.P. C SIN PANELES
m³/h	0	10	20	30	40	50	60	70	
l/min	0	166,6	333,3	500	666,6	833,3	1000	1166,6	
ALTURA DE CARGA EN METROS									
	65,3	64,7	61,5	56,3	50	43,6	37,6	29,7	3.118,80
	87,1	87	82,9	72,3	61	52,3	44,8	35,1	3.396,80

6"

MODELO	DN	N° PANELES		T BOMBA		P MOTOR		Ø"
	Ø"	Filas	VDC	V	kW	Hp	mm	
GVS-6SP100/A	4	3	15 x 550W	400	9,2	12,5	146	
GVS-6SP100/B	4	4	15 x 550W	400	15	20	146	

CAUDAL									P.V.P. C SIN PANELES
m³/h	0	15	25	40	55	60	80	95	
l/min	0	250	416,6	666,6	916,6	1000	1333,3	1583,3	
ALTURA DE CARGA EN METROS									
	68,6	66,7	64,3	56	46	43	32,2	28,5	3.122,80
	110,2	109	106	93,6	77,8	73	55,8	37,5	4.224,50

8"

MODELO	DN	N° PANELES		T BOMBA		P MOTOR		Ø"
	Ø"	Filas	VDC	V	kW	Hp	mm	
GVS-8SP125/A	5	4	15 x 550W	400	15	20	172	

CAUDAL								P.V.P. C SIN PANELES
m³/h	0	19	35	63	100	125		
l/min	0	316,6	583,3	1050	1666,6	2083,3		
ALTURA DE CARGA EN METROS								
	64,2	61	57,4	47,8	36	24,1	4.710,50	

Si no encuentra la curva de trabajo que necesita, contáctenos. Podemos ofrecerle una configuración y curva a medida para su instalación.



CUADROS SOLARES SERIE PYDSOLAR

DESCRIPCIÓN

- ✓ Los cuadros **PYDSOLAR** con variador de frecuencia han sido diseñados para la gestión eficiente de electrobombas trifásicas, proporcionando una solución versátil en términos de alimentación eléctrica y optimización del rendimiento hidráulico.
- ✓ Su tecnología permite el funcionamiento tanto con **corriente continua (DC)** proveniente de paneles solares, como con **corriente alterna (AC)** en sistemas de alimentación trifásica.

Gracias a su software preinstalado, **optimizan el consumo energético** al ajustar de forma precisa la potencia y la frecuencia que entrega el motor en cada momento.

En sistemas alimentados por paneles solares, **la frecuencia de la bomba se regula automáticamente** según la intensidad solar disponible, sin restricciones de potencia.

En PYD hemos diseñado 3 configuraciones de modelos que permiten incluir funciones para adaptarse a las necesidades específicas de cada instalación: **ESTÁNDAR, ESTÁNDAR+ y PRO.**



CARACTERÍSTICAS	ESTÁNDAR	ESTÁNDAR+	PRO
APTO PARA MOTOR DE IMANES PERMANENTES	✓	✓	✓
APTO PARA MOTOR ASÍNCRONO	✓	✓	✓
CONEXIÓN DE SENSORES	✓	✓	✓
PROTECCIÓN DE TENSIÓN	✓	✓	✓
PROTECCIÓN DE INTENSIDAD	✓	✓	✓
DETECCIÓN POR FALTA DE AGUA	✓	✓	✓
DETECCIÓN DE BAJA FRECUENCIA	✓	✓	✓
REARME AUTOMÁTICO	✓	✓	✓
OPTIMIZACIÓN MPPT	✓	✓	✓
MÓDULO GPRS 4G	✗	✓	✓
TRANSDUCTOR DE PRESIÓN	✗	✓	✓
MODO HÍBRIDO	✗	✓	✓
PANTALLA LCD TÁCTIL	✗	✗	✓
PROGRAMADOR DE RIEGO HASTA 15 SECTORES	✗	✗	✓

DESCRIPCIÓN

- El cuadro **PYDSOLAR ESTÁNDAR** con variador de frecuencia está diseñado para alimentar electrobombas trifásicas.
- Permite el funcionamiento con corriente continua mediante paneles solares o con corriente alterna de tensión trifásica (**AC/DC**).
- Su software preinstalado **optimiza el consumo energético** ajustando de forma precisa la potencia y la frecuencia que entrega el motor en cada momento. En sistemas alimentados por paneles solares, **la frecuencia de la bomba se regula automáticamente** según la intensidad solar disponible, sin restricciones de potencia.



CARACTERÍSTICAS

- ✓ **PROTECCIÓN TÉRMICA:** Electrónica del motor mediante valor parametrizable. Sobreconsumo (fallo motor) y subconsumo (falta de agua).
- ✓ **DETECCIÓN DE FALTA DE AGUA.**
- ✓ **REARME AUTOMÁTICO:**
 - Fallo de tensión.
 - Detección de luz débil.
 - Falta de agua (Subconsumo)
 - Sobreintensidad (Fallo motor)
- ✓ **SEGUIMIENTO AUTOMÁTICO DEL ALGORITMO MPPT.** No es necesario un sensor de radiación solar.

MODELO	POTENCIA MÁXIMA 50/60HZ		TENSIÓN		ALIMENTACIÓN		P.V.P.
			V	A (220V)	A (380V)	TENSIÓN	
						VDC	
PYDSOLAR 2.2/1~230	2,2	3,0	1~230	16,0	-	260 - 360	1.423,80
PYDSOLAR 1.5/3~230	1,5	2,0	3~230	7,0	-	260 - 360	1.142,00
PYDSOLAR 2.2/3~230	2,2	3,0	3~230	9,6	-	260 - 360	1.184,70
PYDSOLAR 4.0/3~230	4,0	5,5	3~230	17,0	-	260 - 360	1.423,80
PYDSOLAR 5.5/3~230	5,5	7,5	3~230	25,0	-	260 - 360	1.609,80
PYDSOLAR 3.7/3~400	3,7	5,0	3~400	-	9,0	600 - 760	1.184,70
PYDSOLAR 5.5/3~400	5,5	7,5	3~400	-	13,0	600 - 760	1.312,80
PYDSOLAR 7.5/3~400	7,5	10	3~400	-	17,0	600 - 760	1.423,80
PYDSOLAR 11.0/3~400	11	15	3~400	-	25,0	600 - 760	1.609,80
PYDSOLAR 15.0/3~400	15	20	3~400	-	32,0	600 - 760	2.172,50
PYDSOLAR 18.5/3~400	18,5	25	3~400	-	37,0	600 - 760	2.428,00
PYDSOLAR 22.0/3~400	22	30	3~400	-	45,0	600 - 760	2.603,10
PYDSOLAR 30.0/3~400	30	40	3~400	-	60,0	600 - 760	3.436,80
PYDSOLAR 37.0/3~400	37	50	3~400	-	75,0	600 - 760	3.811,80
PYDSOLAR 45.0/3~400	45	60	3~400	-	91,0	600 - 760	4.473,70
PYDSOLAR 55.0/3~400	55	75	3~400	-	112,0	600 - 760	4.956,20

AVISO: Seleccione el variador en función del amperaje nominal del motor, considerando que la potencia es una referencia orientativa

Respete la velocidad mínima de refrigeración de los motores. Si es necesario, instale una camisa de refrigeración.

DESCRIPCIÓN

- El cuadro **PYDSOLAR ESTÁNDAR+** con variador de frecuencia está diseñado para alimentar electrobombas trifásicas, ofreciendo flexibilidad en su alimentación.
- Pueden funcionar con corriente continua mediante paneles solares o con corriente alterna de tensión trifásica (AC/DC).
- Su software preinstalado **optimiza el consumo energético** al ajustar de forma precisa la potencia y la frecuencia que entrega el motor en cada momento. En sistemas alimentados por paneles solares, **la frecuencia de la bomba se regula automáticamente** según la intensidad solar disponible, sin restricciones de potencia.
- **A diferencia de la versión ESTÁNDAR este modelo incluye nuevas prestaciones como el modo híbrido o un módulo GPRS entre otros.**



CARACTERÍSTICAS

- ✓ **TRANSDUCTOR DE PRESIÓN** 10 bar (Disponible hasta 25 bar)
- ✓ **MODO HÍBRIDO**
- ✓ **MÓDULO GPRS 4G** para control remoto del variador a través de app/web.
- ✓ **PROTECCIÓN TÉRMICA:** Electrónica del motor mediante valor parametrizable. Sobreconsumo (fallo motor) y subconsumo (falta de agua).
- ✓ **DETECCIÓN DE FALTA DE AGUA.**
- ✓ **REARME AUTOMÁTICO:**
 - Fallo de tensión.
 - Detección de luz débil.
 - Falta de agua (Subconsumo)
 - Sobreintensidad (Fallo motor)
- ✓ **SEGUIMIENTO AUTOMÁTICO DEL ALGORITMO MPPT.** No es necesario un sensor de radiación solar.

MODELO	POTENCIA MÁXIMA 50/60HZ		TENSIÓN			ALIMENTACIÓN		P.V.P.
	kW	Hp	V	A (220V)	A (380V)	TENSIÓN	VDC	
PYDSOLAR 2.2/1~230	2,2	3,0	1~230	16,0	-	260 - 360	2.166,50	
PYDSOLAR 1.5/3~230	1,5	2,0	3~230	7,0	-	260 - 360	1.806,80	
PYDSOLAR 2.2/3~230	2,2	3,0	3~230	9,6	-	260 - 360	1.849,40	
PYDSOLAR 4.0/3~230	4,0	5,5	3~230	17,0	-	260 - 360	2.166,50	
PYDSOLAR 5.5/3~230	5,5	7,5	3~230	25,0	-	260 - 360	2.352,50	
PYDSOLAR 3.7/3~400	3,7	5,0	3~400	-	9,0	600 - 760	1.849,40	
PYDSOLAR 5.5/3~400	5,5	7,5	3~400	-	13,0	600 - 760	1.977,50	
PYDSOLAR 7.5/3~400	7,5	10	3~400	-	17,0	600 - 760	2.166,50	
PYDSOLAR 11.0/3~400	11	15	3~400	-	25,0	600 - 760	2.352,50	
PYDSOLAR 15.0/3~400	15	20	3~400	-	32,0	600 - 760	2.848,40	
PYDSOLAR 18.5/3~400	18,5	25	3~400	-	37,0	600 - 760	3.138,00	
PYDSOLAR 22.0/3~400	22	30	3~400	-	45,0	600 - 760	3.313,00	
PYDSOLAR 30.0/3~400	30	40	3~400	-	60,0	600 - 760	4.244,20	
PYDSOLAR 37.0/3~400	37	50	3~400	-	75,0	600 - 760	4.656,40	
PYDSOLAR 45.0/3~400	45	60	3~400	-	91,0	600 - 760	5.318,20	
PYDSOLAR 55.0/3~400	55	75	3~400	-	112,0	600 - 760	5.800,70	

⚠️ AVISO: Seleccione el variador en función del amperaje nominal del motor, considerando que la potencia es una referencia orientativa

Respete la velocidad mínima de refrigeración de los motores. Si es necesario, instale una camisa de refrigeración.

DESCRIPCIÓN

- El cuadro **PYDSOLAR PRO** con variador de frecuencia está diseñado para alimentar electrobombas trifásicas, ofreciendo flexibilidad en su alimentación.
- Pueden funcionar con corriente continua mediante paneles solares o con corriente alterna de tensión trifásica (AC/DC).
- Su software preinstalado **optimiza el consumo energético** al ajustar de forma precisa la potencia y la frecuencia que entrega el motor en cada momento. En sistemas alimentados por paneles solares, **la frecuencia de la bomba se regula automáticamente** según la intensidad solar disponible, sin restricciones de potencia.
- **El modelo PRO es la configuración más completa.**

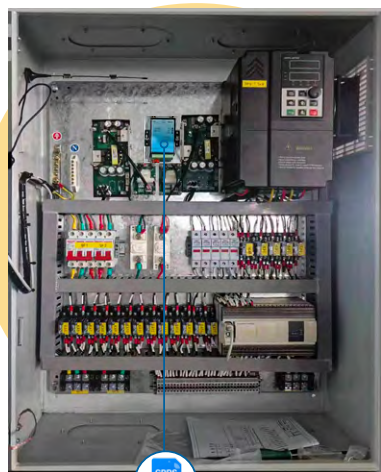

CARACTERÍSTICAS

- ✓ **PROGRAMADOR DE RIEGO** para conexión de hasta 15 electroválvulas.
- ✓ **PANTALLA LCD TÁCTIL** para comando del variador y visualización de parámetros.
- ✓ **TRANSDUCTOR DE PRESIÓN** 10 bar (Disponible hasta 25 bar)
- ✓ **MODO HÍBRIDO**
- ✓ **MÓDULO GPRS 4G** para control remoto del variador a través de app/web.
- ✓ **PROTECCIÓN TÉRMICA:** Electrónica del motor mediante valor parametrizable. Sobreconsumo (fallo motor) y subconsumo (falta de agua).
- ✓ **DETECCIÓN DE FALTA DE AGUA.**
- ✓ **REARME AUTOMÁTICO:**
 - Fallo de tensión.
 - Detección de luz débil.
 - Falta de agua (Subconsumo)
 - Sobreintensidad (Fallo motor)
- ✓ **SEGUIMIENTO AUTOMÁTICO DEL ALGORITMO MPPT.** No es necesario un sensor de radiación solar.

MODELO	POTENCIA MÁXIMA 50/60HZ		TENSIÓN		INT. MÁXIMA		ALIMENTACIÓN		P.V.P.
			V	A (220V)	A (380V)	TENSIÓN			
						VDC			
PYDSOLAR 2.2/1~230	2,2	3,0	1~230	16,0	-	260 - 360		4.355,30	
PYDSOLAR 1.5/3~230	1,5	2,0	3~230	7,0	-	260 - 360		4.355,30	
PYDSOLAR 2.2/3~230	2,2	3,0	3~230	9,6	-	260 - 360		4.355,30	
PYDSOLAR 4.0/3~230	4,0	5,5	3~230	17,0	-	260 - 360		Consultar	
PYDSOLAR 5.5/3~230	5,5	7,5	3~230	25,0	-	260 - 360		Consultar	
PYDSOLAR 3.7/3~400	3,7	5,0	3~400	-	9,0	600 - 760		4.773,80	
PYDSOLAR 5.5/3~400	5,5	7,5	3~400	-	13,0	600 - 760		4.773,80	
PYDSOLAR 7.5/3~400	7,5	10	3~400	-	17,0	600 - 760		4.773,80	
PYDSOLAR 11.0/3~400	11	15	3~400	-	25,0	600 - 760		4.773,80	
PYDSOLAR 15.0/3~400	15	20	3~400	-	32,0	600 - 760		Consultar	
PYDSOLAR 18.5/3~400	18,5	25	3~400	-	37,0	600 - 760		Consultar	
PYDSOLAR 22.0/3~400	22	30	3~400	-	45,0	600 - 760		Consultar	
PYDSOLAR 30.0/3~400	30	40	3~400	-	60,0	600 - 760		Consultar	
PYDSOLAR 37.0/3~400	37	50	3~400	-	75,0	600 - 760		Consultar	
PYDSOLAR 45.0/3~400	45	60	3~400	-	91,0	600 - 760		Consultar	
PYDSOLAR 55.0/3~400	55	75	3~400	-	112,0	600 - 760		Consultar	

⚠ **AVISO:** Seleccione el variador en función del amperaje nominal del motor, considerando que la potencia es una referencia orientativa

Respete la velocidad mínima de refrigeración de los motores. Si es necesario, instale una camisa de refrigeración.

Monitoriza tu bombeo solar en tiempo real

DESCRIPCIÓN

- El **módulo GPRS integrado** permite la **monitorización y control remoto** del sistema de bombeo solar, garantizando una gestión avanzada y optimizada
- **A través de una conexión 4G mediante tarjeta SIM**, se obtiene acceso en tiempo real a parámetros de funcionamiento, registros históricos y alertas del sistema.
- Esta tecnología mejora la eficiencia operativa y el mantenimiento preventivo, permitiendo ajustes y diagnósticos a distancia **sin necesidad de intervención presencial**.



A través de la aplicación móvil o plataforma web se envían parámetros de configuración en tiempo real.

El módulo GPRS recibe la configuración mediante red 4G. Procesa y transmite las órdenes al variador de frecuencia sin necesidad de intervención local.

El variador ajusta el funcionamiento del grupo de bombeo solar según los parámetros.

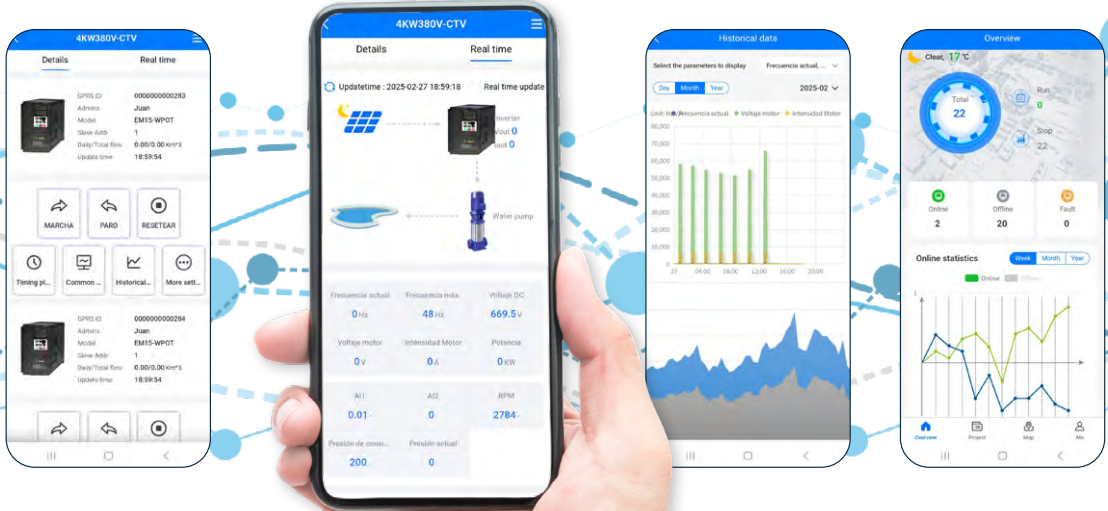

VARIADOR DE FRECUENCIA PYD



DESCRIPCIÓN

- El variador de frecuencia de la serie PYD ha sido desarrollado bajo un concepto innovador, incorporando tecnologías avanzadas de control para optimizar el rendimiento y la eficiencia.
- Equipado con un modelo de **control vectorial avanzado**, este inversor permite un alto par motor incluso a bajas velocidades, garantizando una regulación precisa y estable del movimiento. Su capacidad de control de velocidad variable permite **adaptar el funcionamiento del motor a las necesidades de bombeo**, optimizando el consumo energético y reduciendo el desgaste mecánico.
- Optimizado para el comando de motores de imanes permanentes AC y energía solar



MODELO	CORRIENTE ELÉCTRICA		INTENSIDAD MÁXIMA		P.V.P. ^C
	DC	AC	A (220V)	A (380V)	
V.FREC/1.5	260 - 360	220	5,1	-	458,80
V.FREC/2.2	260 - 360	220	9,0	-	625,60
V.FREC/4.0	260 - 360	220	13,0	-	734,00
V.FREC/5.5	260 - 360	220	25,0	-	909,10
V.FREC/3.7	600 - 760	380	-	9,0	500,40
V.FREC/5.5	600 - 760	380	-	13,0	625,60
V.FREC/7.5	600 - 760	380	-	17,0	734,00
V.FREC/11.0	600 - 760	380	-	25,0	909,10
V.FREC/15.0	600 - 760	380	-	32,0	1.055,10
V.FREC/18.5	600 - 760	380	-	37,0	1.284,50
V.FREC/22.0	600 - 760	380	-	45,0	1.455,40
V.FREC/30.0	600 - 760	380	-	60,0	2.193,60
V.FREC/37.0	600 - 760	380	-	75,0	2.460,50
V.FREC/45.0	600 - 760	380	-	91,0	3.106,90
V.FREC/55.0	600 - 760	380	-	112,0	3.578,10
V.FREC/75.0	600 - 760	380	-	150,0	4.403,90
V.FREC/90.0	600 - 760	380	-	176,0	5.141,50

INDUCTANCIA TRIFÁSICA PARA VARIADOR

DESCRIPCIÓN

- Inductancia trifásica para salida del variador.
- Diseñada para filtrar armónicos y reducir picos de corriente, mejorando la calidad de la energía y protegiendo el variador de frecuencia contra sobretensiones y fluctuaciones en la red.



P.V.P

Consulte precios con nuestro dpto. comercial

FILTRO SENOIDAL PARA VARIADOR

DESCRIPCIÓN

- Dispositivo que se instala a la salida de un variador de frecuencia (VFD)
- Transformar la señal de onda PWM (modulación por ancho de pulso) en una onda senoidal pura.



P.V.P

Consulte precios con nuestro dpto. comercial

ELECTROBOMBA SOLAR PARA PISCINAS SERIE SOL-POOL

DESCRIPCIÓN

- Electrobomba solar para piscinas domésticas, spa o líquidos no corrosivos.
- Su diseño permite un **máximo rendimiento y un fácil mantenimiento.**
- **Funcionamiento AC/DC.**

MATERIALES

- Cuerpo de bomba: **Plástico**
- Difusor: **Plástico**
- Cubierta delantera motor: **Aluminio**
- Cubierta trasera motor: **Aluminio**

ÁREA DE TRABAJO

- Temperatura máx. del líquido: **60°C**
- Presión máx. carcasa: **2,5 bar**
- Autoaspirante: **Hasta 8 m**



CONTROLADOR



MODELO	P ₂		DN Ø		Nº PANELES	CAUDAL					P.V.P.
	kW	Hp	ASP.	IMP.		VDC	m ³ /h	0	5	10	
SOL-POOL/1.2	0,9	1,2	2"	2"	3 x 550W	19	15,2	11	7,5	2	1.268,80

ELECTROBOMBA SOLAR INOX SERIE SOL-INOX

DESCRIPCIÓN

- Bomba solar en acero **INOX**, ideal para tratamientos de agua, limpieza industrial o aplicaciones domésticas.
- Su tecnología basada en **MPPT** permite ajustar su funcionamiento para operar en el punto donde la producción de energía de los paneles solares es máxima.

MATERIALES

- Cuerpo de bomba: **Acero INOX**
- Rodete: **Latón**
- Difusor: **Plástico**

ÁREA DE TRABAJO

- Temperatura máx. del líquido: **60°C**
- Altura máx. aspiración: **2,5 bar**



MODELO	P ₂		DN Ø		Nº PANELES	CAUDAL								P.V.P.
	kW	Hp	ASP.	IMP.		VDC	m ³ /h	0	0,5	1	1,5	2	2,5	
SOL-INOX/0,75	0,55	0,75	1"	1"	2 x 550W	38	30,5	26	20	13	8	4	2,5	398,80

MPPT o *Seguidor del Punto de Máxima Potencia* es la tecnología que permite a las bombas solares ajustar su funcionamiento para operar en el punto donde la producción de energía de los paneles solares es máxima.

Esto se logra mediante un **algoritmo que monitorea y ajusta la carga eléctrica** para maximizar la eficiencia energética

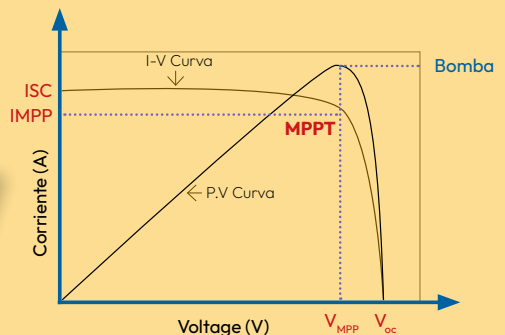

DESCRIPCIÓN

- Paneles solares fotovoltaicos con tecnología de **célula policristalina**, con una eficiencia por célula de hasta el 18,70%
- Cada módulo es sometido a los controles más estrictos, tanto ópticos como mecánicos o eléctricos, superando con éxito todos los criterios de calidad europeos.

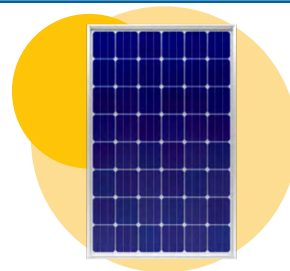

MODELO	CARACTERÍSTICAS EN CONDICIONES ESTÁNDAR (1.000 W/m ² , 25°C, A.M. 1,5)					P.V.P / WATIO
	POTENCIA DE SALIDA	VMP	IMP	VOC	ISC	
	W	V	A	V	A	
PYD330P	330	39,11	8,45	45,96	8,91	Consulte precios con nuestro dpto. comercial
PYD450P	450	41,1	10,96	49,1	11,60	
PYD550P	550	41,7	13,20	49,6	14,00	
PYD650P	650	37,9	17,16	45,0	18,39	

SELECCIÓN DE PANELES SOLARES PARA BOMBAS

POTENCIA Y TENSIÓN BOMBA	VOLTAJE PICO (VPM)	VOLTAJE MÁX. CIRCUITO ABIERTO	TIPO DE PANEL	CONEXIÓN PANELES
24 V / 120 W	≥ 30 V	< 50 V	1 x 450 W	
24 V / 250 W (para 2")	≥ 30 V	< 50 V	1 x 450 W	
36 V / 210 W (para 3")	≥ 45 V	< 100 V	2 x 450 W	
48 V / 500 W	≥ 60 V	< 100 V	2 x 450 W	
110 V / 1.000 W	≥ 112 V	< 200 V	4 x 450 W	
150 V / 1.500 W	≥ 150 V	< 250 V	5 x 450 W	
220 V / 2.200 W	≥ 220 V	< 350 V	7 x 450 W	
300 V / 3.000 W	≥ 300 V	< 420 V	8 x 450 W	



ACCESORIOS Y CUADROS PARA BOMBAS SUMERGIDAS



CONDENSADORES



CON CABLE	
CAPACITANCIA (µF)	P.V.P. ^B
8	2,42
9	2,58
10	2,65
12	2,87
14	3,25
16	3,39
18	3,54
20	3,76

CON CONECTORES FAST-ON	
CAPACITANCIA (µF)	P.V.P. ^B
20	4,08
25	4,95
30	5,67
35	6,45
40	7,01
50	8,47
60	9,88
70	11,14
80	12,52

CABLE ELÉCTRICO



TIPO Y SECCIÓN	SECCIÓN (mm)	P.V.P.*
RV-K 0,6/1 KV	3 x 1	
RV-K 0,6/1 KV	3 x 1,5	
RV-K 0,6/1 KV	3 x 2,5	
RV-K 0,6/1 KV	3 x 4	
RV-K 0,6/1 KV	3 x 6	
RV-K 0,6/1 KV	3 x 10	
RV-K 0,6/1 KV	3 x 16	
RV-K 0,6/1 KV	4 x 1,5	
RV-K 0,6/1 KV	4 x 2,5	
RV-K 0,6/1 KV	4 x 4	
RV-K 0,6/1 KV	4 x 6	
RV-K 0,6/1 KV	4 x 10	
RV-K 0,6/1 KV	4 x 16	

(*)P.V.P. Debido a la alta fluctuación del cobre solicite presupuesto antes de realizar su pedido.

CUERDA DRIZA



TIPO	GROSOR (mm)	P.V.P. ^A
Trenzada	10	0,75
Trenzada	12	0,90
Trenzada	14	1,20

EMPALME



MODELO	CABLES (mm)	P.V.P. ^A
MZ 00 EG	2 x 10 hasta 4 x 4	35,00
M 11 EG	2 x 25 hasta 4 x 16	46,00
M 12 EG	2 x 35 hasta 4 x 25	65,00

TAPA POZO



Ø (mm)	SALIDA	P.V.P. ^A
220	Roscada 1 1/4	20,80

CUADROS ELÉCTRICOS

DESCRIPCIÓN

- Cuadros de control y protección para una bomba.
- Caja estanca con **protección IP44** con interruptor manual/desconectado/automático.
- **Protección:** Protección del motor contra sobrecarga o sobreintensidad.
- **Sondas:** Control para bomba de pozo por electrosondas de nivel para motor de arranque directo. El kit de sondas se suministra sin cable. Longitud máxima del cable de sondas: 500 metros.
- **Depósito:** Mismo sistema que el cuadro por sondas, incorpora además contacto mínimo y máximo para control de nivel de agua en depósito por electrosondas. Longitud máxima del cable de sondas: **100 metros**.



MODELO (*)	TENSIÓN		POTENCIA (Hp)		INTENSIDAD (A)		P.V.P.		
	V	MÍN	MÁX	MÍN	MÁX	PROTECCIÓN	SONDAS	DEPÓSITO	
CUADRO 005 M	1~230		0,5		2,8	4,0	146,00	191,00	222,00
CUADRO 010 M	1~230		0,75	1,0	4,0	6,3	146,00	191,00	222,00
CUADRO 020 M	1~230		1,5	2,0	8,0	12,5	156,00	201,00	238,00
CUADRO 030 M	1~230			3,0	11,0	17,0	180,00	226,00	257,00

MODELO (*)	TENSIÓN		POTENCIA (Hp)		INTENSIDAD (A)		P.V.P.		
	V	MÍN	MÁX	MÍN	MÁX	PROTECCIÓN	SONDAS	DEPÓSITO	
CUADRO 005 T	3~400		0,5		1,2	1,8	160,00	198,00	206,00
CUADRO 008 T	3~400		0,75		1,8	2,0	153,00	198,00	206,00
CUADRO 010 T	3~400		1,0		1,8	2,8	153,00	208,00	229,00
CUADRO 015 T	3~400		1,5		2,8	4,0	153,00	208,00	229,00
CUADRO 030 T	3~400		2,0	3,0	4,0	6,3	153,00	208,00	229,00
CUADRO 040 T	3~400		4,0		7,0	10,0	153,00	208,00	229,00
CUADRO 055 T	3~400		5,5		8,0	12,5	163,00	219,00	240,00
CUADRO 075 T	3~400		7,5		11,0	17,0	187,00	243,00	281,00
CUADRO 125 T	3~400		10,0	12,5	15,0	23,0	222,00	267,00	304,00

Modelos "M": Monofásicos
Modelos "T": Trifásicos

CUADROS PROBOMBA

DESCRIPCIÓN

- Cuadros de tensiones 1~230V y 3~400V con **protección contra sobretensión y trabajo en seco** por rango de intensidades regulable.
- Preparado para presostato o boya en depósito.

FUNCIONAMIENTO

1. Si el relé de protección no detecta anomalías se pone en marcha el arranque.
2. Si el consumo es superior al parámetro máximo o inferior al parámetro mínimo durante más de 4 segundos, la bomba se detiene.
3. El rearme automático se intentará tres veces, en intervalos de 5-5-30 minutos, al fin de los cuales se para definitivamente, en espera de rearme manual.



RELÉ DIGITAL

MODELO	TENSIÓN		INTENSIDAD MÁXIMA	P.V.P.
	V	A		
PROBOMBA230-12	1~230	12,0	220,00	
PROBOMBA230-16	1~230	16,0	248,00	
PROBOMBA400-12	3~400	12,0	234,00	
PROBOMBA400-16	3~400	16,0	262,00	

ARRANCADORES PROGRESIVOS

DESCRIPCIÓN

- Cuadros con arrancador progresivo para una bomba con disyuntor para protección de consumo, corto circuito y sobrecarga.
- Caja estanca **protección IP44** con interruptor manual/desconectado/automático.
- **Incluye relé de nivel** controlado por electrosondas para protección contra trabajo en seco.
- Aumento gradual de la tensión de alimentación del motor mediante una rampa de arranque generada a través de semiconductores.
- La total flexibilidad obtenida, tanto en el tiempo de arranque como en la corriente y en el par motor, hace que estos arrancadores sean la solución ideal para el arranque suave en la mayoría de las aplicaciones.
- Los arrancadores están dimensionados tanto para la carga del motor como para los contactores y garantizan una fácil selección del tipo de arrancador y su instalación. Incluye relé de nivel hasta 3 sondas.



MODELO	TENSIÓN	INTENSIDAD (A)		P.V.P. ^A
	V	MÍN	MÁX	
AP-030T	3~400	4,0	6,0	1.151,00
AP-040T	3~400	6,0	10,0	1.310,00
AP-075T	3~400	9,0	14,0	1.410,00
AP-080T	3~400	13,0	18,0	1.425,00
AP-100T	3~400	17,0	22,0	1.449,00
AP-125T	3~400	20,0	25,0	1.688,00
AP-150T	3~400	25,0	32,0	1.807,00
AP-200T	3~400	9,0	30,0	1.688,00
AP-250T	3~400	14,0	45,0	2.343,00
AP-300T	3~400	18,0	60,0	2.629,00
AP-400T	3~400	24,0	80,0	2.938,00

CUADROS CONTROLBOX

DESCRIPCIÓN

- Cuadro de control o caja de control eléctrica, **con protección térmica** específicamente diseñado para motores monofásicos de bombas para pozo.
- Conexión de **cable schuko**.

MATERIALES

- Cuerpo: **Plástico resistente**
- Cable: **80 cm**



MODELO	POTENCIA		CONDENSADOR	P.V.P. ^B
	kW	HP	µF	
CONTROLBOX 055	0,55	0,75	30	37,00
CONTROLBOX 075	0,75	1,0	40	41,00
CONTROLBOX 110	1,1	1,5	45	42,00
CONTROLBOX 150	1,5	2,0	65	47,00
CONTROLBOX 220	2,2	3,0	75	57,00



INCLUYE CONDENSADOR

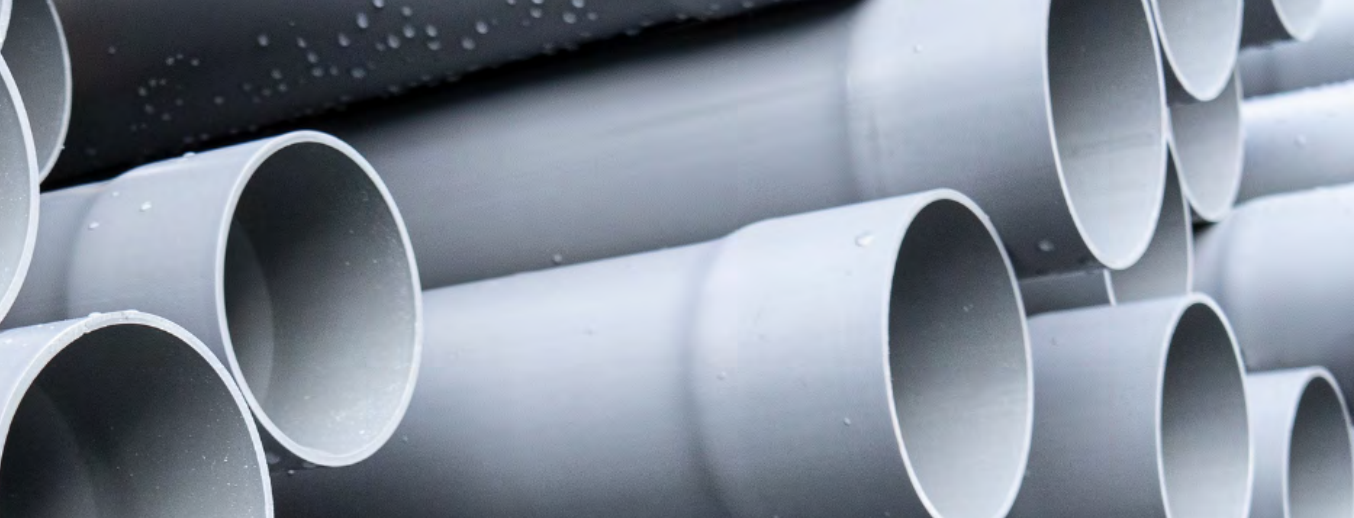

TUBERÍA UPVC



PYD
ELECTROBOMBAS

TUBERÍAS uPVC

DESCRIPCIÓN

- Rosca de tipo cuadrado:**

La unión entre tubos se realiza mediante una rosca tipo cuadrado, específicamente diseñada para asegurar un montaje rápido y una perfecta estanqueidad. Estas roscas de alta fricción no pueden abrirse a causa de la torsión ejercida por la bomba en ninguno de los sentidos.

- Relación entre espesor/roscado:**

Las roscas se construyen mediante un proceso especial, el cual consigue que, en la parte final de la rosca el tubo tenga mayor espesor. De este modo se compensa la pérdida de pared (resistencia) del extremo del tubo causado por la propia rosca, consiguiendo así una mayor resistencia a la tracción.

- Junta tórica de estanqueidad:**

La junta del extremo del tubo, así como el sistema de estanqueidad, están desarrollados para que, del mismo modo que garantizan dicha estanqueidad en el tubo, también absorban las vibraciones producidas por la bomba. De esta forma, se alarga la vida de la bomba y sus rodamientos.



MODELO	STANDARD								C	STANDARD+			C
Ø"	1	1 ¼	1 ½	2	2 ½	3	4	5		2 ½	3	4	
P (kg/cm²)	30	25	26	20	16	17	15	16		21	21	21	
P.V.P.	19,05	22,67	27,03	34,23	44,52	61,24	92,05	149,52		59,50	79,61	126,26	

MODELO	HEAVY								C	SUPER HEAVY					C
Ø"	1 ¼	1 ½	2	2 ½	3	4	5	6		2	2 ½	3	4	5	
P (kg/cm²)	35	35	27	26	26	26	26	26		35	35	35	35	35	
P.V.P.	28,09	35,80	46,94	65,99	89,59	148,18	243,01	324,36		53,39	81,25	113,13	184,16	292,95	

P.V.P.: Por tramo de 3 metros.
Las roscas de las tuberías STANDARD+, HEAVY y SUPER HEAVY son compatibles.



SISTEMA WIRELOCK

Pensado para garantizar la seguridad de su bomba sumergible. Los tramos de tubería cuentan con el **sistema Wirelock** alojado en la parte de unión con el racord.

El racord queda bloqueado con la tubería gracias a un pasador de acero inoxidable que recorre todo su perímetro asegurando que, incluso durante el proceso de desmontaje, quedan completamente fijados.



VENTAJAS

- ✓ **Vida ilimitada.** El uPVC no sufre procesos de corrosión como los metales.
- ✓ **Ligero de peso.** Un montaje más rápido, y barato.
- ✓ **Fácil de instalar.** Montaje rápido mediante accesorios roscados, abaratando los costes.
- ✓ El uPVC **no sufre procesos de electrólisis** por aguas salinas.
- ✓ **Alta resistencia a la presión y tensión.**
- ✓ El acabado totalmente liso del interior de la tubería **disminuye las pérdidas de carga** por fricción.
- ✓ **El coste del tubo es menor** que el resto de tuberías en materiales metálicos.
- ✓ **La vida del uPVC** no se ve afectada por factores meteorológicos.
- ✓ No es necesaria la utilización de juntas ni tornillos para su montaje.

ACCESORIOS

BOTTOM ADAPTADOR

- Adaptador entre la salida de la bomba (rosca GAS) y la columna de tubería (rosca de tipo cuadrado). Fabricado en **acero inoxidable AISI 204L**.
- Si la salida de la bomba no es el mismo diámetro que la tubería, consulte accesorios **REDUCCIÓN INOX** disponibles en varios diámetros.

MODELO	STANDARD								C
Ø"	1	1 ¼	1 ½	2	2 ½	3	4	5	
P.V.P.	81,10	84,55	94,30	118,50	175,40	179,15	312,35	492,00	
MODELO	STANDARD+		HEAVY		SUPER HEAVY				
Ø"	1 ¼	1 ½	2	2 ½	3	4	5	6	
P.V.P.	84,55	94,35	142,95	205,00	215,60	361,40	595,60	863,98	



TOP ADAPTADOR

- Adaptador a rosca GAS para conectar el tramo superior de tubería al resto de la instalación.
- Está disponible tanto en acero como el **acero inoxidable AISI 304L**.

MODELO	STANDARD								C
Ø"	1	1 ¼	1 ½	2	2 ½	3	4	5	
ACERO	18,60	26,75	31,25	38,65	58,20	68,95	100,65	142,65	
INOX	51,40	63,65	78,80	113,30	185,20	227,85	310,45	458,60	
MODELO	STANDARD+		HEAVY		SUPER HEAVY				
Ø"	1 ¼	1 ½	2	2 ½	3	4	5	6	
ACERO	26,75	31,25	46,00	65,75	82,15	113,18	168,95	240,78	
INOX	63,65	78,80	134,70	208,40	277,00	380,00	544,60	733,67	



REDUCCIÓN INOX

- Reducción en **acero inoxidable AISI 304L** que sustituye el **BOTTOM ADAPTOR** en caso de que la tubería sea de distinto diámetro que la salida de la bomba.
- El diámetro mayor, macho, corresponde al lado de la bomba (rosca GAS), mientras que el reducido, hembra, corresponde al lado de la tubería (rosca cuadrada).
- Este accesorio no es compatible con el **PUMP GUARD**.

MODELO	STANDARD					C
Ø"	1 ½ - 2	2 - 2 ½	2 ½ - 3	3 - 4	4 - 5	
P.V.P.	Consulte precios con nuestro dpto. comercial					
MODELO	STANDARD+		HEAVY		SUPER HEAVY	
Ø"	1 ½ - 2	2 - 2 ½	2 ½ - 3	3 - 4	4 - 5	
P.V.P.	Consulte precios con nuestro dpto. comercial					



AVISO

Estas tuberías de uPVC son autoportantes lo que significa que pueden aguantar el peso de la bomba de pozo sin necesidad de cables o soporte adicionales. No obstante, se recomienda encarecidamente que la bomba se instale con las sujeciones y accesorios adecuados para minimizar el riesgo de problemas o accidentes.

ACCESORIOS

PUMP GUARD

- Dispositivo opcional que se instala como medida de seguridad para **proteger la bomba** de desprendimientos en el pozo o fuertes vibraciones.
- Permite que, en caso de que se rompa el primer tramo de tubería (por ser el más sensible) y la bomba se quede colgando de la instalación, no caiga al fondo del pozo.
- Fabricado en **acero inox**.

MODELO	STANDARD								C
Ø"	1	1 ¼	1 ½	2	2 ½	3	4	5	
P.V.P.	58,75	72,20	75,55	121,90	147,80	178,25	240,50	338,00	
MODELO	STANDARD+		HEAVY		SUPER HEAVY				
Ø"	1 ¼	1 ½	2	2 ½	3	4	5	6	
P.V.P.	72,20	75,55	145,25	173,85	210,95	290,10	435,26	467,74	



GANCHO DE MONTAJE

- Con rosca de tipo cuadrado compatible con la tubería de uPVC para ayuda en las tareas de instalación de la columna.
- Fabricado en **fundición de hierro**.

MODELO	STANDARD								C
Ø"	1	1 ¼	1 ½	2	2 ½	3	4	5	
P.V.P.	20,15	22,10	25,50	36,30	47,35	63,90	102,75	200,20	
MODELO	STANDARD+		HEAVY		SUPER HEAVY				
Ø"	1 ¼	1 ½	2	2 ½	3	4	5	6	
P.V.P.	-	-	39,20	55,95	75,95	115,60	213,50	284,60	



TAPA POZO

- Fabricada en acero de 12 mm con diámetro interior adecuado a su instalación de tubería, ideal para hacer que la instalación descansa sobre ella.
- Nos adaptamos a las necesidades de su instalación. Solicite presupuesto para medidas personalizadas.

MODELO	DIÁMETRO	P.V.P.	C
TP300	300 mm	62,00	
TP450	450 mm	121,00	
TP600	600 mm	216,00	



LLAVE DE APRIETE NYLON

- Realice una **instalación más rápida, sencilla y barata** con la llave de apriete de nylon.
- Es una herramienta útil que le servirá en todas sus instalaciones.

MODELO	P.V.P.	C
UPVC-LLAVE-NYLON	35,00	





ELECTROBOMBAS SUMERGIDAS COMPACTAS PARA POZO



ELECTROBOMBA PERIFÉRICA SUMERGIBLE INOX 4" SERIE ONK

DESCRIPCIÓN

- Diseñadas para la distribución y elevación de aguas limpias.
- Ideal para servicios domésticos, grupos de presión y pequeños riegos.

MATERIALES

- Carcasa externa: **Acero INOX 304**
- Eje: **Acero INOX 304**
- Cuerpo bomba: **Hierro fundido niquelado**
- Impulsores: **Latón estampado**
- Motor: **Asíncrono (baño de aceite)**
- Condensador: **Incluido en el interior de la bomba**
- Retén antiarena
- Cable: **10 m**

ÁREA DE TRABAJO

- Temperatura máx. del líquido: **35°C**
- Velocidad min. de refrigeración: **0,08 m/s**
- Profundidad máx. de inmersión: **150 m**
- Arranques máx. por hora: **30 (con intervalos)**
- Grado de protección: **IP68**
- Aislamiento clase: **F**
- Trabajo horizontal: **Admitido**



		CAUDAL									
m ³ /h	0,3	0,6	0,9	1,2	1,5	1,8	2,1	2,4	2,7		
l/min	5	10	15	20	25	30	35	40	45		

MODELO	DN	P ₂		I (A)	L	PESO	CAUDAL										P.V.P.* A
	ø"	kW	Hp	1~230V	mm	Kg	ALTURA DE CARGA EN METROS										MONOF.
ONKM075	1	0,55	0,75	4,3	435	12,5	45	41	36	31	26	21	16	11	5	511,00	
ONKM100	1	0,75	1,0	5,8	460	13,0	63	49	42	37	30	23	16	10	6	521,60	
ONKM150	1	1,1	1,5	7,9	530	15,0	102	78	67	58	48	37	25	15	7	539,40	

(*) Condensador incluido en el P.V.P.

ELECTROBOMBA PERIFÉRICA SUMERGIBLE INOX 4" SERIE ACUASUB

DESCRIPCIÓN

- Bomba sumergible centrífuga multicelular de impulsores radiales.
- Diseñada para trasegar agua limpia en riego, elevaciones de agua, vaciado de depósitos, etc.

MATERIALES

- Rejilla: **Acero INOX 304**
- Eje: **Acero INOX 420**
- Cuerpo bomba: **Acero INOX 304**
- Impulsores y difusores: **Polipropileno reforzado**
- Separadores: **Polipropileno reforzado**
- Motor: **Asíncrono (baño de aceite)**
- Cierre mecánico: **Alum/Graf**
- Condensador: **Externo incluido**
- Cable: **1,5 m**

ÁREA DE TRABAJO

- Protección térmica incorporada
- Temperatura máx. del líquido: **35°C**
- Profundidad máx. de inmersión: **17 m**
- Arranques máx. por hora: **40**
- Aislamiento clase: **F**
- Contenido máx. de arena: **60 g/m3**
- Trabajo horizontal: **Admitido**



INCLUYE CONDENSADOR



		CAUDAL								
m ³ /h	0,6	1,2	1,8	2,4	2,7	3,6	4,8	5,4		
l/min	10	20	30	40	45	60	80	90		

MODELO	DN	P ₂		I (A)	COND.	L	PESO	CAUDAL										P.V.P. A	
	ø"	kW	Hp	1~230V	3~400V	µF	mm	Kg	ALTURA DE CARGA EN METROS										MONOF.
ACUASUB 55/100	1 ¼	0,75	1,0	7,0	2,8	25	751	13,0	87,7	74,2	56,1	35,9	25,8			640,00	622,00		
ACUASUB 55/140	1 ¼	1,1	1,5	9,0	3,5	40	973	14,0	118,7	101	77	49,9	36,2			756,00	738,00		
ACUASUB 70/100	1 ¼	0,75	1,0	7,0	2,8	25	632	13,0	67	65,7	62,2	57,3	55	42,8	21,9	8,7	579,00	561,00	
ACUASUB 100/100	1 ¼	1,1	1,5	9,0	3,5	40	802	15,0	89,6	86,4	81,7	75,4	71,5	56,8	29,2	11,5	666,00	648,00	

ELECTROBOMBA SUMERGIBLE INOX 5" SERIE SUB

DESCRIPCIÓN

- Bombas sumergibles centrífugas multicelulares de construcción monobloc para trasiego de aguas limpias en riego, elevaciones de agua, vaciado de depósitos, etc.
- Rejilla en la aspiración para evitar la entrada de sólidos con diámetro mayor de 2 mm.
- **Doble cierre mecánico con cámara de aceite interpuesta.**
- Los modelos monofásicos incluyen **controlbox con condensador y protección térmica.**

MATERIALES

- Carcasa externa: **Acero INOX 304**
- Rejilla: **Acero INOX 304**
- Eje: **Acero INOX 304**
- Cuerpo bomba: **Acero INOX 304**
- Impulsores: **Acero INOX 304**
- Difusores: **Acero INOX 304**
- Doble cierre mecánico: **Sic-Sic/Carb-Cer**
- Cable: **15 m**

ÁREA DE TRABAJO

- Temperatura máx. del líquido: **35°C**
- Profundidad máx. de inmersión: **20 m**
- Grado de protección: **IP68**
- Aislamiento clase: **F**
- Contenido máx. de arena: **60 g/m3**
- Diámetro mín. del pozo: **132 mm**
- Servicio continuo **S1**



CONTROLBOX INCLUIDO

IMPULSORES Y DIFUSORES INOX



MODELO	DN Ø"	P ₂ kW	I (A) Hp	COND. µF	L mm	PESO Kg	CAUDAL									P.V.P	A		
							ALTURA DE CARGA EN METROS											MONOF.	TRIF.
							0	1	1,5	2	2,5	3	3,5	4	4,5				
SUB203	1½	0,55	0,75	3,5	-	20	401	14,8	33	31	29,5	27,5	25	22	19	16	12	529,00	-
SUB204	1½	0,55	0,75	4,1	-	20	425	15,4	44	41,5	39,5	36,5	33,5	29,5	25,5	21	16	563,00	-
SUB205	1½	0,75	1,0	5,0	-	20	473	17,8	53	49,5	47	44	40	35	30	25	19	584,00	-
SUB207	1½	0,9	1,2	6,3	2,4	30	533	19,2	76,5	71	67,5	62,5	57,5	52,5	46	40	32,5	717,00	670,00
SUB208	1½	1,1	1,5	7,2	2,7	30	569	21,3	87,5	81	77	71,5	66	60	52,5	46	37	772,00	728,00

MODELO	DN Ø"	P ₂ kW	I (A) Hp	COND. µF	L mm	PESO Kg	CAUDAL											P.V.P	A		
							ALTURA DE CARGA EN METROS													MONOF.	TRIF.
							0	2,5	3	3,5	4	4,5	5	6	7	8					
SUB404	1½	0,9	1,2	6,0	2,2	25	461	18,2	43	39	38	36,5	35	33	30	25,5	19,5	13	618,00	568,00	
SUB405	1½	1,1	1,5	7,0	2,6	25	497	19,6	53	48	46,5	45	43	40	37,5	32	24	15	694,00	694,00	
SUB406	1½	1,1	1,5	7,6	2,8	30	521	20,2	66	60	58	56	54	51,5	49	42	34	20,5	722,00	666,00	
SUB407	1½	1,5	2,0	9,5	3,3	35	581	23,9	77	70	68	65,5	63	60	57	49	39,5	24	824,00	736,00	
SUB408	1½	1,5	2,0	10,5	3,8	35	605	24,5	88	80	77,5	75	72	68,5	65	56	45	27,5	839,00	760,00	

MODELO	DN Ø"	P ₂ kW	I (A) Hp	COND. µF	L mm	PESO Kg	CAUDAL										P.V.P	A		
							ALTURA DE CARGA EN METROS												MONOF.	TRIF.
							0	5	6	7	8	9	10	11						
SUB803	1½	1,1	1,5	7,0	2,6	25	467	19,6	34,5	29,5	28	26,5	24,5	22,5	20	16,5	649,00	614,00		
SUB804	1½	1,5	2,0	10,0	3,8	35	533	22,7	45,5	39	37	35	32,5	30	26,5	22,5	796,00	732,00		

ELECTROBOMBA SUMERGIBLE 5" AQUAPLUS

DESCRIPCIÓN

- Electrobomba sumergible para aguas limpias y no agresivas.
- Adecuada para aplicaciones de riego, llenado de depósitos, etc.
- Los modelos monofásicos incluyen boya de nivel y caja de conexiones con condensador.

MATERIALES

- Carcasa externa: **Acero INOX 304**
- Cuerpo de bomba: **Acero INOX 304**
- Eje: **Acero INOX 304**
- Cierre mecánico: **Cer/Grif**
- Difusores: **PPO**
- Cable: **20 m**

ÁREA DE TRABAJO

- Temperatura máx. del líquido: **35°C**
- Profundidad máx. en inmersión: **20 m**
- Grado de protección: **IP68**
- Aislamiento clase: **B**
- Servicio continuo **S1**



CONTROLBOX INCLUIDO



		CAUDAL									
m ³ /h		0	2	3	3,5	4	4,5	5	5,5	6	7,8
l/min		0	33	50	58	67	75	83	92	100	130

MODELO	DN		P ₂		I (A)		L	CAUDAL										P.V.P.	
	ø"	ø"	kW	Hp	1~230V	3~400V		mm	ALTIMETRO DE CARGA EN METROS										MONOF.
AQUAPLUS-3	1 1/4"	1 1/4"	0,55	0,75	3,82	-	480	32	28,3	27	25	23	21	19,1	15	13,1	4	326,00	-
AQUAPLUS-5	1 1/4"	1 1/4"	0,75	1,0	4,94	-	525	43,1	38	36	34	31	28	25	19	17	6	365,00	-
AQUAPLUS-6	1 1/4"	1 1/4"	1,1	1,5	7,04	-	615	65	56	54	51,2	47	42	37	28	26	10	408,00	-
AQUAPLUS-7	1 1/4"	1 1/4"	1,5	2,0	7,83	3,12	670	75	66	63,2	59	54	49	44	37	30,4	13	465,00	377,00

ELECTROBOMBA SUMERGIBLE INOX 6" SERIE 6SUB

DESCRIPCIÓN

- Electrobombas sumergibles multicelulares de acoplamiento cerrado en **acero inoxidable cromoníquel** para trasiego de aguas limpias en riego, elevaciones de agua, vaciado de depósitos.
- **Doble cierre mecánico con cámara de aceite interpuesta.** Rejilla en la aspiración para evitar la entrada de sólidos con diámetro mayor de 2 mm.
- Los modelos monofásicos incluyen boya de nivel y caja de conexiones con condensador.

MATERIALES

- Carcasa externa: **Acero INOX 304**
- Rejilla: **Acero INOX 304**
- Eje: **Acero INOX 304**
- Cuerpo bomba: **Acero INOX 304**
- Impulsores: **Acero INOX 304**
- Difusores: **Noryl**
- Cierre mecánico: **Sic/Sic - Carb/Cer**
- Cable: **15 m**

ÁREA DE TRABAJO

- Temperatura máx. del líquido: **40°C**
- Profundidad máx. de inmersión: **20 m**
- Grado de protección: **IP68**
- Aislamiento clase: **F**
- Contenido máx. de arena: **60 g/m3**
- Diámetro mín. del pozo: **170 mm**
- Servicio continuo **S1**



CONTROLBOX INCLUIDO



DOBLE CIERRE MECÁNICO



		CAUDAL									
m ³ /h		0	3	6	9	10	12	15	18	21	
l/min		0	50	100	150	167	200	250	300	350	

MODELO	DN		P ₂		I (A)		COND.	L	PESO	CAUDAL										P.V.P.	
	ø"	ø"	kW	Hp	1~230V	3~400V				μF	mm	Kg	ALTIMETRO DE CARGA EN METROS								
6SUB1002	1 1/2"	1 1/2"	1,5	2,0	10,0	3,8	35	578	25,0	33	31	29	26	25	23	20	15	9	614,00	537,00	
6SUB1003	1 1/2"	1 1/2"	2,2	3,0	14,0	5,5	50	639	30,0	49	46	43	39	38	35	30	24	15	703,00	614,00	
6SUB1004	1 1/2"	1 1/2"	3,0	4,0	-	7,2	-	706	31,0	66	62	58	53	51	47	41	32	21	-	715,00	

ELECTROBOMBA SUMERGIBLE SUBKIT

DESCRIPCIÓN

- Kit de bomba sumergible en **acero inoxidable AISI 304** para pozos.
- **Motor y accesorios ya incluidos.**
- Para aplicaciones agrícolas, domésticas e industrial, como bombeo de aguas limpias, trasvases, suministro doméstico, riego, etc.

MATERIALES

- Cuerpo de Aspiración e Impulsión: **Acero INOX 304**
- Válvula de retención: **Acero INOX 304**
- Camisa: **Acero INOX 304**
- Eje: **Acero INOX 304**
- Impulsores: **Noryl**
- Difusores: **Noryl reforzado con acero inoxidable**

EL KIT INCLUYE:

1. Electrobomba en acero INOX
2. Motor sumergible monof.
3. Cuadro
4. Cable 20/30 m (según modelo)
5. Cuerda driza de 30 m



CONTROLBOX INCLUIDO



		CAUDAL									
m ³ /h	0	1,2	1,5	1,8	2,1	2,4	2,7	3	3,6	4,2	
l/min	0	20	25	30	35	40	45	50	60	70	

MODELO	DN Ø"	P ₂		L mm	PESO Kg	CABLE m	ALTURA DE CARGA EN METROS										P.V.P. B
		kW	Hp				MONOF.										
SUBKIT-10	1½	0,55	0,75	692	13,2	20	67	61	58	54	49	43	36	28	404,00		
SUBKIT-11	1½	0,75	1,0	751	14,5	30	72	68	66	64	61	58	54	49	38	26	440,00

CONTENIDO



¡TODO INCLUIDO!



Packaging todo incluido

Electrobomba en Acero INOX

Cuadro con protección térmica

Motor sumergible 4"

Condensador

Cable del motor en 20/30 m

Cuerda driza alta resistencia disponible en 30 m

ESQUEMA DE INSTALACIÓN CON BOMBA DE POZO

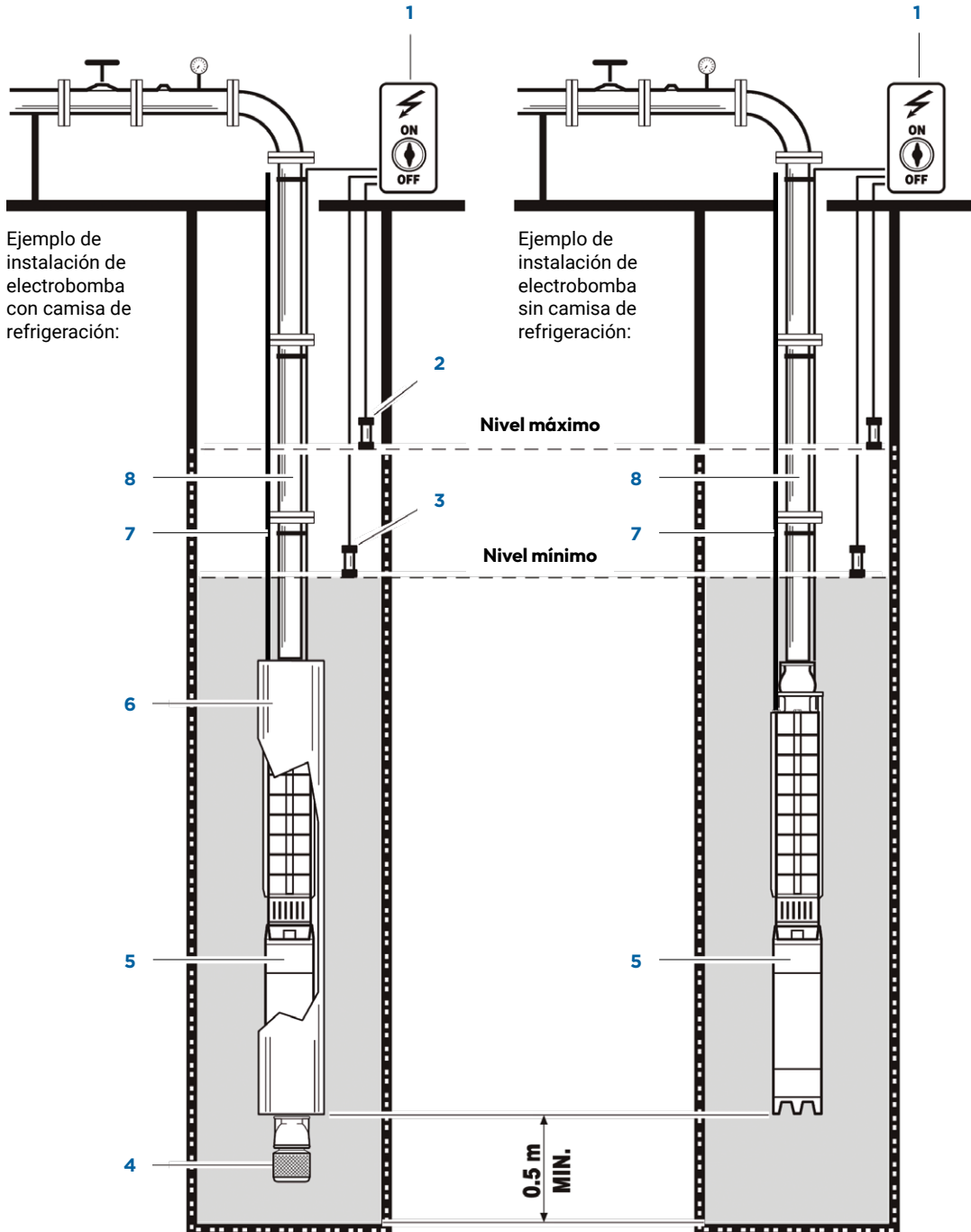

- | | | | |
|----|--|----|-----------------------------|
| 1. | Dispositivo de protección contra trabajo en seco | 5. | Motor |
| 2. | Sonda eléctrica de nivel máximo | 6. | Camisa de refrigeración |
| 3. | Sonda eléctrica de nivel mínimo | 7. | Cuerda o cable de seguridad |
| 4. | Válvula de pie | 8. | Tubería |



ACHIQUE
DRENAJE
TRITURADORAS
AGUAS RESIDUALES



ELECTROBOMBAS SUMERGIBLES SERIE AQUALITE

DESCRIPCIÓN

- Electrobomba de achique para aguas limpias de **fácil manejo**.
- El interruptor de flotador controla el encendido y apagado automático de la bomba.
- Juntas de **cojinetes de alta calidad** y **eje del motor inoxidable** con tratamiento especial que garantizan una larga vida útil.

MATERIALES

- Cuerpo de bomba: **Plástico**



ÁREA DE TRABAJO

- Temperatura máx. del líquido: **35°C**
- Grado de protección: **IPX8**
- Profundidad máx. en inmersión: **7 m**



CODO INCLUIDO



ASPIRACIÓN



**SISTEMA DE ASPIRACIÓN
GERMAN DESIGN**

		CAUDAL							
m ³ /h	0	1,2	2,4	3,6	6	8,4	9,6	10,8	
l/min	0	20	40	60	100	140	160	180	

MODELO	P ₁		DN	SÓLIDOS	PESO	ALTURA DE CARGA EN METROS								P.V.P. B	
	kW	Hp				Ø"	mm	Kg	MONOF.						
AQUALITE 450	0,45	0,6	1¼	2-3	3,7	7	6,1	5	4	1,8					75,00
AQUALITE 550	0,55	0,75	1¼	2-3	4,5	8	7,4	6,5	5,6	3,8	2	1			79,00
AQUALITE 550-S	0,55	0,75	1¼	30	4,5	7,5	6,8	5,9	5	3,5	1,9	1	0,2		77,00



+ 5000
HORAS DE TRABAJO
EN AGUAS LIMPIAS

ELECTROBOMBAS SUMERGIBLES SERIE HIPPO V

DESCRIPCIÓN

- Electro bomba potente y económica perfecta para jardines, estanques, piscinas, sistemas de riego, achique de lluvia para sótanos inundados o acuarios grandes.
- **Bajo nivel de ruido** y eficiencia energética.
- Incluye **dos bases extraíbles** para distinto paso de sólidos.

MATERIALES

- Cuerpo de bomba: **Termoplástico**
- Rejillas: **Termoplástico**
- Cierre mecánico: **Graf/Cer**



ÁREA DE TRABAJO

- Paso sólido libre: $\leq 0/30$ mm
- Temperatura máx. del líquido: **35°C**
- Grado de protección: **IPX8**
- Profundidad máx. en inmersión: **7 m**



APLICACIONES



Aguas delicadas
<1mm

Aguas limpias
<5mm

Aguas sucias
<30mm

3 FUNCIONES
1 BOMBA



2 BASES INCLUIDAS



CODO INCLUIDO

MODELO	P ₁		DN	SÓLIDOS	PESO	CAUDAL											P.V.P. B												
	kW	Hp				Ø"	mm	Kg	m ³ /h	l/min	ALTURA DE CARGA EN METROS										MONOF.								
HIPPO 250 V	0,25	0,33	1¼	0-25	3,6	0	1,2	2,4	3,6	6	8,4	9,6	12	14,4	16,8	0	20	40	60	100	140	160	200	240	280	92,00			
HIPPO 500 V	0,5	0,67	1¼	0-25	3,9	5	4,4	3,6	3,1	2	0,5	7	6,5	5,6	4,9	3,4	1,5	0,6	8,5	8	7,3	6,9	5,9	5,1	4	3	2	0,9	99,50
HIPPO 750 V	0,75	1,0	1¼	1-30	4,8																						110,80		

ELECTROBOMBAS SUMERGIBLES INOX SERIE HIPPO MAX

DESCRIPCIÓN

- Electro bomba de achique para aguas limpias de fácil manejo.
- Ideal tanto para uso doméstico (riego, jardines, piscinas) como uso industrial.

MATERIALES

- Cuerpo de bomba: **Plástico**
- Asa: **Plástico**
- Aspiración: **Acero INOX**



ÁREA DE TRABAJO

- Temperatura máx. del líquido: **35°C**
- Grado de protección: **IPX8**
- Profundidad máx. en inmersión: **8 m**



APLICACIONES



ADAPTADOR INCLUIDO

MODELO	P ₁		DN	SÓLIDOS	PESO	CAUDAL											P.V.P. B										
	kW	Hp				Ø"	mm	Kg	m ³ /h	l/min	ALTURA DE CARGA EN METROS										MONOF.						
HIPPO MAX 1000 INOX	1,0	1,3	1	0,5	9,1	0	0,9	1,9	3	4	5	5,5	6	6,6	0	16	33	50	66	83	91	100	110	240,00			
HIPPO MAX 1200 INOX	1,2	1,6	1	0,5	9,3	44	37,5	32	25	18,5	13	9	6	2,5													255,00

ELECTROBOMBAS SUMERGIBLES SERIE LKS

DESCRIPCIÓN

- Electrobomba sumergible apta para el trasiego de agua limpia o ligeramente sucia.
- Diseñada especialmente para extraer agua de pozos, piscinas o sótanos.
- Permite elegir entre una **impulsión superior o lateral/inferior**.

MATERIALES

- Envoltente, base y asa: **Polipropileno**
- Toma de impulsión: **Polipropileno**
- Impulsor: **PA6**
- Racord: **Plástico**

ÁREA DE TRABAJO

- Protector térmico
- Condensador interno
- Temperatura máx. del líquido: **35°C**
- Grado de protección: **IPX8**
- Profundidad máx. en inmersión: **7 m**



DOBLE IMPULSIÓN



ADAPTADORES INCLUIDOS

MODELO	P ₂		DN	SÓLID.	I (A)	COND.	PESO	CAUDAL								P.V.P. B																			
	kW	Hp						Ø"	mm	1~230V	µF	Kg	m ³ /h	l/min	ALTURA DE CARGA EN METROS								MONOF.												
LKS-500PA	0,5	0,7	1¼	5	1,7	10	5,7	0	1,5	3	4,5	6	8	9	10,5	12	0	25	50	75	100	133	150	175	200	8	7,7	7,3	6,4	5,5	4,5	3,3	1,9	0,4	127,00

ELECTROBOMBAS DE ACHIQUE SERIES XKS-P/PW

DESCRIPCIÓN

- **Serie P:** Aguas de filtración, pluviales. Aguas poco cargadas.
- **Serie PW:** Trasiego de aguas grises.

MATERIALES

- Envoltente, base y asa: **Polímero**
- Turbina y toma de impulsión: **Polímero**
- Eje: **Acero INOX 304**
- Retén y racord: **Plástico**
- Interruptor de nivel
- Cable: **10 m y enchufe Shcuko**

ÁREA DE TRABAJO

- Protector térmico
- Condensador interno
- Temperatura máx. del líquido: **35°C**
- Grado de protección: **IPX8**
- Profundidad máx. en inmersión: **7 m**
- Recomendable válvula de retención en impulsión



ADAPTADOR INCLUIDO

MODELO	P ₂		DN	SÓLID.	I (A)	COND.	PESO	CAUDAL								P.V.P. B																			
	kW	Hp						Ø"	mm	1~230V	µF	Kg	m ³ /h	l/min	ALTURA DE CARGA EN METROS								MONOF.												
XKS-250P	0,25	0,3	1	5	1,1	6	4,8	0	1	2	3	4	5	6	7	8,1	0	17	33	50	67	83	100	117	135	7,3	6	5	4,1	2,9	1,8	102,00			
XKS-400P	0,37	0,5	1	5	1,7	8	5,1	0	17	33	50	67	83	100	117	135	7,6	6,8	5,9	5,2	4,4	3,7	2,9	2,1	0,8	7,6	6,8	5,9	5,2	4,4	3,7	2,9	2,1	0,8	105,00
XKS-400PW	0,37	0,5	1	35	1,7	8	5,1	0	17	33	50	67	83	100	117	135	5,3	4,9	4,5	4	3,4	3	2,4	1,7	0,9	5,3	4,9	4,5	4	3,4	3	2,4	1,7	0,9	107,00

ELECTROBOMBA DE ACHIQUE SERIE AQUASMART



DESCRIPCIÓN

- Electrobomba de **multietapa con 4 impulsores**, diseñada para aguas limpias. Ideal para el trasvase de agua, sistemas de riego, y el achique de garajes o sótanos inundados.
- Incorpora un sistema electrónico que regula el **arranque y paro automático** en función de la presión y el caudal, además de **protección contra el funcionamiento en seco**.
- Con **válvula de retención** en la salida de impulsión.

MATERIALES

- Evolvente: **Acero inoxidable**
- Eje: **Acero inoxidable**
- Impulsores: **Noryl**
- Cable: **15 m**



ÁREA DE TRABAJO

- Protector térmico
- Condensador interno
- Temperatura máx. del líquido: **35° C**
- Grado de protección: **IPX8**
- Profundidad máx. de inmersión: **12 m**



VÁLVULA DE RETENCIÓN



ELECTRÓNICA INTEGRADA



AUTOMATIC START&STOP

		CAUDAL									
m ³ /h	0	1	2,5	3	3,5	4	4,5	5	5,5	6,5	
l/min	0	16,7	41,7	50	58,3	66,7	75	83,3	91,7	100	

MODELO	P ₂		DN	SÓLIDOS		I (A)	PESO	ALTURA DE CARGA EN METROS										P.V.P. B	MONOF.
	kW	Hp		Ø"	mm			1~230V	Kg	45	38,2	28	25	21,5	18,1	14,5	11		
AQUASMART 1100	1,1	1,5	1	2	4,2	7,5		45	38,2	28	25	21,5	18,1	14,5	11	7,5	1	292,00	



VÁLVULA INTEGRADA

Incluye válvula de retención en la salida de impulsión.

AUTOMATIC START & STOP

El sistema electrónico integrado monitorea continuamente la presión, activando o deteniendo automáticamente su funcionamiento.



FUNCIONAMIENTO INTELIGENTE

ELECTROBOMBA SUMERGIBLE SERIE SEA-GS INOX



DESCRIPCIÓN

- Electrobomba equipada con **doble cierre mecánico y sello de aceite** para una mayor durabilidad.
- Apta para el trasiego y drenaje de **agua marina**.
- Su motor patentado de larga duración y la entrada de **cables antihumedad** asegura un rendimiento óptimo y fiable en diversas condiciones.

MATERIALES

- Cuerpo de bomba: **Plástico**
- Aspiración: **Acero INOX**
- Cable: **10 m**

ÁREA DE TRABAJO

- Temperatura máx. del líquido: **35°C**
- Grado de protección: **IPX8**
- Profundidad máx. en inmersión: **7 m**



DOBLE CIERRE MECÁNICO



ADAPTADOR INCLUIDO

m ³ /h	CAUDAL							
	0	0,9	1,9	3	4	5	5,5	6
l/min	0	16	33	50	66	83	91	100

MODELO	P ₂		DN	SÓLIDOS	PESO	ALTURA DE CARGA EN METROS								P.V.P. B
	kW	Hp				Ø"	mm	Kg	MONOF.					
SEA-GS INOX	0,45	0,6	1	2-3	3,8	7,5	6,6	5,4	4,2	3,2	2,1	1,5	1	175,00

APTA PARA TRABAJO EN
AGUAS SALADAS



ELECTROBOMBAS DE ACHIQUE SERIES XKS-S/SW

DESCRIPCIÓN

- **Serie S:** Aguas de filtración, pluviales. Aguas poco cargadas. Con rejilla en aspiración.
- **Serie SW:** Trasego de aguas grises, instalaciones de depuración.

MATERIALES

- Envoltente, base y asa: **Acero inoxidable**
- Toma de impulsión: **Acero inoxidable**
- Eje: **Acero inoxidable**
- Tornillería: **Acero inoxidable**
- Eje: **Acero INOX 304**
- Turbina: **Termoplástico**
- Rácord: **Plástico**
- Interruptor de nivel
- Cable: **10 m y enchufe Schuko**

ÁREA DE TRABAJO

- Motor de inducción 2 polos, monofásico 220-240V/50Hz, con protector térmico.
- Condensador interno
- Paso sólido libre: $\leq 5/32$ mm
- Temperatura máx. del líquido: **35°C**
- Grado de protección: **IPX8**
- Profundidad máx. en inmersión: **7 m**
- Recomendable válvula de retención en impulsión



MODELO	P ₂		DN	SÓLIDOS		I (A)	COND.	PESO	CAUDAL										P.V.P. B									
	kW	Hp		Ø"	mm				1~230V	µF	Kg	m ³ /h	0	2	4	5,3	6	7		7,9	10	11,7	14,1	l/min	0	33	67	88
XKS-250S	0,25	0,33	1	5	1,1	6	4,6	5,2	3,2	1,6	0,7	130,00																
XKS-400S	0,37	0,5	1	5	1,7	8	5,2	7,6	6	4,7	3,6	2,7	2	1	132,00													
XKS-750SW	0,75	1,0	1	32	3,3	10	4,0	7,9	7,1	6,2	5,4	5,1	4,5	3,9	2,5	1,5	167,00											
XKS-1000SW	1,0	1,3	1	32	4,3	16	5,0	11	10	8,6	8,3	8,1	7,8	6,6	5,4	4,2	2,1	174,00										

ELECTROBOMBA DE ACHIQUE SERIE LION-150SW

DESCRIPCIÓN

- Electrobomba con cuerpo en **acero INOX** adecuada para el trasego de aguas grises, depósitos, piscinas o sótanos.

MATERIALES

- Evolvente, base y asa: **Acero inoxidable**
- Toma de impulsión: **Acero inoxidable**
- Eje: **Acero inoxidable**
- Tornillería: **Acero inoxidable**
- Impulsor y racord: **Plástico**
- Incluye interruptor de nivel
- Cable: **10 m**

ÁREA DE TRABAJO

- Protector térmico
- Condensador interno
- Paso sólido libre: ≤ 35 mm
- Temperatura máx. del líquido: **35° C**
- Grado de protección: **IPX8**
- Profundidad máx. de inmersión: **7 m**



MODELO	P ₂		DN	SÓLIDOS		I (A)	COND.	PESO	CAUDAL										P.V.P. B									
	kW	Hp		Ø"	mm				1~230V	µF	Kg	m ³ /h	0	3	4,5	6	8	9		10,5	12	14	19,5	l/min	0	50	75	100
LION-150SW	1,0	1,3	1½	35	4,2	16	8,0	10,5	9,6	9,1	8,5	8,0	7,5	6,5	6,0	5,0	0,6	209,00										

ELECTROBOMBA DE ACHIQUE SERIE TIGER INOX

DESCRIPCIÓN

- Electrobombas en **acero INOX** con **impulsor vórtex** para el bombeo de aguas residuales o aguas sucias con sólidos en suspensión.
- Adecuadas para el vaciado de pozos negros, procesamiento de aguas residuales industriales y sanitarias, etc.
- Los modelos monofásicos incluyen boya de nivel.

MATERIALES

- Cuerpo de bomba: **Acero INOX 304**
- Soporte del motor: **Acero INOX 304**
- Eje: **Acero INOX 304**
- Impulsor: **Acero INOX 304**
- Doble cierre mecánico: **Carb/Sic - Sic/Sic**
- Incluye interruptor de nivel
- Cable: **10 m**

ÁREA DE TRABAJO

- Paso sólido libre: **≤ 38 mm**
- Temperatura máx. del líquido: **40°C**
- Profundidad máx. de inmersión: **5**
- Grado de protección: **IP68**
- Aislamiento clase: **B**



DOBLE CIERRE MECÁNICO CARB/SIC-SIC/SIC



IMPULSOR



ADAPTADORES INCLUIDOS



		CAUDAL							
m ³ /h		0	3	6	9	12	15	18	21
l/min		0	50	100	150	200	250	300	350

MODELO	P ₂		DN	SÓLIDOS	I (A)	COND.	PESO	P.V.P		B	
	kW	Hp						MONOF.	TRIF.		
TIGER 75 INOX	0,55	0,75	1 1/2	38	4,0	1,5	16	14,0	9,5 8 7 6,2 5 3,8 2	385,00	385,00
TIGER 100 INOX	0,75	1,0	1 1/2	38	5,2	1,7	25	15,0	10,5 9 8 7 6 5 3,4 2	418,00	418,00

ELECTROBOMBA DE ACHIQUE SERIE TIGER INOX

DESCRIPCIÓN

- Electrobombas en **acero INOX** con **impulsor vórtex** para el bombeo de aguas residuales o aguas sucias con sólidos en suspensión.
- La forma del impulsor permite el paso libre de materiales sólidos de hasta 50 mm de diámetro.
- Los modelos monofásicos incluyen boya de nivel.

MATERIALES

- Cuerpo de bomba: **Acero INOX 304**
- Soporte del motor: **Acero INOX 304**
- Eje: **Acero INOX 304**
- Impulsor: **Acero INOX 304**
- Doble cierre mecánico: **Carb/Sic - Carb/Sic**
- Cable: **10 m**

ÁREA DE TRABAJO

- Motor de inducción 2 polos, monofásico 220 - 240V/50Hz, con protector térmico.
- Condensador interno
- Paso sólido libre: **≤ 38/50 mm**
- Temperatura máx. del líquido: **40°C**
- Profundidad máx. de inmersión: **5 m**
- Grado de protección: **IP68**
- Servicio continuo **S1**

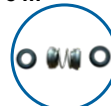

DOBLE CIERRE MECÁNICO CARB/SIC-CARB/SIC



IMPULSOR



ADAPTADORES INCLUIDOS



		CAUDAL									
m ³ /h		0	6	12	18	24	30	36	42	48	
l/min		0	100	200	300	400	500	600	700	800	

MODELO	P ₂		DN	SÓLIDOS	I (A)	COND.	PESO	P.V.P		B	
	kW	Hp						MONOF.	TRIF.		
TIGER 150 INOX	1,1	1,5	1 1/2	38	6,8	2,3	30	16,0	12,5 10,6 8 5,5 2	430,00	430,00
TIGER 200 INOX	1,5	2,0	2	50	8,6	3,2	30	19,0	14 12,5 11 9 7 4	649,00	649,00
TIGER 300 INOX	2,2	3,0	3	50	-	4,7	-	21,0	15,5 14,5 13,5 12 10,5 8,5 6,5 4,5 2,2	-	686,00

ELECTROBOMBA DE ACHIQUE SERIE BETTER-Q

DESCRIPCIÓN

- Electrobombas con **impulsor vórtex en INOX 304**.
- Diseñadas para evacuación de aguas sucias y pozos que contengan sólidos orgánicos.
- Los modelos monofásicos incluyen boya de nivel.

MATERIALES

- Cuerpo de bomba: **Acero INOX 304**
- Carcasa del motor: **ALSI 304**
- Eje: **Acero INOX 304**
- Impulsor: **Acero INOX 304**
- Doble cierre mecánico: **Carb/Sic - Sic/Sic**
- Junta tórica: **Buna-N**
- Cable: **10 m**

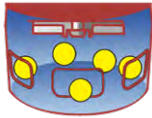

38 mm

ÁREA DE TRABAJO

- Motor de inducción 2 polos, monofásico 220-240V/50 Hz, con protector térmico.
- Condensador interno
- Paso sólido libre: **≤ 38 mm**
- Temperatura máx. del líquido: **40°C**
- Grado de protección: **IP68**
- Servicio continuo **S1**

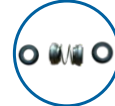

DOBLE CIERRE MECÁNICO



IMPULSOR

m ³ /h	CAUDAL							
	0	3	6	9	12	15	18	21
l/min	0	50	100	150	200	250	300	350

MODELO	P ₂		DN	SÓLIDOS	COND.	PESO	CAUDAL							P.V.P				
	kW	Hp					Ø"	mm	µF	Kg	ALTURA DE CARGA EN METROS							MONOF.
BETTER-Q-0.75BS	0,75	1,0	1½	38	25	17,0	11	9,8	8,5	7	6	5					584,00	-
BETTER-Q-1.1BS	1,1	1,5	1½	38	30	18,0	13,5	12	11	9,5	8	6	4,5	2			613,00	613,00

ELECTROBOMBA DE ACHIQUE SERIE BETTER 33

DESCRIPCIÓN

- Electrobomba para trasiego de aguas limpias o ligeramente sucias.
- Especialmente adecuadas para sótanos, garajes, tanques, fuentes, etc.

MATERIALES

- Carcasa: **Acero INOX 304**
- Bobinado: **Cobre**



ÁREA DE TRABAJO

- Protector térmico
- Paso sólido libre: **≤ 10 mm**
- Temperatura máx. del líquido: **40°C**
- Grado de protección: **IP68**
- Aislamiento clase: **F**
- Servicio continuo **S1**



DOBLE CIERRE MECÁNICO

m ³ /h	CAUDAL					
	0	1,5	3	6	7,5	9
l/min	0	25	50	100	125	150

MODELO	P ₂		DN	SÓLIDOS	COND.	PESO	CAUDAL						P.V.P		
	kW	Hp					Ø"	mm	µF	Kg	ALTURA DE CARGA EN METROS				
BETTER-33	0,25	0,33	1¼	10	6	8,0	7,8	7	6,2	5	3	2			240,00

ELECTROBOMBA DE ACHIQUE SERIE BETTER

DESCRIPCIÓN

- Electrobomba sumergible de **impulsor cerrado**.
- Diseñadas para aguas limpias o ligeramente sucias, especialmente adecuadas para sótanos, garajes, tanques, fuentes, etc.
- Los modelos monofásicos incluyen boya de nivel.

MATERIALES

- Cuerpo de bomba: **Acero INOX 304**
- Carcasa del motor: **ALSI 304**
- Eje: **Acero INOX 304**
- Impulsor: **Acero INOX 304**
- Doble cierre mecánico: **Carb/Sic - Sic/Sic**
- Junta tórica: **Buna-N**
- Cable: **10 m**



ÁREA DE TRABAJO

- Motor de inducción 2 polos, monofásico 220 - 240V/50Hz, con protector térmico.
- Condensador interno
- Paso sólido libre: **≤ 10 mm**
- Temperatura máx. del líquido: **40°C**
- Grado de protección: **IP68**
- Servicio continuo **S1**

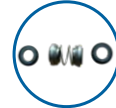

DOBLE CIERRE MECÁNICO



IMPULSOR

MODELO	P ₂		DN	SÓLIDOS	COND.	PESO	CAUDAL							P.V.P	B																			
	kW	Hp					Ø"	mm	µF	Kg	m ³ /h	l/min	0			3	6	9	12	15	18	21												
BETTER 750BS	0,75	1,0	1½	10	25	17,0	<table border="1"> <thead> <tr> <th colspan="7">ALTURA DE CARGA EN METROS</th> <th>MONOF.</th> <th>TRIF.</th> </tr> </thead> <tbody> <tr> <td>14,0</td> <td>11,8</td> <td>10</td> <td>8,5</td> <td>7</td> <td>5,2</td> <td>3</td> <td>584,00</td> <td>-</td> </tr> </tbody> </table>							ALTURA DE CARGA EN METROS							MONOF.	TRIF.	14,0	11,8	10	8,5	7	5,2	3	584,00	-			
ALTURA DE CARGA EN METROS							MONOF.	TRIF.																										
14,0	11,8	10	8,5	7	5,2	3	584,00	-																										
BETTER 1100BS	1,1	1,5	1½	10	30	18,0	<table border="1"> <thead> <tr> <th colspan="7">ALTURA DE CARGA EN METROS</th> <th>MONOF.</th> <th>TRIF.</th> </tr> </thead> <tbody> <tr> <td>16,0</td> <td>13,8</td> <td>10,2</td> <td>10,2</td> <td>9</td> <td>7</td> <td>4,8</td> <td>2</td> <td>613,00</td> <td>613,00</td> </tr> </tbody> </table>							ALTURA DE CARGA EN METROS							MONOF.	TRIF.	16,0	13,8	10,2	10,2	9	7	4,8	2	613,00	613,00		
ALTURA DE CARGA EN METROS							MONOF.	TRIF.																										
16,0	13,8	10,2	10,2	9	7	4,8	2	613,00	613,00																									

ELECTROBOMBA DE ACHIQUE SERIE BETTER 2

DESCRIPCIÓN

- Electrobomba sumergible con **impulsor cerrado**.
- Diseñadas para aguas limpias o ligeramente sucias, especialmente adecuada para sótanos, garajes, tanques, fuentes, etc.

MATERIALES

- Cuerpo de bomba: **Acero INOX 304**
- Carcasa del motor: **ALSI 304**
- Eje: **Acero INOX 304**
- Impulsor: **PPO + 20% fibra de vidrio**
- Doble cierre mecánico: **Carb/Sic - Sic/Sic**
- Junta tórica: **Buna-N**
- Cable: **10 m**



ÁREA DE TRABAJO

- Motor de inducción 2 polos, monofásico 220 - 240V/50Hz, con protector térmico.
- Condensador interno
- Paso sólido libre: **≤ 10 mm**
- Temperatura máx. del líquido: **40°C**
- Grado de protección: **IP68**
- Servicio continuo **S1**



DOBLE CIERRE MECÁNICO



IMPULSOR

MODELO	P ₂		DN	SÓLIDOS	COND.	PESO	CAUDAL						P.V.P	B														
	kW	Hp					Ø"	mm	µF	Kg	m ³ /h	l/min			0	0,6	1,2	2,4	3,6	4,8								
BETTER2-30-0,75BS	0,75	1,0	1¼	10	25	13,0	<table border="1"> <thead> <tr> <th colspan="6">ALTURA DE CARGA EN METROS</th> <th>MONOF.</th> </tr> </thead> <tbody> <tr> <td>33</td> <td>32</td> <td>31,5</td> <td>31</td> <td>30,2</td> <td>28,5</td> <td>426,00</td> </tr> </tbody> </table>						ALTURA DE CARGA EN METROS						MONOF.	33	32	31,5	31	30,2	28,5	426,00		
ALTURA DE CARGA EN METROS						MONOF.																						
33	32	31,5	31	30,2	28,5	426,00																						

ELECTROBOMBA DE ACHIQUE SERIE PANTHER

DESCRIPCIÓN

- Electrobombas sumergibles de **impulsor abierto**, fabricadas en **acero INOX 304**.
- Diseñadas para agua limpia o ligeramente sucia.
- La rejilla de succión con filtro permite un paso libre y sólidos.
- Los modelos monofásicos incluyen boya de nivel.

MATERIALES

- Cuerpo de bomba: **Acero INOX 304**
- Carcasa del motor: **Acero INOX 304**
- Eje: **Acero INOX 304**
- Impulsor: **Acero INOX 304**
- Doble cierre mecánico: **Carb/Sic - Sic/Sic**
- Junta tórica: **Buna-N**
- Cable: **10 m**



ÁREA DE TRABAJO

- Moto de inducción 2 polos, monofásico 220-240V/50Hz, con protector térmico.
- Condensador interno
- Paso sólido libre: **≤ 10 mm**
- Temperatura máx. del líquido: **40°C**
- Grado de protección: **IP68**
- Servicio continuo **S1**

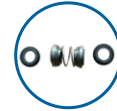

DOBLE CIERRE MECÁNICO



IMPULSOR

		CAUDAL							
m ³ /h		0	3	6	9	12	15	18	21
l/min		0	50	100	150	200	250	300	350

MODELO	P ₂		DN	SÓLIDOS	COND.	PESO	CAUDAL								P.V.P	B
	kW	Hp					Ø"	mm	µF	Kg	ALTURA DE CARGA EN METROS					
PANTHER 75	0,55	0,75	1½	10	16,0	13,0	12,5	10,8	9,5	8,5	7,5	6,5	5	373,00	373,00	
PANTHER 100A	0,75	1,0	1½	10	25,0	14,0	15	12,5	11,5	10,5	9	8	7	5,5	406,00	406,00
PANTHER 100B	0,75	1,0	1½	10	-	14,0	18	16,5	14	11,5	8,5	-	-	406,00	406,00	

ELECTROBOMBA DE ACHIQUE SERIE PANTHER

DESCRIPCIÓN

- Electrobombas sumergibles de **impulsor abierto**, fabricadas en **acero INOX 304**.
- Diseñadas para agua limpia o ligeramente sucia, especialmente adecuadas para vaciar sótanos y garajes, tanques, piscinas y fuentes.
- La rejilla de succión con filtro permite un paso libre y sólidos.
- Los modelos monofásicos incluyen boya de nivel.

MATERIALES

- Cuerpo de bomba: **Acero INOX 304**
- Carcasa del motor: **Acero INOX 304**
- Eje: **Acero INOX 304**
- Impulsor: **Acero INOX 304**
- Doble cierre mecánico: **Carb/Sic - Sic/Sic**
- Junta tórica: **Buna-N**
- Cable: **10 m**



ÁREA DE TRABAJO

- Motor de inducción 2 polos, monofásico 220 - 240V/50Hz, con protector térmico.
- Condensador interno
- Paso sólido libre: **≤ 10 mm**
- Temperatura máx. líquido: **40°C**
- Grado de protección: **IP68**
- Servicio continuo **S1**



DOBLE CIERRE MECÁNICO



IMPULSOR

		CAUDAL								
m ³ /h		0	6	12	18	24	30	36	42	48
l/min		0	100	200	300	400	500	600	700	800

MODELO	P ₂		DN	SÓLIDOS	COND.	PESO	CAUDAL										P.V.P	B
	kW	Hp					Ø"	mm	µF	Kg	ALTURA DE CARGA EN METROS							
PANTHER 150	1,1	1,5	2	10	30	16,0	13,5	12,5	11	9	7	4,5	430,00	430,00				
PANTHER 200	1,5	2,0	2	10	30	18,0	13,9	13	11,5	9,6	7	4,5	649,00	649,00				
PANTHER 300	2,2	3,0	3	10	-	20,0	17,5	17	16	14,5	13,6	11,7	9	7	4,2	-	686,00	

ELECTROBOMBA SUMERGIBLE SERIE V

DESCRIPCIÓN

- Electrobombas de **fabricación robusta y larga duración**, pensadas para un trabajo diario de elevación de aguas negras, fecales o con residuos orgánicos en suspensión.
- **Sistema vórtex** que permite el paso libre de sólidos, minimizando así el riesgo de atasco.
- Los modelos monofásicos incluyen boya de nivel.

MATERIALES

- Cuerpo de bomba: **Fundición**
- Envolvente del motor y asa: **Acero INOX**
- Impulsor: **Fundición de hierro**
- Interruptor de nivel: **Con 30 cm de cable** (modelos monofásicos)
- Doble cierre mecánico: **Carb/Sic**
- Cable: **5 m**



ÁREA DE TRABAJO

- Paso sólido libre: **≤ 25 mm**
- Temperatura máx. del líquido: **35°C**
- Profundidad máx. de inmersión: **5 m**
- Grado de protección: **IP68**
- Aislamiento clase: **F**



MODELO	P ₂		DN SÓLIDOS		I (A)		PESO	CAUDAL								P.V.P		B																		
	kW	Hp	mm	mm	1~230V	3~400V		Kg	m ³ /h	l/min	ALTURA DE CARGA EN METROS								MONOF.	TRIF.																
V450	0,45	0,6	50	25	4,3	-	18,5	0	2	4	8	12	16	18	20	22	0	33	67	133	200	270	300	333	366	7,7	6,7	6,3	5,5	4,3	2,7	212,00	-			
V750	0,75	1,0	50	25	5,2	1,8	19,5	0	2	4	8	12	16	18	20	22	0	33	67	133	200	270	300	333	366	9,4	8,8	8,6	8,5	8	6,8	5,9	5,1	4,2	244,00	254,00

ELECTROBOMBA SUMERGIBLE SERIE V

DESCRIPCIÓN

- Electrobombas de **fabricación robusta y larga duración**, pensadas para un trabajo diario de elevación de aguas negras, fecales o con residuos orgánicos en suspensión.
- **Sistema vórtex** que permite el paso libre de sólidos, minimizando así el riesgo de atasco.
- Los modelos monofásicos incluyen boya de nivel.

MATERIALES

- Cuerpo de bomba: **Fundición**
- Envolvente del motor y asa: **Acero INOX**
- Impulsor: **Fundición de hierro**
- Interruptor de nivel: **Con 30 cm de cable** (modelos monofásicos)
- Doble cierre mecánico: **Carb/Sic**
- Cable: **10 m**



ÁREA DE TRABAJO

- Paso sólido libre: **≤ 25 mm**
- Temperatura máx. del líquido: **35°C**
- Profundidad máx. de inmersión: **5 m**
- Grado de protección: **IP68**
- Aislamiento clase: **F**



MODELO	P ₂		DN SÓLIDOS		I (A)		PESO	CAUDAL								P.V.P		B																		
	kW	Hp	mm	mm	1~230V	3~400V		Kg	m ³ /h	l/min	ALTURA DE CARGA EN METROS								MONOF.	TRIF.																
V1100	1,1	1,5	50	35	7,2	2,5	23,5	0	2	4	8	12	16	18	20	22	0	33	67	133	200	270	300	333	366	11,3	11	10,8	9,9	8,9	7,3	6,7	6	5	275,00	283,00

ELECTROBOMBA SUMERGIBLE SERIE V

DESCRIPCIÓN

- Electrobomba especialmente diseñada para el trasiego de aguas turbias sin fibras y provenientes de recogida de agua de lluvia, filtración, etc.
- Orientada a uso tanto doméstico como agrícola.
- Los modelos monofásicos incluyen boya de nivel.

MATERIALES

- Cuerpo de bomba: **Fundición**
- Envolvente del motor y asa: **Acero INOX**
- Rejilla de aspiración: **Acero INOX**
- Impulsor: **Fundición de hierro**
- Doble cierre mecánico: **Carb/Sic (con cámara de aceite interpuesta)**
- Cable: **10 m**



ÁREA DE TRABAJO

- Temperatura máx. del líquido: **35°C**
- Profundidad máx. de inmersión: **5 m**
- Grado de protección: **IP68**
- Aislamiento clase: **F**



MODELO	P ₂		DN SÓLIDOS		I (A)		PESO	CAUDAL											P.V.P.	B										
	kW	Hp	mm	mm	1~230V	3~400V		Kg	m ³ /h	0	4	8	10	15	18	22	29	35			40	43	l/min	0	67	133	167	250	300	417
V1500	1,5	2,0	50	10	9,4	3,4	26,8	ALTURA DE CARGA EN METROS											MONOF.	TRIF.										
								21,7	18,5	17,5	15,7	12,3	8,9	5,3	336,00	352,00														
V2200	2,2	3,0	75	20	-	4,7	32,3	ALTURA DE CARGA EN METROS											-	380,00										
								19,6	19	17,8	17,5	16	15,1	13,9	10,8	8,2	5,5	2,7	-	380,00										

ELECTROBOMBA SUMERGIBLE TRITURADORA SERIE V1300

DESCRIPCIÓN

- Electrobomba sumergible para tensión monofásica con **tritador**.
- Diseñada específicamente para achique de aguas residuales.
- Equipada con una **cuchilla rotatoria de alta velocidad** en la entrada de la bomba que corta y tritura sólidos filamentosos y/o residuos diversos encontrados en las aguas fecales, evitando que el impulsor quede bloqueado.

MATERIALES

- Cuerpo de bomba: **Fundición**
- Envolvente del motor: **Acero INOX**
- Eje: **Acero INOX 304**
- Impulsor: **Fundición de hierro**
- Doble cierre mecánico: **Carb/Sic (con cámara de aceite interpuesta)**
- Cable: **10 m**



ÁREA DE TRABAJO

- Temperatura máx. del líquido: **40°C**
- Profundidad máx. de inmersión: **5 m**
- Grado de protección: **IP68**



MODELO	P ₂		DN	I (A)	PESO	CAUDAL											P.V.P.	B				
	kW	Hp				mm	1~230V	Kg	m ³ /h	0	3	8	10	13	16	19			24	l/min	0	50
V1300	1,3	1,75	50	7,5	25,0	ALTURA DE CARGA EN METROS											MONOF.					
						15,4	14,6	13,2	12,5	11,4	10,1	8,6	6	325,00								

ELECTROBOMBA DE ACHIQUE INOX SERIE DUMPER

DESCRIPCIÓN

- Electrobombas sumergibles útiles para el drenaje de áreas inundadas como sótanos, garajes subterráneos, etc.
- Adecuadas para el manejo de aguas residuales y el vaciado de pozos de aguas negras.
- Los modelos monofásicos incluyen boya de nivel.

MATERIALES

- Cuerpo de bomba: **Acero INOX**
- Envoltorio del motor: **Acero INOX**
- Eje: **Acero INOX 316**
- Impulsor: **Acero INOX**
- Doble cierre mecánico: **Carb/Sic (con cámara de aceite interpuesta)**
- Cable: **5 m**



ÁREA DE TRABAJO

- Temperatura máx. del líquido: **40°C**
- Profundidad máx. de inmersión: **5 m**
- Grado de protección: **IP68**
- Aislamiento clase: **B**
- Servicio continuo **S1**



ADAPTADOR INCLUIDO



MODELO	P ₂		DN SÓLID.		I (A)			COND. PESO		CAUDAL										P.V.P		B																	
	kW	Hp	Ø"	mm	1~230V	3~400V	µF	Kg	ALTURA DE CARGA EN METROS										MONOF.	TRIF.																			
DUMPER 80	0,55	0,75	2	10	4,1	-	20	16,0	0	2	4	6	8	12	14	16	18	20	0	33	67	100	133	200	233	267	300	333	10,2	9,9	9,2	8,5	7,8	6,0	4,8	3,6	2,4	324,70	-
DUMPER 100	0,75	1,0	2	10	5,2	2,0	30	18,0	0	33	67	100	133	200	233	267	300	333	15,0	14,5	13,8	13,1	12,3	9,6	8,4	6,6	5,1	3,2	380,60	339,80									

ELECTROBOMBA DE ACHIQUE SERIE TIGER

DESCRIPCIÓN

- Electrobombas sumergibles con **impulsor vórtex** para achique de líquidos conteniendo barro, arena, fibras cortas, desechos de papel y otras partículas sólidas, así como sólidos blandos, aguas residuales, aguas grises, etc.
- Los modelos monofásicos incluyen condensador e interruptor de nivel.

MATERIALES

- Cuerpo de bomba: **Fundición**
- Envoltorio del motor: **Acero INOX**
- Eje: **Acero INOX 304**
- Doble cierre mecánico: **Sic/Cer - Carb/Cer (con cámara de aceite interpuesta)**
- Cable: **8 m**



ÁREA DE TRABAJO

- Temperatura máx. del líquido: **40°C**
- Profundidad máx. de inmersión: **10 m**
- Grado de protección: **IP68**
- Aislamiento clase: **B**



ADAPTADOR INCLUIDO



MODELO	P ₂		DN SÓLID.		I (A)			COND. PESO		CAUDAL								P.V.P		B												
	kW	Hp	Ø"	mm	1~230V	3~400V	µF	Kg	ALTURA DE CARGA EN METROS								MONOF.	TRIF.														
TIGER 150	1,1	1,5	2	35	7,2	2,8	30	20,0	0	4	8	12	16	20	24	28	0	67	133	200	267	333	400	466	14	12,5	11	9,5	7,9	5,9	389,00	369,00
TIGER 200	1,5	2,0	2	35	10,0	3,2	35	22,0	0	67	133	200	267	333	400	466	18	16	15	13	11,8	10	8,5	5,8	438,00	450,00						

ELECTROBOMBAS DE ACHIQUE SERIE TIGER-MAX



DESCRIPCIÓN

- Electrobombas sumergibles con **impulsor vórtex** para achique de líquidos conteniendo barro, arena. Especialmente útiles para el bombeo de aguas residuales que contienen partículas de gran tamaño de obras de construcción y minas.
- Los modelos monofásicos incluyen condensador e interruptor de nivel.

MATERIALES

- Cuerpo de bomba: **Fundición**
- Envoltante del motor: **Acero INOX**
- Eje: **Acero INOX 304**
- Doble cierre mecánico: **Sic/Sic - Carb/Cer (con cámara de aceite interpuesta)**
- Cable: **8 m**

ÁREA DE TRABAJO

- Temperatura máx. del líquido: **40°C**
- Profundidad máx. de inmersión: **10 m**
- Grado de protección: **IP68**
- Aislamiento clase: **F**

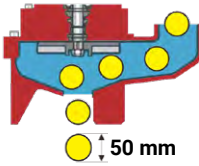

CODO EMBRIDADADO DISPONIBLE



ZÓCALO DISPONIBLE

MODELO	P ₂		DN	SÓLIDOS		I (A)	COND.		PESO	CAUDAL						P.V.P		B			
	kW	Hp		mm	mm		μF	Kg		m ³ /h	l/min	ALTURA DE CARGA EN METROS				MONOF.	TRIF.				
	1~230V	3~400V					0	5	10	15	20	25	30	0	83,3	166,7	250	333,3	416,7	500	
TIGER-MAX100	0,75	1,0	2	50	5,2	2,0	20	21	11	9,4	8	6,6	5,1	333,10	320,30						
TIGER-MAX150	1,1	1,5	2	50	7,2	2,8	30	22,5	13	11,5	9,8	8	6,7	5	388,60	371,50					
TIGER-MAX200	1,5	2,0	2	50	10,0	3,2	35	25	15	14,9	12,5	11	9,8	8,1	6	452,60	439,80				



PASO DE SÓLIDOS
50 mm

CODO INCLUIDO

Equipada con un codo roscado de salida 1 1/2" y espiga.
Codo embridado disponible (pág. 103)

ELECTROBOMBA DE ACHIQUE SERIE WQ

DESCRIPCIÓN

- Electrobombas de achique de gran resistencia.
- Con **impulsor vórtex** situado fuera de la voluta, permitiendo el paso libre de sólidos.
- Motor trifásico con **protección térmica** para proteger contra cortocircuito, sobrealimentación, sobrecarga y sobrecalentamiento.

MATERIALES

- Cuerpo de bomba: **Fundición**
- Envolvente del motor: **Fundición**
- Impulsor: **Hierro dúctil**
- Eje: **Acero inoxidable**
- Doble cierre mecánico: **Sic/Carb-Cer**
- Cable: **8 m**

ÁREA DE TRABAJO

- Temperatura máx. del líquido: **35°C**
- Profundidad máx. de inmersión: **10 m**
- Densidad máx. del líquido: **1,3 g/cm³**
- Grado de protección: **IP68**
- Aislamiento clase: **F**
- Servicio continuo

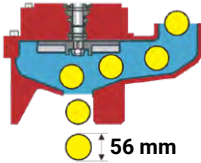

		CAUDAL						
m ³ /h	0	10	20	30	40	50	60	70
l/min	0	167	333	500	667	833	1000	1167

MODELO	P ₂		DN	SÓLID.	ACOPLE	I (A)	PESO	ALTURA DE CARGA EN METROS							P.V.P. C			
	kW	Hp						Ø	mm	TIPO	3~400V	Kg	TRIF.					
65WQ25-10	2,2	3,0	65	56	65-65	5,0	39,0	16	13,8	11,5	9,3	6,8					634,00	
65WQ25-15	3,0	4,0	65	56	65-65	6,5	48,0	20	18	16	13,5	11					792,00	
80WQ40-15	4,0	5,5	80	56	80-80	8,9	56,0	21	19	16,5	14,5	12	8,5	5			995,00	
80WQ50-15	5,5	7,5	80	56	80-80	11,7	73,0	23	21	18,5	16,8	14,5	12	9	5			1.259,00

ELECTROBOMBA DE ACHIQUE SERIE U

DESCRIPCIÓN

- Electrobombas de achique de gran resistencia.
- El impulsor de **tipo vórtex** permite un gran paso de sólidos y el cierre mecánico está diseñado para ofrecer una gran resistencia al desgaste.

MATERIALES

- Cuerpo de bomba: **Fundición**
- Envolvente del motor: **Fundición**
- Eje: **Acero INOX 304**
- Impulsor: **Hierro dúctil**
- Doble cierre mecánico: **Sic/ Sic**
- Cable: **8 m**

ÁREA DE TRABAJO

- Temperatura máx. del líquido: **35°C**
- Profundidad máx. de inmersión: **20 m**
- Agua química y mecánicamente: **No agresiva**
- Grado de protección: **IP68**
- Aislamiento clase: **F**
- Servicio continuo

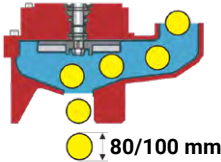

		CAUDAL						
m ³ /h	0	30	60	93	109	118	149	175
l/min	0	500	1000	1550	1817	1967	2484	2917

MODELO	P ₂		DN	SÓLID.	ACOPLE	I (A)	PESO	ALTURA DE CARGA EN METROS							P.V.P. C			
	kW	Hp						ø"	mm	TIPO	3~400V	Kg	TRIF.					
80U45.5	5,5	7,5	80	80	80-80	11,7	132,0	15	14	12	7					1.981,00		
100U45.5	5,5	7,5	100	100	100-100	11,7	136,0	13	12	10	8	7	5				1.981,00	
80U47.5	7,5	10	80	80	80-80	15,7	147,0	17	16	15	13	12					2.298,00	
100U47.5	7,5	10	100	100	100-100	15,7	151,0	15	14	13	11	10	9	7,5			2.298,00	
100U411	11	15	100	100	100-100	22,0	170,0	18	17	16	14	14	13,5	12	9			2.549,00

ELECTROBOMBA SUMERGIBLE SERIE SEMISON

DESCRIPCIÓN

- Electrobombas de drenaje con rejilla o de rodete centrífugo de tipo bicanal.
- Especialmente diseñadas para el trasiego de aguas residuales, fosas sépticas con sólidos en suspensión y procesos biológicos.

MATERIALES

- Cuerpo de bomba y soporte: **Fundición**
- Envolvente del motor: **Acero INOX**
- Impulsor: **Fundición**
- Envolvente de motor y asa: **Acero INOX 304**
- Eje: **INOX 420**
- Cable: **10 m (5 m en Series 465, 635)**

ÁREA DE TRABAJO

- Temperatura máx. del líquido: **40°C**
- Profundidad máx. de inmersión: **10 m**
- Grado de protección: **IP68**
- Aislamiento clase: **F**

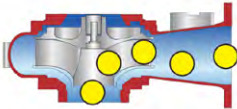

5/32/50/65 mm

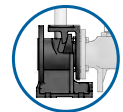

ZÓCALO DISPONIBLE

MODELO	P ₂		DN		SÓLID.		I (A)		CON.	PESO	CAUDAL								P.V.P	
	kW	Hp	Ø"	mm	1~230V	3~400V	µF	Kg			ALTURA DE CARGA EN METROS								MONOF.	TRIF.
											1,8	6	9	12	15	18	21	24		
SEMISOM 465	1,1	1,5	2	5	7,3	2,7	20	19,5	18,5	17,5	16,5	15,5	14	12	9,5	6,5	1	743,40	708,40	

Semison 465: Modelo con base de rejilla (aspiración).

MODELO	P ₂		DN		SÓLID.		I (A)		CON.	PESO	CAUDAL								P.V.P	
	kW	Hp	Ø"	mm	1~230V	3~400V	µF	Kg			ALTURA DE CARGA EN METROS								MONOF.	TRIF.
											1,8	6	12	15	18	24	27	30		
SEMISOM 635	1,1	1,5	2	32	7,3	2,7	20	21,8	14,5	13,5	12	11	10	7,5	6,5	5	0,5	789,00	754,00	

MODELO	P ₂		DN		SÓLID.		ACOPLE		I (A)		CON.	PESO	CAUDAL									P.V.P	
	kW	Hp	Ø"	mm	Tipo	1~230V	3~400V	µF	Kg	ALTURA DE CARGA EN METROS									MONOF.	TRIF.			
										6			12	24	30	36	48	60			66	90	
SEMISOM 700	1,1	1,5	2	50	50	9,2	3,3	40	31,0	13	11,5	8,5	7,0	5	1	1.399,20	1.241,40						
SEMISOM 900	1,5	2,0	2 ½	50	50	11,4	4,0	45	31,0	15	14	11,5	10	8	5	0,5	1.521,90	1.357,10					
SEMISOM 1000	2,2	3,0	2 ½	50	50	-	5,9	-	35,0	19,5	18,0	15,5	14	12	8,5	4	1,5	-	1.507,90				
SEMISOM 1500	3,4	4,5	3	65	65	-	9,0	-	44,0	18,5	17,5	15,5	14,5	13,5	11,0	8,5	7	1,5	-	1.879,60			

Disponible dispositivo de descenso y anclaje automático. Consulte con nuestro dpto. técnico

ELECTROBOMBA TRITURADORA SERIE TR

DESCRIPCIÓN

- Electrobombas trituradoras especialmente diseñadas para el trasiego de aguas cargadas con residuos orgánicos en suspensión.
- La solución perfecta en caso de estrechamiento de tuberías.
- Con gran capacidad para triturar plástico, látex, materiales textiles, etc.

MATERIALES

- Cuerpo de bomba: **Hierro fundido + G20**
- Eje: **DIN EN c45/55-420**
- Doble cierre mecánico: **Sic/Sic**

ÁREA DE TRABAJO

- Temperatura máx. del líquido: **40°C**
- Grado de protección: **IP68**
- Aislamiento clase: **B**

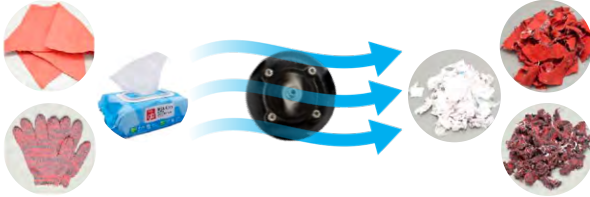

		CAUDAL									
		m ³ /h	0	2	4	5	6	8	10	11	16
		l/min	0	33	67	83	100	133	167	183	267

MODELO	P ₂		DN	PESO	CAUDAL										P.V.P.			
	kW	Hp			Ø"	Kg	ALTURA DE CARGA EN METROS										MONOF.	TRIF.
TR-0,75	0,55	0,75	2	14,5	7	6,3	5,5	5	4,5	2,9	1						265,00	245,00
TR-1,5	1,1	1,5	2	18,0	10	9,5	9	8,5	8,2	7,5	6,7	6,2	2,9				285,00	265,00

ELECTROBOMBA TRITURADORA SERIE DTRT

DESCRIPCIÓN

- Electrobomba trituradora diseñada para el trasiego de aguas cargadas con residuos orgánicos en suspensión. Permite su uso en aplicaciones móviles o fijas con pie de acoplamiento.
- El sistema triturador permite el bombeo de aguas sucias con fibras textiles o filamentosas, líquidos industriales, civiles o zootécnicos, donde se necesita triturar cuerpos sólidos en suspensión.

MATERIALES

- Cuerpo de bomba: **Fundición**
- Eje: **Acero INOX 304**
- Impulsor: **Fundición**
- Doble cierre mecánico: **Carb/SiC - Cer/Graf**
- Triturador: **Acero tratado**
- Cable: **10 m**

ÁREA DE TRABAJO

- Temperatura máx. del líquido: **40°C**
- Profundidad máx. de inmersión: **20 m**
- Grado de protección: **IPX8**
- Aislamiento clase: **F**



		CAUDAL									
		m ³ /h	0	3	6	9	12	15	18	21	21,6
		l/min	0	50	100	150	200	250	300	350	360

MODELO	P ₂		P ₁	DN	I (A)	PESO	CAUDAL										P.V.P.							
	kW	Hp					W	mm	3~400V	Kg	ALTURA DE CARGA EN METROS										TRIF.			
DTRT 550	4,0	5,5	5.300	50	9,2	65,5	38,6	36,9	35,3	33,9	32,1	30,1	27,6										2.487,00	
DTRT 750	5,5	7,5	8.000	65	13,9	91,5	47,8	46,2	44,5	42,7	40,8	38,9	36,1	26,7	11									3.045,00
DTRT 1000	7,5	10	9.100	65	15,5	94,5	54,6	52,7	51	49,2	47,1	45,1	42,7	34	15									3.077,00

ELECTROBOMBA TRITURADORA SERIE TRITÓN



DESCRIPCIÓN

- La serie **TRITÓN** de electrobombas sumergibles representa la vanguardia en eficiencia para el manejo de aguas residuales en el mercado actual. Diseñadas para **triturar sin esfuerzo** materiales como tejidos y plásticos de baja densidad, estas bombas son una opción económica y efectiva para el bombeo de aguas residuales a través de tuberías de diámetro reducido, tanto en entornos domésticos como industriales.
- Las redes municipales de alcantarillado presurizado suponen una alternativa económica a la evacuación de aguas residuales por gravedad que favoreciendo así la protección medioambiental.
- Los modelos monofásicos incluyen interruptor de nivel.

MATERIALES

- Cuerpo de bomba: **Fundición**
- Eje: **Acero INOX**
- Impulsor: **Acero INOX**
- Doble sello mecánico: **Carb/Sic**
- Cable: **8 m**

ÁREA DE TRABAJO

- Temperatura máx. del líquido: **40°C**
- Profundidad máx. de inmersión: **5 m**
- Grado de protección: **IP68**
- Aislamiento clase: **F**
- Servicio continuo



INTERRUPTOR DE NIVEL EN MONOF.



IMPULSOR



TRITURADOR



		CAUDAL												
m ³ /h		0	4	16	20	24	36	40	48	56	66	88	104	128
l/min		0	67	267	333	400	600	667	800	933	1100	1466	1733	2133

MODELO	P ₂		DN	I (A)		CAUDAL												P.V.P.							
	kW	Hp		mm	1~230V	3~400V	ALTURA DE CARGA EN METROS												MONOF.	TRIF.					
TRITÓN10-10*	0,75	1,0	40	4,1	1,9	14	13	7	2									481,00	466,00						
TRITÓN12-10*	1,1	1,5	40	4,5	2,0	16	15	8,5	4	2									498,00	446,00					
TRITÓN15-15*	1,5	2,0	50	7,9	3,2	21	19	14	12	10	2									724,00	645,00				
TRITÓN25-15	2,2	3,0	65	-	4	22	21	17,5	16	15,5	11	10	7	2									-	710,00	
TRITÓN35-15	3,0	4,0	50	-	5,5	24	23,5	22,5	21,2	20	14	11,5									-	831,00			
TRITÓN45-17	4,0	5,5	65	-	8,4	30	29	26	24	23	21,2	18	14,8	12	8									-	937,00
TRITÓN20-40	7,5	10	50	-	15,7	56	55	51	48	46	39	37	32	27									-	1.431,00	
TRITÓN100-15	7,5	10	100	-	15,7	33,5	33	31,2	30,4	30	28,1	27	25,8	24,8	23	19	15,5	11,2			-	1.259,00			

ELECTROBOMBA SUMERGIBLE SERIE DM

DESCRIPCIÓN

- Electrobombas de aguas residuales con **rodete centrífugo de tipo monocanal**. Garantiza, además de un caudal elevado, una altura óptima.
- Apropriadas para aplicaciones civiles e industriales.
- Disponibles para aplicaciones móviles y de modo fijo con pie de acoplamiento.
- Motor a **2.900 rpm**.

MATERIALES

- Cuerpo de bomba, camisa estátor: **Fundición**
- Eje: **Acero INOX 304**
- Impulsor: **Fundición**
- Doble cierre mecánico: **Carb/Sic - Sic/Sic**
- Junta tórica: **NBR**
- Cable: **10 m**

ÁREA DE TRABAJO

- Temperatura máx. del líquido: **40°C**
- Profundidad máx. de inmersión: **10 m**
- Grado de protección: **IP68**
- Aislamiento clase: **F**



ZÓCALO DISPONIBLE



RODETE

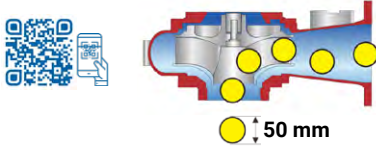

50 mm

		CAUDAL											
		0	12	24	36	48	60	72	84	108	132	144	
m ³ /h		0	12	24	36	48	60	72	84	108	132	144	
l/min		0	200	400	600	800	1000	1200	1400	1800	2200	2400	

MODELO	P ₂		P ₁	DN	SÓLID.	ACOPLE	I (A)	PESO	CAUDAL											P.V.P.
	kW	Hp							W	mm	mm	Ø mm	3~400V	Kg	ALTURA DE CARGA EN METROS					
DM 1000	7,5	10	9.600	80	50	80	16,3	94,0	34,9	30,9	28,3	26,1	23,7	21,3	18,7	16,1	10,2	4,6	2,1	2.832,00

ELECTROBOMBA SUMERGIBLE SERIE DM4

DESCRIPCIÓN

- Electrobombas de aguas residuales con **rodete centrífugo de tipo monocanal**. Garantiza, además de un caudal elevado, una altura óptima.
- Apropriadas para aplicaciones civiles e industriales.
- Disponibles para aplicaciones móviles y de modo fijo con pie de acoplamiento.
- Motor a **1.500 rpm**.

MATERIALES

- Cuerpo de bomba, camisa estátor: **Fundición**
- Eje: **Acero INOX 304**
- Impulsor: **Fundición**
- Doble cierre mecánico: **Carb/Sic - Sic/Sic**
- Junta tórica: **NBR**
- Cable: **10 m**

ÁREA DE TRABAJO

- Temperatura máx. del líquido: **40°C**
- Profundidad máx. de inmersión: **10 m**
- Grado de protección: **IP68**
- Aislamiento clase: **F**



ZÓCALO DISPONIBLE



RODETE

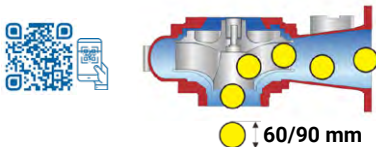

60/90 mm

		CAUDAL											
		0	12	24	36	48	72	84	96	120	156	180	
m ³ /h		0	12	24	36	48	72	84	96	120	156	180	
l/min		0	200	400	600	800	1200	1400	1600	2000	2600	3000	

MODELO	P ₂		P ₁	DN	SÓLID.	ACOPLE	I (A)	PESO	CAUDAL											P.V.P.
	kW	Hp							W	mm	mm	Ø mm	3~400V	Kg	ALTURA DE CARGA EN METROS					
DM 4-400	3,0	4,0	3.200	100	60	100	6,5	77,0	14	12,7	11,6	10,4	9,2	6,7	5,4	4	2.470,00			
DM 4-550	4,0	5,5	5.200	100	90	100	9,4	105,0	14,7	14	13,2	12,5	11,7	10,1	9,2	8,3	6,5	3,6	1,3	3.089,00
DM 4-750	5,5	7,5	6.100	100	90	100	11,8	108,0	17	16,2	15,4	14,7	13,8	12,2	11,4	10,4	8,4	5,1	2,6	3.133,00

ELECTROBOMBAS SUMERGIBLES SERIE DV

DESCRIPCIÓN

- Electrobombas de aguas residuales para líquidos cargados con **turbina de tipo vórtex** para aplicaciones civiles e industriales.
- Disponibles para aplicaciones móviles y fija con pie de acoplamiento.
- Motor a **2.900 rpm**.

MATERIALES

- Cuerpo de bomba, camisa estátor: **Fundición**
- Eje: **Acero INOX 304**
- Impulsor: **Fundición**
- Doble cierre mecánico: **Cer/Graf - Sic/Sic**
- Cable: **10 m**

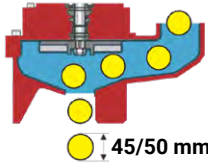

ÁREA DE TRABAJO

- Temperatura máx. del líquido: **40°C**
- Profundidad máx. de inmersión: **20 m**
- Grado de protección: **IP68**
- Aislamiento clase: **F**



ZÓCALO DISPONIBLE



IMPULSOR

MODELO	P ₂ kW	P ₁ Hp	DN W	SÓLIDOS mm	ACOPLE mm	I (A) 3~400V	PESO Kg	CAUDAL										P.V.P. C																																																			
								m ³ /h	0	12	24	36	48	60	72	90	108		120	l/min	0	200	400	600	800	1000	1200	1500	1800	2000																																							
DV 550	4,0	5,5	4.900	80	45	80	10,4	72,0	<table border="1"> <thead> <tr> <th colspan="10">ALTURA DE CARGA EN METROS</th> <th>TRIF.</th> </tr> </thead> <tbody> <tr> <td>23,9</td> <td>22,2</td> <td>19,3</td> <td>16,3</td> <td>13,2</td> <td>10</td> <td>7,1</td> <td>2,6</td> <td colspan="3"></td> <td>2.041,00</td> </tr> <tr> <td>24,2</td> <td>22,7</td> <td>20,7</td> <td>18,7</td> <td>16,4</td> <td>13,9</td> <td>11,1</td> <td>6,6</td> <td>2,8</td> <td colspan="3"></td> <td>2.867,00</td> </tr> <tr> <td>26,7</td> <td>25,2</td> <td>23,2</td> <td>21,2</td> <td>18,8</td> <td>16,3</td> <td>13,7</td> <td>9,4</td> <td>5,1</td> <td>2,6</td> <td colspan="3"></td> <td>2.910,00</td> </tr> </tbody> </table>										ALTURA DE CARGA EN METROS										TRIF.	23,9	22,2	19,3	16,3	13,2	10	7,1	2,6				2.041,00	24,2	22,7	20,7	18,7	16,4	13,9	11,1	6,6	2,8				2.867,00	26,7	25,2	23,2	21,2	18,8	16,3	13,7	9,4	5,1	2,6				2.910,00	
ALTURA DE CARGA EN METROS										TRIF.																																																											
23,9	22,2	19,3	16,3	13,2	10	7,1	2,6				2.041,00																																																										
24,2	22,7	20,7	18,7	16,4	13,9	11,1	6,6	2,8				2.867,00																																																									
26,7	25,2	23,2	21,2	18,8	16,3	13,7	9,4	5,1	2,6				2.910,00																																																								
DV 750	5,5	7,5	8.500	80	50	80	14,4	91,0																																																													
DV 1000	7,5	10	9.600	80	50	80	16,4	93,0																																																													

ELECTROBOMBA SUMERGIBLE SERIE DV4

DESCRIPCIÓN

- Electrobombas de aguas residuales con **turbina de tipo vórtex** para aplicaciones civiles e industriales.
- Disponibles para aplicaciones móviles y fija con pie de acoplamiento.
- Motor a **1.500 rpm**.

MATERIALES

- Cuerpo de bomba, camisa estátor: **Fundición**
- Eje: **Acero INOX 304**
- Impulsor: **Fundición**
- Doble cierre mecánico: **Cer/Graf - Sic/Sic**
- Cable: **10 m**

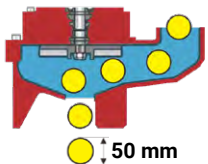

ÁREA DE TRABAJO

- Temperatura máx. del líquido: **40°C**
- Profundidad máx. de inmersión: **20 m**
- Grado de protección: **IP68**
- Aislamiento clase: **F**



ZÓCALO DISPONIBLE



IMPULSOR

MODELO	P ₂ kW	P ₁ Hp	DN W	SÓLIDOS mm	ACOPLE mm	I (A) 3~400V	PESO Kg	CAUDAL										P.V.P. C																																																			
								m ³ /h	0	24	48	72	96	120	144	168	180		204	l/min	0	400	800	1200	1600	2000	2400	2800	3000	3400																																							
DV 4-400	3,0	4,0	4.900	100	50	100	8,7	76,0	<table border="1"> <thead> <tr> <th colspan="10">ALTURA DE CARGA EN METROS</th> <th>TRIF.</th> </tr> </thead> <tbody> <tr> <td>11,8</td> <td>10,7</td> <td>9,2</td> <td>7,3</td> <td>5</td> <td>2,3</td> <td colspan="5"></td> <td>2.401,00</td> </tr> <tr> <td>12,6</td> <td>12,2</td> <td>11,4</td> <td>10,3</td> <td>9,1</td> <td>7,6</td> <td>5,7</td> <td>3,7</td> <td>2,6</td> <td colspan="3"></td> <td>3.135,00</td> </tr> <tr> <td>14,7</td> <td>14,2</td> <td>13,3</td> <td>12,4</td> <td>11,2</td> <td>9,6</td> <td>7,9</td> <td>5,9</td> <td>4,8</td> <td>2,6</td> <td colspan="3"></td> <td>3.169,00</td> </tr> </tbody> </table>										ALTURA DE CARGA EN METROS										TRIF.	11,8	10,7	9,2	7,3	5	2,3						2.401,00	12,6	12,2	11,4	10,3	9,1	7,6	5,7	3,7	2,6				3.135,00	14,7	14,2	13,3	12,4	11,2	9,6	7,9	5,9	4,8	2,6				3.169,00	
ALTURA DE CARGA EN METROS										TRIF.																																																											
11,8	10,7	9,2	7,3	5	2,3						2.401,00																																																										
12,6	12,2	11,4	10,3	9,1	7,6	5,7	3,7	2,6				3.135,00																																																									
14,7	14,2	13,3	12,4	11,2	9,6	7,9	5,9	4,8	2,6				3.169,00																																																								
DV 4-550	4,0	5,5	7.500	100	50	100	12,9	104,0																																																													
DV 4-750	5,5	7,5	9.000	100	50	100	15,4	109,0																																																													

CUADROS MULTIFUNCIÓN SERIE ALL-IN-ONE

DESCRIPCIÓN

- Cuadros eléctricos de control multifunción diseñados para gestionar el funcionamiento de una o dos bombas en aplicaciones como grupos de presión, estaciones de aguas residuales y control de pozos o depósitos.
- Permite comandar **bombas hasta 13 A**.
- Grado de protección: **IP54**
- Un único cuadro hace las funciones de **cuadro de protección y alternancia, cuadro de pozo con sondas y cuadro de aguas residuales o pluviales**.



El mismo cuadro permite operar con tensión monofásica o trifásica según las siguientes configuraciones:



- ✓ **Config. monofásica:** Admite una tensión de entrada monofásica (1~220) y está diseñado para la operación de electrobombas monofásicas con una potencia máxima de 2,0 Hp
- ✓ **Config. trifásica:** Admite una tensión de entrada trifásica (3~380) y está diseñado para la operación de electrobombas trifásicas con una potencia máxima de 5,5 Hp.

MODELO	Nº BOMBAS	CONFIG. MONOFÁSICA				CONFIG. TRIFÁSICA				P.V.P.
		INT. MÁX. A	T. ENTRADA V	T. BOMBA V	P. MÁX. Hp	T. ENTRADA V	T. BOMBA V	P. MÁX. Hp		
ALLINONE-1B	1	13	220/230	220/230	2,0	380/400	380/400	5,5	275,00	
ALLINONE-2B	2	13	220/230	220/230	2,0	380/400	380/400	5,5	407,00	

ESQUEMAS DE INSTALACIÓN

GRUPO DE PRESIÓN
CON INTERRUPTOR DE NIVEL

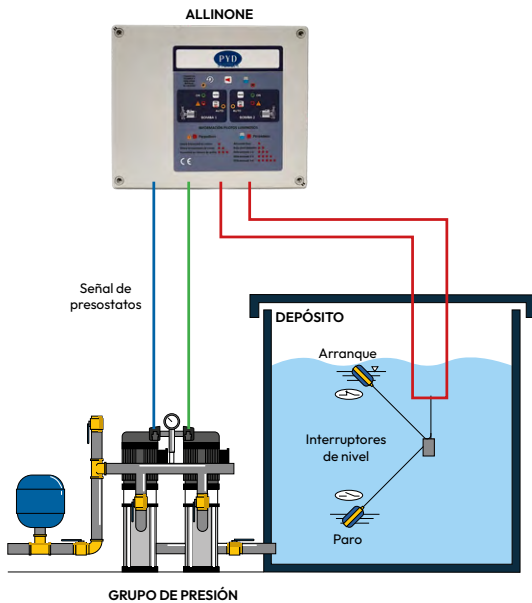

ELECTROBOMBAS DE AGUAS
RESIDUALES CON BOYAS

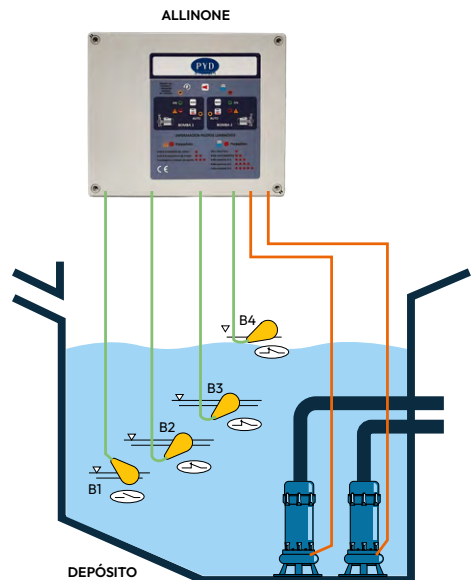

- B1: Boya de desconexión
- B2: Boya de arranque primer nivel
- B3: Boya de arranque segundo nivel
- B4: Boya de alarma arranque de emergencia

DESCRIPCIÓN

- Cuadros para una o dos bombas con alternancia.
- Caja de material plástico con protección **IP55**.
- Protección por disyuntores térmicos.
- Con **alarma óptica y acústica** de sobrenivel.



MODELO	TENSIÓN	CONEXIÓN	POTENCIA	INT (A)		P.V.P.	
	V	Tipo	Hp	MÍN	MÁX	UNA BOMBA	DOS BOMBAS
FX-D0,5M	1~230	Directo	0,5	2,8	4,0	209,00	405,00
FX-D1M	1~230	Directo	1,0	4,5	6,3	209,00	405,00
FX-D1,5M	1~230	Directo	1,5	7,0	10,0	209,00	405,00
FX-D2M	1~230	Directo	2,0	9,0	12,0	209,00	405,00
FX-D1T4	3~400	Directo	1,0	1,8	2,5	209,00	405,00
FX-D1,5T4	3~400	Directo	1,5	2,2	3,2	209,00	405,00
FX-D2T4	3~400	Directo	2,0	3,5	5,0	209,00	405,00
FX-D3T4	3~400	Directo	3,0	4,5	6,3	209,00	405,00
FX-D4T4	3~400	Directo	4,0	5,5	8,0	209,00	405,00
FX-D5,5T4	3~400	Directo	5,5	7,0	10,0	209,00	405,00
FX-D7,5T4	3~400	Directo / Y-Δ	7,5	9,0	12,0	321,00	547,00
FX-ET10T4	3~400	Y-Δ	10,0	14,0	20,0	880,00	1.637,00
FX-ET15T4	3~400	Y-Δ	15,0	20,0	25,0	1.002,00	1.840,00

ZÓCALO/PIE DE ACOPLAMIENTO

DESCRIPCIÓN

- Sistema de acoplamiento en hierro fundido para montaje y/o sujeción de nuestras bombas residuales.

PARA BOMBAS SERIE WQ Y U



MODELO	DN Ø	P.V.P.
T065-65	65/G2½"	256,00
T080-80	80/G3"	363,00
T0100-100	100/G4"	512,00

No se incluye: Pernos de la base, tubo guía y pernos de soporte de la guía superior

PARA BOMBAS SERIE DM, DM4, DV, DV4



MODELO	DN Ø	P.V.P.
ZOCP80	80/G3"	715,00
ZOCP100	100/G4"	889,00

No se incluye: Pernos de la base, tubo guía y pernos de soporte de la guía superior

PARA BOMBAS SERIE SEMISON

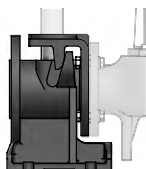

MODELO	DN Ø	P.V.P.
ZOCB50	50/G2"	341,00
ZOCB65	65/G2½"	310,20

No se incluye: Pernos de la base, tubo guía y pernos de soporte de la guía superior

PARA BOMBAS SERIE TIGER-MAX



MODELO	DN Ø	P.V.P.
ZOCT50	50/2"	187,00
CODT50	50/2"	32,00

No se incluye: Pernos de la base, tubo guía y pernos de soporte de la guía superior

ESTACIÓN DE AGUAS RESIDUALES SERIE AQUATANK



DESCRIPCIÓN

- Depósitos para elevación por bombeo de aguas residuales.
- Compuestos por nuestras electrobombas Serie **TIGER INOX**, con interruptor de nivel y cesto de cribado en la entrada para la retención de sólidos gruesos.
- El depósito arranca y se detiene gracias al interruptor de nivel de la bomba.



MATERIALES

ELECTROBOMBA

- Cuerpo de bomba: **Acero INOX 304**
- Soporte del motor: **Acero INOX 304**
- Eje: **Acero INOX 304**
- Impulsor: **Acero INOX 304**
- Doble cierre mecánico: **Carb/Sic - Carb/Sic**
- Cable: **10 m**

ÁREA DE TRABAJO

- Condensador interno
- Temperatura máx. del líquido: **40°C**
- Profundidad máx. de inmersión: **5 m**
- Grado de protección: **IP68**
- Disponible en 2 capacidades
- Servicio continuo
- Comando con boyas externas (bajo demanda)



INTERRUPTOR DE NIVEL



CESTO DE CRIBADO

DEPÓSITO

- Cuerpo: **Polietileno**
- Cesto: **Polietileno**



MODELO	BOMBA							DEPÓSITO		CAUDAL					P.V.P C															
	P ₂		SALIDA Ø"	SÓLIDOS mm	I (A) 1~230V	COND. µF	CAP. L	DN ENT. mm	m ³ /h																					
	kW	Hp							0	6	12	18	24																	
AQUATANK 100	1,1	1,5	1½	38	6,8	30	100	125	0	100	200	300	400																	
AQUATANK 200	1,1	1,5	1½	38	6,8	30	200	125	<table border="1"> <thead> <tr> <th colspan="5">ALTURA DE CARGA EN METROS</th> <th rowspan="2">MONOF.</th> </tr> <tr> <th>12,5</th> <th>10,6</th> <th>8</th> <th>5,5</th> <th>2</th> </tr> </thead> <tbody> <tr> <td>1.100,00</td> <td>1.200,00</td> <td></td> <td></td> <td></td> <td></td> </tr> </tbody> </table>					ALTURA DE CARGA EN METROS					MONOF.	12,5	10,6	8	5,5	2	1.100,00	1.200,00				
ALTURA DE CARGA EN METROS					MONOF.																									
12,5	10,6	8	5,5	2																										
1.100,00	1.200,00																													

INCLUYE:

1. Bomba de achique Serie TIGER INOX
2. Interruptor de nivel
3. Cesto para grandes sólidos
4. Tapa de acceso para extracción

DIMENSIONES (cm)

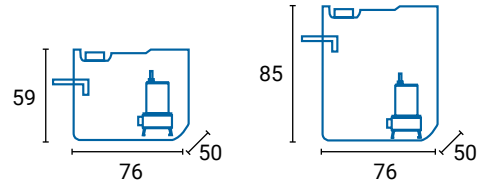

AQUATANK 200



AQUATANK 100

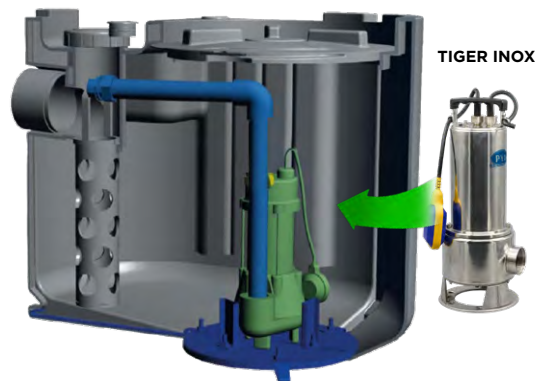

ESTACIÓN DE AGUAS RESIDUALES SERIE TANKPLUS



DESCRIPCIÓN

- Depósito vertical con diseño cilíndrico de gran capacidad para elevación por bombeo de aguas residuales.
- Compuesto por dos electrobombas trifásicas de la **Serie TIGER INOX** y tres interruptores de nivel marca **TAURUS**.



MATERIALES

ELECTROBOMBAS

- Cuerpo de bomba: **Acero INOX 304**
- Soporte del motor: **Acero INOX 304**
- Eje: **Acero INOX 304**
- Impulsor: **Acero INOX 304**
- Doble cierre mecánico: **Carb/Sic - Carb/Sic**
- Cable: **10 m**

ÁREA DE TRABAJO

- Temperatura máx. del líquido: **40°C**
- Profundidad máx. de inmersión: **5 m**
- Grado de protección: **IP68**
- Servicio continuo



DOBLE BOMBA INOX



BOYAS DE NIVEL TAURUS

DEPÓSITO

- Cuerpo: **Polietileno**

MODELO	2 X BOMBAS						DEPÓSITO		CAUDAL						P.V.P ^C	
	P ₂		SALIDA SÓLIDOS		I (A)	CAP.	DN ENT.	m ³ /h	0	12	24	36	48	60		TRIF.
	kW	Hp	Ø"	mm	3~400V	L	mm	l/min	0	200	400	600	800	1000		
TANKPLUS 400	1,5	2,0	2	50	3,2	400	125	ALTURA DE CARGA EN METROS						2.700,00		
								14	12,5	11	9	7	4			

DIMENSIONES (cm)

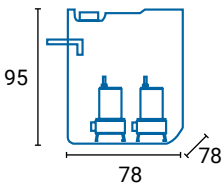

ESQUEMA DE INSTALACIÓN

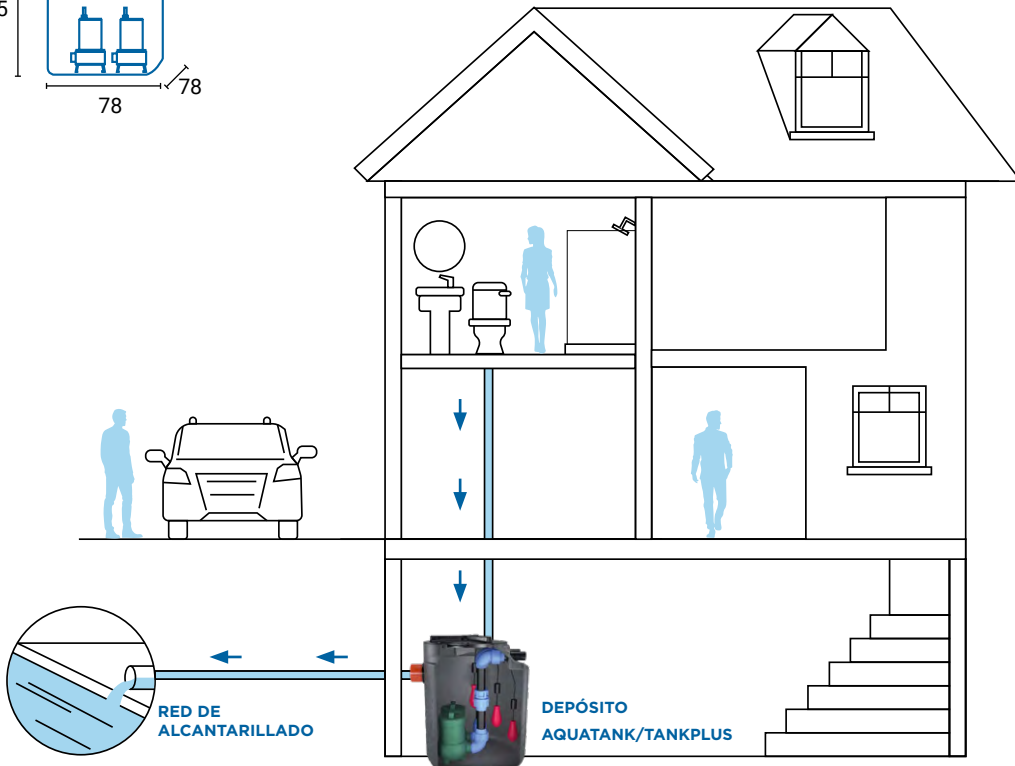

ELECTROBOMBAS DE ACHIQUE SERIE KS

DESCRIPCIÓN

- Electrobomba de achique con carcasa de **acero inoxidable y fundición de hierro** para dotarla de **gran durabilidad**.
- Alta profundidad de inmersión gracias a su cierre mecánico resistente a altas presiones.
- **Impulsor semiabierto** de aleación de alto contenido en cromo y recubrimiento antiabrasión para alargar la vida útil.



MATERIALES

- Cuerpo de bomba y de motor: **Acero INOX**
- Rejilla: **Acero INOX**
- Cuerpo de expulsión: **Fundición**
- Impulsor: **Aleación de cromo con recubrimiento antiabrasión en hierro dúctil**
- Cierre mecánico: **Cer-Sic/Carb-Cer**

ÁREA DE TRABAJO

- Temperatura máx. del líquido: **40°C**
- Profundidad máx. de inmersión: **25 m**
- Grado de protección: **IP68**
- Aislamiento clase: **F**



m ³ /h	CAUDAL									
	0	10	15	27	35	40	55	70	90	105
l/min	0	160	250	450	583	667	917	1167	1500	1750

MODELO	P ₂		DN	SÓLIDOS	I (A)	PESO	CAUDAL										P.V.P												
	kW	Hp					mm	mm	1~230V	3~400V	Kg	ALTURA DE CARGA EN METROS										MONOF.	TRIF.						
KSM21.5	1,5	2,0	50	8,5	10,0	-	37,0	21	17	15	7											955,30	-						
KS31.5	1,5	2,0	80	8,5	10,0	3,5	37,0	14	13	11,5	8,5	5	2											1.005,00	972,10				
KS22.2	2,2	3,0	50	8,5	-	5,0	40,0	25	22	20	12											-	1.034,30						
KS32.2	2,2	3,0	80	8,5	-	5,0	40,0	18,5	17	16	13,5	11	9,5	3,5											-	1.060,70			
KS23.7	3,7	5,0	50	8,5	-	7,7	58,0	32	30	28	21	9											-	1.613,70					
KS33.7	3,7	5,0	80	8,5	-	7,7	58,0	29	26	24	21	18	16	7											-	1.628,10			
KS43.7	3,7	5,0	100	8,5	-	7,7	59,0	18	18	18	17	16	15	12	9	4											-	1.647,20	
KS35.5	5,5	7,5	80	8,5	-	11,4	66,0	35	30	28	25	23	22	16	6											-	1.992,00		
KS45.5	5,5	7,5	100	8,5	-	11,4	67,0	26	23,5	23	22	20	19	18	15	9	3											-	2.011,20

KS...F: Modelo con interruptor de nivel

ESQUEMA DE INSTALACIÓN PARA BOMBEO DE AGUAS RESIDUALES

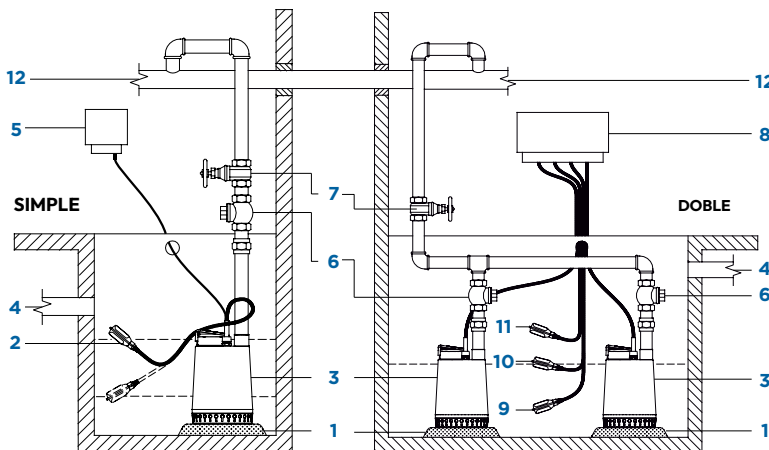

1. Soporte de bomba
2. Boya de nivel/máx
3. Bomba Dumper
4. Admisión de agua
5. Cuadro protección simple
6. Válvula de bola desplazada
7. Válvula de mariposa
8. Cuadro protección man. alterna
9. Boya nivel mínimo
10. Boya nivel de trabajo
11. Boya nivel máximo
12. Línea de evacuación

ELECTROBOMBA DE ACHIQUE SERIE KBZ

DESCRIPCIÓN

- Electrobombas de achique con **carcasa rígida de hierro fundido** para dotarlas de gran durabilidad.
- Alta profundidad de inmersión gracias a su cierre mecánico resistente a altas presiones.
- Impulsor semabierto de aleación de alto contenido en cromo con recubrimiento antiabrasión para alargar la vida útil.
- Los modelos por debajo de 15,0 kW cuentan con protección térmica.



MATERIALES

- Cuerpo de bomba y de motor: **Fundición**
- Rejilla: **Fundición**
- Impulsor: **Aleación de cromo y hierro fundido dúctil (recubrimiento antiabrasión)**
- Cierre mecánico:
(≤2,2Kw) **Sic-Sic/Carb-Sic**
(≥3,7Kw) **Sic-Sci/Sic-Sic**

ÁREA DE TRABAJO

- Temperatura máx. del líquido: **40°C**
- Profundidad máx. de inmersión: **25 m**
- Grado de protección: **IP68**
- Aislamiento clase: **F**



ALTAS TEMPERATURAS
DISPONIBLE BAJO DEMANDA



		CAUDAL											
m³/h		0	20	40	50	60	70	80	90	105	120	147	156
l/min		0	333	667	833	1000	1167	1333	1500	1750	2000	2450	2600

MODELO	P ₂		DN	SÓLIDOS	I (A)	PESO
	kW	Hp				
KBZ21.5	1,5	2,0	50	8,5	3,5	40,0
KBZ31.5	1,5	2,0	80	8,5	3,5	40,0
KBZ22.2	2,2	3,0	50	8,5	5,0	43,0
KBZ32.2	2,2	3,0	80	8,5	5,0	43,0
KBZ23.7	3,7	5,0	50	8,5	7,7	68,0
KBZ33.7	3,7	5,0	80	8,5	7,7	68,0
KBZ43.7	3,7	5,0	100	8,5	7,7	68,0
KBZ35.5	5,5	7,5	80	8,5	11,4	84,0
KBZ45.5	5,5	7,5	100	8,5	11,4	84,0
KBZ47.5	7,5	10	100	11,5	15,0	116,0
KBZ67.5	7,5	10	150	19,5	15,0	119,0
KBZ411	11	15	100	11,5	22,0	148,0
KBZ611	11	15	150	19,5	22,0	150,0
KBZ415	15	20	100	11,5	29,5	158,0
KBZ615	15	20	150	19,5	29,5	160,0

		CAUDAL												P.V.P. C
		ALTURA DE CARGA EN METROS												TRIF.
22	12												976,00	
14	11	2										997,00		
26	19												1.095,00	
20	16	10	6									1.131,00		
34	26												1.694,00	
29	23	15	9								1.746,00			
19	17	16	14	11	9	7	4					1.787,00		
34	30	24	21	16	10							2.211,00		
23	22	18	16	15	13	10	8	2				2.263,00		
40	37	34	31	27	21	12						2.929,00		
32	28	25	24	22	20	18	15	12	5				3.187,00	
49	46	42	39	34	27	15							3.921,00	
32	31	30	29	27	26,5	25	24	21	17	6			4.040,00	
58	54	51	46	42	34	21							4.722,00	
40	38	36	34	33	32	31	30	28	23	13	3		4.758,00	



VISITE NUESTRA WEB
PARA OBTENER MÁS
INFORMACIÓN TÉCNICA
DE NUESTROS PRODUCTOS



Capture el código QR para acceder a nuestra web.

ELECTROBOMBA DE ACHIQUE SERIE NTZ

DESCRIPCIÓN

- Electrobomba de achique sumergible con motor de 4 polos (1.400 rpm) para una mayor vida útil. Útil para ingeniería civil, minas, canteras, etc.
- Refrigeración por agua para permitir que la bomba funcione a niveles bajos de agua durante un periodo prolongado de tiempo sin riesgo de sobrecalentamiento.
- **Impulsor de aleación de alto contenido en cromo** combinado con agitador para bombear lodos pesados.

MATERIALES

- Cuerpo de bomba: **Fundición**
- Cuerpo del motor: **Fundición**
- Rejilla: **Acero**
- Impulsor: **Aleación de cromo**
- Cierre mecánico: **Sic-Sic/Sic-Sic**
- Cable: **8 m**

ÁREA DE TRABAJO

- Temperatura máx. del líquido: **40°C**
- Profundidad máx. de inmersión: **20 m**
- Grado de protección: **IP68**
- Aislamiento clase: **F**



IMPULSOR



AGITADOR



		CAUDAL							
m ³ /h		0	15	30	45	60	75	90	105
l/min		0	250	500	750	1000	1250	1500	1750

MODELO	P ₂		DN	SÓLIDOS		I (A)	PESO	CAUDAL								P.V.P. C			
	kW	Hp		mm	mm			3~400V	Kg	ALTURA DE CARGA EN METROS								TRIF.	
NTZ-32.2	2,2	3,0	80	20	5,5	99,0	12	11,5	10,5	9,5	8								2.257,00
NTZ-33.7	3,7	5,0	80	20	8,1	116,0	15	14,5	13,8	12,6	11,2	9,3	7						2.752,00
NTZ-43.7	3,7	5,0	100	20	8,1	116,0	15	14,5	13,8	12,6	11,2	9,3	7	4,5					2.760,00

ELECTROBOMBA DE ACHIQUE SERIE KBS

DESCRIPCIÓN

- Electrobomba sumergible con **motor de 4 polos** (1.400 rpm) para una mayor vida útil.
- Útil para ingeniería civil, minas, canteras, lodos, plantas de tratamientos de agua residuales.
- **Impulsor de aleación de alto contenido en cromo** combinado con agitador para bombear lodos pesados.

MATERIALES

- Cuerpo de bomba: **Fundición**
- Cuerpo del motor: **Fundición**
- Rejilla: **Acero**
- Impulsor: **Aleación de cromo**
- Cierre mecánico: **Tc-Sic/Sic-Sic (≥15Kw) y en Sic-Sic/Sic-Sic**
- Cable: **8 m**

ÁREA DE TRABAJO

- Temperatura máx. del líquido: **40°C**
- Profundidad máx. de inmersión: **15 m**
- Grado de protección: **IP68**
- Aislamiento clase: **F**



IMPULSOR



AGITADOR



		CAUDAL											
m ³ /h		0	20	40	50	80	120	160	200	240	280	320	360
l/min		0	333	666	833	1333	2000	2666	3333	4000	4666	5333	6000

MODELO	P ₂		DN	SÓLIDOS		I (A)	PESO	CAUDAL												P.V.P. C
	kW	Hp		mm	mm			3~400V	Kg	ALTURA DE CARGA EN METROS										
80KBS44	4,0	5,5	80	30	10,2	119,0	14,8	13,5	12	11	7								3.240,00	
100KBS46	6,0	8,0	100	30	13,8	151,0	17	16,5	15	14	11	6							3.980,00	
150KBS49	9,0	12	150	30	19,5	183,0	21,5	20	19,5	18	17	13							4.530,00	
200KBS415	15	20	200	30	30,1	278,0	22	22	21,5	21	21	19	17,5	16	14	11,5	8	3	8.545,00	
200KBS422	22	30	200	30	42,0	434,0	32	31	31	30	30	28,5	26,5	24	20,5	16,5	13	3	10.669,00	

ELECTROBOMBA DE ACHIQUE SERIE CANTER

DESCRIPCIÓN

- El cuerpo del motor y la bomba están fabricados en fundición dándole una mayor durabilidad.
- **Gran profundidad de inmersión** máxima aumentada gracias al **doble cierre mecánico** resistente a alta presión.
- La electrobomba puede ser parcialmente sumergida, ya que el flujo del agua bombeada actúa como sistema de refrigeración para el motor.
- Aplicable en drenaje de pozos profundos o deshidratación de cabezales altos, obras de ingeniería civil y construcción, minas, canteras y lodos, plantas de tratamiento de aguas residuales y bombeo general.

MATERIALES

- Cuerpo de bomba: **Fundición**
- Cuerpo del motor: **Fundición**
- Rejilla: **Acero INOX 304**
- Eje: **Acero INOX 304**
- Impulsor: **Acero INOX 304**
- Doble cierre mecánico: **Carb/Sic - Sic/Sic**
- Junta tórica: **buna-N**
- Cable: **20 m**

ÁREA DE TRABAJO

- Temperatura máx. del líquido: **40°C**
- Profundidad máx. de inmersión: **30 m**
- Grado de protección: **IP68**
- Aislamiento clase: **F**



MODELO	P ₂		DN	SÓLIDOS	I (A)	PESO
	kW	Hp				
CANTER 422	22	30	100	6	41,5	410,0
CANTER 430	30	40	100	6	54,0	415,0
CANTER 622	22	30	150	15	41,5	425,0
CANTER 630	30	40	150	15	54,0	430,0
CANTER 637	37	50	150	6	66,0	615,0
CANTER 645	45	60	150	6	80,0	620,0
CANTER 655	55	75	150	8	100,0	880,0
CANTER 675	75	100	150	8	134,0	880,0
CANTER 690	90	120	150	10	162,0	1110,0

m ³ /h	CAUDAL										P.V.P. C	
	0	25	50	75	100	125	150	175	200	220		
l/min	0	416	833	1250	1666	2083	2500	2916	3333	3666		
	ALTURA DE CARGA EN METROS										TRIF.	
	68	67	64	54	49	23						
											13.267,00	
	78	76	74	69	64	55	40	10				15.291,00
	50	48	46	44	41	36	31	10				13.267,00
	58	57	56	54	51	47	43	37	27	10	15.291,00	
	83	82	80	76	72	64	55	42	27	10	19.846,00	
	90	89	87	83	78	71	62	51	35	10	22.780,00	
	105	103	100	96	91	86	78	45				37.961,00
	131	130	127	123	118	111	100	60				42.519,00
	140	139	138	137	134	129	118	80				53.409,00

(*). Disponible bajo demanda. Consulte plazo de entrega con nuestro dpto. comercial.

MODELO	P ₂		DN	SÓLIDOS	I (A)	PESO
	kW	Hp				
CANTER 837	37	50	200	20	66,0	625,0
CANTER 845	45	60	200	20	80,0	630,0
CANTER 855	55	75	200	20	100,0	930,0
CANTER 875	75	100	200	20	134,0	930,0
CANTER 890	90	120	200	20	162,0	1120,0
CANTER 8110	110	150	200	20	198,0	1150,0

m ³ /h	CAUDAL									P.V.P. C	
	0	50	100	150	200	250	300	350	370		
l/min	0	833	1666	2500	3333	4166	5000	5833	6166		
	ALTURA DE CARGA EN METROS									TRIF.	
	48	46	44	41	37	32	25				
										19.846,00	
	53	50	48	45	42	38	32	20	10	22.780,00	
	65	63	61	58	55	50	36				37.961,00
	70	69	68	67	65	62	57	48	39	42.519,00	
	90	88	86	83	79	73	64	48			53.409,00
	106	105	104	103	99	93	83	65	55	58.463,00	

(*). Disponible bajo demanda. Consulte plazo de entrega con nuestro dpto. comercial.

ELECTROBOMBA DE ACHIQUE SERIE CANTER/A

DESCRIPCIÓN

- El cuerpo del motor y la bomba están fabricados en fundición dándole una mayor durabilidad.
- **Gran profundidad de inmersión** máxima aumentada gracias al **doble cierre mecánico** resistente a alta presión.
- La electrobomba puede ser parcialmente sumergida, ya que el flujo del agua bombeada actúa como sistema de refrigeración para el motor.
- Aplicable en drenaje de pozos profundos o deshidratación de cabezales altos, obras de ingeniería civil y construcción, minas, canteras y lodos, plantas de tratamiento de aguas residuales y bombeo general.

MATERIALES

- Cuerpo de bomba: **Fundición**
- Cuerpo del motor: **Fundición**
- Rejilla: **Acero INOX 304**
- Eje: **Acero INOX 304**
- Impulsor: **Acero INOX 304**
- Doble cierre mecánico: **Carb/Sic - Sic/Sic**
- Cable: **20 m**

ÁREA DE TRABAJO

- Temperatura máx. del líquido: **40°C**
- Profundidad máx. de inmersión: **30 m**
- Grado de protección: **IP68**
- Aislamiento clase: **F**

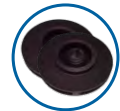

DOBLE IMPULSOR



MODELO	P ₂		DN	ARRANQUE	SÓLIDOS	I (A)	PESO	CAUDAL										P.V.P. C								
	kW	Hp						mm	Tipo	mm	3~400V	Kg	m ³ /h	0	5	10	20		30	40	60	80	100	l/min	0	83
CANTER/A 230	3,0	4,0	50	Directo	6	6,2	52	ALTIMETRO										4.394,00								
CANTER/A 255	5,5	7,5	50	Directo	6	11,4	100	ALTIMETRO										5.807,00								
CANTER/A 311	11	15	80	Directo	8,5	22,0	160	ALTIMETRO										7.665,00								
CANTER/A 322	22	30	80	Y-Δ	8,5	41,5	278	ALTIMETRO										13.450,00								
CANTER/A 437	37	50	100	Y-Δ	6	66,0	500	ALTIMETRO										20.329,00								

(*) Disponible bajo demanda. Consulte plazo de entrega con nuestro dpto. comercial.
Y-Δ: Arranque en Estrella-Triángulo

MODELO	P ₂		DN	ARRANQUE	SÓLIDOS	I (A)	PESO	CAUDAL												P.V.P. C								
	kW	Hp						mm	Tipo	mm	3~400V	Kg	m ³ /h	0	25	50	75	100	125		150	175	200	210	l/min	0	416	833
CANTER/A 475	75	100	100	Y-Δ	15	134,0	1000	ALTIMETRO												44.693,00								
CANTER/A 490	90	120	100	Y-Δ	15	162,0	1055	ALTIMETRO												49.091,00								
CANTER/A 6110	110	150	100	Y-Δ	8	198,0	1245	ALTIMETRO												60.082,00								
CANTER/A 6150	150	200	100	Y-Δ	12	260,0	1428	ALTIMETRO												68.310,00								

(*) Disponible bajo demanda. Consulte plazo de entrega con nuestro dpto. comercial.
AET: Arranque en Estrella-Triángulo



MOTOBOMBAS GASOLINA



PYD
ELECTROBOMBAS

MOTOBOMBA CENTRÍFUGA AUTOASPIRANTE SERIE ENG

DESCRIPCIÓN

- Motobombas de combustible de bajo consumo, útil para abastecimientos de agua y drenaje para fábricas, minas, así como para riego de campos, etc.
- Nuevo diseño único con función ergonómica.
- Bastidor de bomba portátil y compacto.
- Impulsor diseñado con sistema hidráulico de alta eficiencia.

MATERIALES

- Llave de la bomba: **Aluminio**
- Tubo: **Aluminio**



ÁREA DE TRABAJO

- Temperatura máx. del líquido: **40°C**
- Nivel de ruido: **106dB(A)**
- Combustible: **Gasolina**
- Depósito: **1,8L**



MODELO	DN Ø"		P ₂		ALTURA MÁX. m	CAUDAL MÁX. m ³ /h	ALT. ASP. m	MOTOR		PESO Kg	P.V.P.	B
	IMP.	ASP.	kW	Hp				Cilindrada	Tiempos			
ENG-25	1	1	1,8	2,4	30	7	7	80 cc	4	15,1	239,00	
ENG-40	1 1/2	1 1/2	1,8	2,4	22	17	7	80 cc	4	15,6	269,00	

MOTOBOMBA CENTRÍFUGA AUTOASPIRANTE SERIE ENG

DESCRIPCIÓN

- Motobomba de combustible de bajo consumo, útil para abastecimientos de agua y drenaje para fábricas, minas, así como para riego de campos, etc.
- Nuevo diseño único con función ergonómica.
- Bastidor de bomba portátil y compacto.
- Impulsor diseñado con sistema hidráulico de alta eficiencia.

MATERIALES

- Llave de la bomba: **Aluminio**
- Tubo: **Aluminio**



ÁREA DE TRABAJO

- Temperatura máx. del líquido: **40°C**
- Nivel de ruido: **106dB(A)**
- Combustible: **Gasolina**
- Depósito: **3,6L**



MODELO	DN Ø"		P ₂		ALTURA MÁX. m	CAUDAL MÁX. m ³ /h	ALT. ASP. m	MOTOR		PESO Kg	P.V.P.	B
	IMP.	ASP.	kW	Hp				Cilindrada	Tiempos			
ENG-50	2	2	5,2	7,0	26	33	7	212 cc	4	22,0	293,00	

MOTOBOMBA CENTRÍFUGA AUTOASPIRANTE SERIE ENG

DESCRIPCIÓN

- Motobomba de combustible de bajo consumo, útil para abastecimientos de agua y drenaje para fábricas, minas, así como para riego de campos, etc.
- Nuevo diseño único con función ergonómica.
- Bastidor de bomba portátil y compacto.
- Impulsor diseñado con sistema hidráulico de alta eficiencia.



MATERIALES

- Llave de la bomba: **Aluminio**
- Tubo: **Aluminio**



ÁREA DE TRABAJO

- Temperatura máx. del líquido: **40°C**
- Nivel de ruido: **106dB(A)**
- Combustible: **Gasolina**
- Depósito: **3,6L**

MODELO	DN Ø"		P ₂		ALTURA MÁX.	CAUDAL MÁX.	ALT. ASP.	MOTOR		PESO	P.V.P.
	IMP.	ASP.	kW	Hp	m	m ³ /h	m	Cilindrada	Tiempos	Kg	
ENG-80	3	3	5,2	7,0	28	60	7	212 cc	4	24,0	315,00

MOTOBOMBA CENTRÍFUGA AUTOASPIRANTE SERIE ENG

DESCRIPCIÓN

- Motobomba de combustible de bajo consumo, útil para abastecimientos de agua y drenaje para fábricas, minas, así como para riego de campos, etc.
- Nuevo diseño único con función ergonómica.
- Bastidor de bomba portátil y compacto.
- Impulsor diseñado con sistema hidráulico de alta eficiencia.
- Dispone de una salida frontal de 2" y dos salidas adicionales laterales de 1,5".



MATERIALES

- Llave de la bomba: **Aluminio**
- Tubo: **Aluminio**



ÁREA DE TRABAJO

- Temperatura máx. del líquido: **40°C**
- Nivel de ruido: **106dB(A)**
- Combustible: **Gasolina**
- Depósito: **3,6L**



3 SALIDAS

MODELO	DN Ø"		P ₂		ALTURA MÁX.	CAUDAL MÁX.	ALT. ASP.	MOTOR		PESO	P.V.P.
	IMP.	ASP.	kW	Hp	m	m ³ /h	m	Cilindrada	Tiempos	Kg	
ENG-50H-2	1 x 2" 2 x 1,5"	2	5,2	7,0	80	19	7	212 cc	4	26,0	405,00

ESQUEMA DE CONEXIÓN Y CÁLCULO

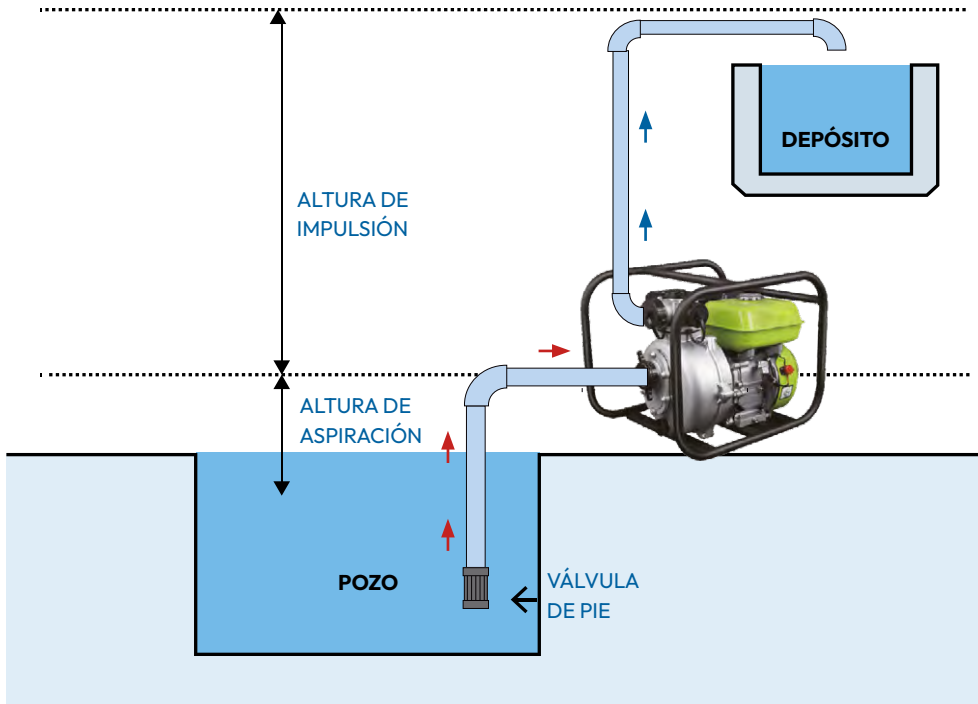

MOTOBOMBAS GASOLINA

Le aconsejamos que tenga en cuenta los siguientes parámetros para calcular el modelo de motobomba que necesita:



1. ALTURA DE ASPIRACIÓN

Todos los modelos están diseñados para alcanzar una capacidad máxima de aspiración de hasta **7 metros de profundidad** o longitud de tubería.

Para optimizar el rendimiento y garantizar una aspiración eficiente, es fundamental instalar una válvula de retención. **Se recomienda el uso de válvulas de clapeta o bola**, ya que ofrecen menor resistencia al flujo en comparación con las válvulas de muelle.

Asimismo, es esencial utilizar una manguera reforzada y resistente para evitar deformaciones o dobleces que puedan afectar el funcionamiento de la motobomba.

2. DISTANCIA DE TRASVASE

Metros de manguera desde la motobomba al lugar de trasvase.

3. ALTURA DE ELEVACIÓN/IMPULSIÓN

Se mide desde la motobomba hasta la altura máxima de trasvase.

4. PRESIÓN Y CAUDAL NECESARIOS

Una bomba que tenga fuerza de elevación de 65 metros corresponde a que ejerce una presión a la salida de la motobomba de 6,5kg/bar.



Con esta información, evaluaremos si la motobomba es adecuada para cumplir con los requerimientos específicos del trabajo.



AGUAS CARGADAS



PYD
ELECTROBOMBAS

DESCRIPCIÓN

- Electrobombas centrífugas monoetapa autoaspirantes de **impulsor abierto** para el trasiego de líquidos ligeramente cargados.
- Aptas para elevación o achique de aguas fangosas y ligeramente sucias.

MATERIALES

- Cuerpo de bomba: **Acero gris de fundición**
- Eje: **Acero INOX 420**
- Impulsor: **Acero gris de fundición**
- Cierre mecánico: **Graf/Óxido alum.**
- Soporte: **Acero gris de fundición**

ÁREA DE TRABAJO

- Temperatura máx. del líquido: **70°C**
- Grado de protección: **IP44**
- Aislamiento clase: **F**
- Servicio continuo



MODELO	DN	PASO	P ₂		TENSIÓN
	Ø"	mm	kW	Hp	V
B1½KQ-A	1 ½	12	0,75	1,0	230/400
B2KQ-A	2	16	1,1	1,5	230/400
B2KQ-A2	2	16	1,5	2,0	230/400
B3KQ-A	3	24	2,2	3,0	230/400
B3XR-A	3	18	4,0	5,5	400/690
B3XR-A2	3	23	5,5	7,5	400/690
B3XR-A3	3	23	7,5	10	400/690
B4XR-A	4	35	11	15	400/690
B4XR-A2	4	39	15	20	400/690
G3TMK-A	3	12	7,5	10	400/690
G3TMK-A2	3	15	11	15	400/690

		Q = CAUDAL (l/min)	H = ALTURA DE CARGA (m)			P.V.P.	D
		ESPECIFICACIONES HIDRÁULICAS				TRIF.	
Q	70	190	260	300	882,00		
H	16	12	9	6			
Q	60	200	320	390	871,00		
H	15	12	8	4			
Q	100	230	400	480	1.031,00		
H	18	15	10	5			
Q	200	500	740	900	1.114,00		
H	16	12	8	4			
Q	370	630	800	1100	2.937,00		
H	25	20	15	5			
Q	600	780	920	1320	3.840,00		
H	25	20	15	5			
Q	920	1250	1450	1650	4.515,00		
H	25	20	15	10			
Q	600	1900	2200	2350	6.512,00		
H	28	20	15	10			
Q	1200	1900	2350	2550	6.789,00		
H	28	25	20	15			
Q	400	600	900	1150	4.655,00		
H	38	35	25	15			
Q	500	800	1100	1300	5.702,00		
H	47	40	30	20			

Disponible bajo demanda versión con anillo de desgaste en acero inoxidable y cierre mecánico para aguas abrasivas, con compuerta de inspección.

DISPONIBLES EN
BRONCE Y ACERO INOXIDABLE*



*Disponible ejecución en bronce, acero inoxidable y tratada para hidrocarburos. Consulte suplementos y plazos con nuestro Dpto. comercial.



12V-24V MANUALES VOLUMÉTRICAS



ELECTROBOMBA 12V Y 24V SUMERGIBLE EN INOX

DESCRIPCIÓN

- Electrobomba sumergible compacta, diseñada para operar a 12V o 24V.
- Fabricada en **acero inoxidable** que garantiza una alta resistencia a la corrosión.
- Ideal para el trasiego de **aguas dulces/saladas y diésel**.
- Tamaño apto para aplicaciones en depósitos.

MATERIALES

- Fabricada completamente: **Acero INOX**
- Tubo de PVC incluido.



ÁREA DE TRABAJO

- Temperatura máx. del líquido: **35°C**
- Profundidad máx. de inmersión: **5 m**
- Grado de protección: **IP58**
- Aislamiento clase: **F**



APLICACIONES



PINZAS DE ARRANQUE INCLUIDAS

DATOS HIDRÁULICOS

MODELO	VELOCIDAD	CONSUMO	MEDIDAS			CAUDAL MÁXIMO	ALTURA MÁXIMA	P.V.P.	
	R.P.M.	W	Ø tubo	Ø bomba	cable	l/min	mca	12V	24V
OCEAN	8.500	20	19,0 mm	38 mm	0,5 mm 2 x 3 M	11	11	38,00	38,00

ELECTROBOMBAS 12V Y 24V SUMERGIBLES

DESCRIPCIÓN

- Electrobomba sumergible compacta, diseñada para operar a 12V o 24V.
- Aptas para el trasiego de **agua dulce y/o salada**, ideales para pequeñas embarcaciones.
- Equipadas con tamiz de plástico.

MATERIALES

- Fabricada completamente: **Materiales plásticos**



ÁREA DE TRABAJO

- Temperatura máx. del líquido: **35°C**
- Profundidad máx. de inmersión: **5 m**
- Grado de protección: **IP58**
- Aislamiento clase: **F**



PINZAS DE ARRANQUE INCLUIDAS

DATOS HIDRÁULICOS

MODELO	DN	I (A)		PESO	MEDIDAS (mm)			CAUDAL MÁXIMO	ALTURA MÁXIMA	P.V.P.	
	mm	12V	24V	Kg	largo	Ø	cable	l/min	mca	12V	24V
AMAZON 105	12,7	4,5	2,5	0,47	170	40	3.500	18	11	247,70	299,50
CONGO 111	19,0	6,0	3,0	0,56	170	40	3.500	32	9,7	312,10	377,30

ELECTROBOMBAS 12V Y 24V DE SUPERFICIE

DESCRIPCIÓN

- Electrobomba de superficie para trasiego de **agua dulce/salada, aceite y diésel**.
- Dispone de protección contra sobrecarga térmica que detiene automáticamente el motor en caso de exceso de carga, con función de re-arranque automático.
- El **filtro en la aspiración** dispone de una tapa transparente para comprobar la acumulación de residuos.



MATERIALES

- Cuerpo de bomba: **Materiales plásticos**
- Impulsor: **Materiales plásticos**
- Tomas de conexión: **Materiales plásticos**
- 4 tipos de filtros de entrada/salida para elegir.

ÁREA DE TRABAJO

- Temperatura máx. del líquido: **35°C**
- Trabajo en seco
- Autocebante



FILTRO ASPIRACIÓN



MÚLTIPLES BOQUILLAS



DATOS HIDRÁULICOS

MODELO	I (A)		CAUDAL MÁXIMO	ALTURA MÁXIMA	P.V.P.	
	12V	24V	l/min	mca	12V	24V
MARINE-1	6,0	2,9	17	28	147,00	147,00

ELECTROBOMBAS 12V Y 24V DE SUPERFICIE

DESCRIPCIÓN

- Electrobombas de corriente continua diseñadas para caudales discretos a elevadas presiones.
- Preparadas para arranque automático a través de presostato.



MATERIALES

- Cuerpo de bomba: **Materiales plásticos**
- Impulsor: **Materiales plásticos**
- Tomas de conexión: **Materiales plásticos**
- Carcasa de motor y base: **Aluminio**

ÁREA DE TRABAJO

- Temperatura máx. del líquido: **35°C**
- Grado de protección: **IP55**
- Aislamiento clase: **F**
- Tiempo máx. de trabajo en continuo: **15 minutos**



DATOS HIDRÁULICOS

MODELO	DN	I (A)		PESO	MEDIDAS (mm)			Q MÁX	H MÁX	ASP. MÁX	P.V.P.	
	ø"	12V	24V	Kg	ancho	alto	fondo	l/min	mca	mca	12V	24V
R3426348	3/8	-	4,5	3,4	92	90	242	7,6	16	2,5	-	210,00
R3526144	3/8	9,0	-	3,5	91	93	240	11,0	34	2,5	213,00	-
R3626344	3/8	-	5,0	3,5	91	93	240	11,0	26	2,5	-	224,00

ELECTROBOMBAS 12V ACHIQUE PORTÁTILES

DESCRIPCIÓN

- Electrobombas de corriente continua para achique de aguas poco cargadas, saladas, sentinas de barcos, etc.

MATERIALES

- Carcasa exterior: **Plástico**
- Eje: **Acero INOX**
- Impulsor: **Plástico**
- Base: **Plástico**

ÁREA DE TRABAJO

- Temperatura máx. del líquido: **35°C**
- Profundidad máx. de inmersión: **3 m**
- Grado de protección: **IP68**
- Aislamiento clase: **F**



TMC 04301

TMC 04302

TMC 03/06

DATOS HIDRÁULICOS

MODELO	DN		I (A)	CANTIDAD	MEDIDAS (mm)		CAUDAL MÁXIMO	ALTURA MÁXIMA	P.V.P. ^C
	mm	12V			uds.	altura			
TMC 04301	11		2,0	100	103,5	40,2	7,5	4,85	22,90
TMC 04302	9	11	2,5	100	105	54,4	12	4,55	22,90
TMC 03305	24	36	4,0	6	165	107	63	2,40	68,30
TMC 03608		36	10,0	12	194	140	110,4	3,95	103,50
TMC 06605	36	40	18,0	30	239,2	157	158	3,95	156,50

BOMBA AUTOCEBANTE MANUAL

DESCRIPCIÓN

- Bomba manual autocebante de membrana simple de accionamiento mecánico.
- Mango con dos posiciones.
- Apta para **aguas saladas, agua de sentina, aguas residuales**, etc.
- Uso doméstico, embarcaciones, autocaravanas, etc.

MATERIALES

- Adaptador y racord de conexión: **Materiales plásticos**
- Manivela y boquilla: **Acero INOX**

ÁREA DE TRABAJO

- Temperatura máx. del líquido: **35°C**



DATOS HIDRÁULICOS

MODELO	DN	CAUDAL MÁXIMO		P.V.P. ^C
	mm	l/min		
TMC 71601	32	45,4		69,40

ELECTROBOMBAS 12V Y 24V SERIE TMC

DESCRIPCIÓN

- Electrobombas autocebantes diseñadas para trasiego a caudales discretos de aguas limpias libres de sólidos.
- Modelo TMC 06203 con conexiones de espiga y modelo TMC 06204 con conexión de rosca JIC.

MATERIALES

- Envoltente del motor: **Aluminio**
- Base: **Aluminio**
- Impulsor: **Flexible en NBR**
- Cuerpo: **Plástico alta resistencia**



ÁREA DE TRABAJO

- Temperatura máx. del líquido: **35°**
- Grado de protección: **IP55**
- Aislamiento clase: **F**



IMPULSOR



DATOS HIDRÁULICOS

MODELO	DN mm	CONEX. tipo	I (A)		PESO Kg	MEDIDAS (mm)			Q _{MÁX} l/min	H _{MÁX} mts.	ASP. _{MÁX} mts.	P.V.P.	
			12V	24V		ancho	alto	fondo				12V	24V
TMC 06203	25	espiga	8,0	4,0	2,8	172	97	128	25,2	4	Consulte con nuestro dpto. comercial	136,80	138,80
TMC 06204	25	rosca JIC	8,0	4,0	2,8	172	97	128	25,2	4	Consulte con nuestro dpto. comercial	137,10	139,10

ELECTROBOMBAS 12V Y 24V LATÓN SERIE TMC

DESCRIPCIÓN

- Electrobombas autocebantes diseñadas para trasiego a caudales discretos de aguas limpias libres de sólidos.
- Arranque automático a través de presostato (incluido en TMC 06202)
- Conexiones rosca JIC.

MATERIALES

- Envoltente del motor: **Aluminio**
- Base: **Aluminio**
- Impulsor: **Flexible en NBR**
- Cuerpo: **Latón**



ÁREA DE TRABAJO

- Temperatura máx. del líquido: **35°**
- Grado de protección: **IP55**
- Aislamiento clase: **F**



IMPULSOR



TMC 06201

TMC 06202

DATOS HIDRÁULICOS

MODELO	DN mm	CONEX. tipo	I (A)		PESO Kg	MEDIDAS (mm)			Q _{MÁX} l/min	H _{MÁX} mts.	ASP. _{MÁX} mts.	P.V.P.	
			12V	24V		ancho	alto	fondo				12V	24V
TMC 06201	25	rosca JIC	8,0	4,0	2,8	172	97	128	25,2	4	Consulte con nuestro dpto. comercial	220,20	222,20
TMC 06202	25	rosca JIC	8,0	4,0	2,8	168	97	201	25,2	4	Consulte con nuestro dpto. comercial	266,60	268,60



DESCRIPCIÓN

- Presostato de arranque.
- Activa la bomba cuando la presión desciende por debajo de 0,5 bar.
- Compatible con modelos: **TMC 06201 y TMC 06202.**



DESCRIPCIÓN

- Impulsor en NBR de recambio.
- Compatible con modelos: **TMC 06201, TMC 06202, TMC 06203 y TMC 06204.**

TIPO	P.V.P.
TMC 00006	67,00

TIPO	Ø	P.V.P.
TMC 06211	50,7 mm	15,12

ELECTROBOMBA 12V Y 24V BRONCE SERIE TMC

DESCRIPCIÓN

- Electrobomba autocebante diseñada para trasiego a caudales discretos de **gasóleos, lubricantes ligeros, anticongelantes o aceites de motor con viscosidad por debajo de ISO 32.**
- Apta para transferencia y vaciado de depósitos de gasóleo, repostaje de tractores, maquinaria agrícola o achique para barcos.
- Conexiones en espiga.

MATERIALES

- Envoltente del motor: **Aluminio**
- Base: **Aluminio**
- Impulsor: **Engranajes en bronce**
- Cuerpo: **Bronce**

ÁREA DE TRABAJO

- Temperatura máx. del líquido: **35°**
- Grado de protección: **IP55**
- Aislamiento clase: **F**



TMC 6010101



FILTRO ASPIRACIÓN



IMPULSOR ENGRANAJES



DATOS HIDRÁULICOS

MODELO	DN	CONEX.	I (A)		PESO	MEDIDAS (mm)			Q _{MÁX}	H _{MÁX}	ASP _{MÁX}	P.V.P.	
	mm	tipo	12V	24V	Kg	ancho	alto	fondo	l/min	mts.	mts.	12V	24V
TMC 6010101	15,8	espiga	14,0	7,0	2,5	173	95	340	25,2	20	1,5	335,90	339,50

⚠️ **AVISO:** No utilizar en presencia de vapores inflamables.

ELECTROBOMBA VOLUMÉTRICA PARA GASÓLEO SERIE MD

DESCRIPCIÓN

- Electrobomba volumétrica de **anillo líquido con rodete en estrella** que otorga a la bomba una notable capacidad aspirante.
- Apropiaada para trasiego de líquidos, incluso volátiles.
- Cuerpo con **tapa frontal de latón** para reducir el riesgo de bloqueo.

MATERIALES

- Cuerpo de bomba: **Fundición y latón**
- Eje: **Acero INOX 416**
- Impulsor: **Latón**
- Soporte motor: **Fundición**
- Cierre: **Especial para gasoil**

ÁREA DE TRABAJO

- Temperatura máx. del líquido: **90°C**
- Grado de protección: **IPX4**
- Aislamiento clase: **F**



CAUDAL

m ³ /h	0,3	0,6	1,2	1,8	2,4	2,7
l/min	5	10	20	30	40	45

MODELO	P ₂		DN	I (A)		PESO	ALTURA DE CARGA EN METROS					P.V.P.		
	kW	Hp	Ø"	1~230V	3~400V	Kg						MONOF.	TRIF.	
MD-100	0,75	1,0	1	5,4	2,1	11,6	53	48	37	25	13,5	9	365,00	365,00



ARRASTRE MAGNÉTICO



DESCRIPCIÓN

- Electrobombas centrífugas con acoplamiento magnético, **herméticamente estancas**, con diversas aplicaciones en las industrias química, farmacéutica, minerosiderúrgica, etc.
- Modelos con tensión monofásica, excepto la Serie 400 (trifásica).
- Varios modelos disponibles con conexión en rosca Gas, tubo y/o brida.



MATERIALES

- Partes mojadas: **Polipropileno**



ÁREA DE TRABAJO

- Temperatura máx. del líquido: **40°C**
- Peso específico: **Menor de 1,3 kg/dm³**
- Viscosidad: **Menor de 30 cp**



TRABAJO EN
50Hz Y 60Hz

		CAUDAL										
I/hora	0	120	240	360	480	600	720	960	1200	1440	1680	1920
I/min	0	2	4	6	8	10	12	16	20	24	28	32

MODELO	P ₂		DN (mm)		DN (Ø")		CAUDAL											P.V.P. F
	W	ASP.	IMP.	ASP.	IMP.	ALTURA DE CARGA EN METROS											MONOF.	
PD-6R	3,0	14	14	-	-	1	0,6	0,6	0,4	0,1								112,00
PD-10R	6,0	14	14	-	-	1,6	1,5	1,3	1	0,7	0,3						116,00	
PD-15R	10	14	14	-	-	2,7	2,4	2,1	1,8	1,5	1,3	1				118,00		
PD-20R	20	18	18	-	-	3,2	3,2	3,1	3	2,9	2,8	2,6	2,3	1,7	0,9	131,00		
PD-30R(M)	45	20	20	G3/4	G3/4	3,9	3,8	3,6	3,5	3,3	3,1	2,9	2,5	2,1	1,5	0,9	0,2	159,00
PD-30RZ	45	18	18	-	-	8	7,8	7,5	7,1	6,6	5,9	5	0,2					162,00

Modelos "RM" = Conexión tipo rosca G. Modelos "R" = Conexión tipo tubo. Modelo "RZ" = Conexión de tubo

		CAUDAL										
I/hora	0	600	1200	1800	2400	3000	3600	4800	6000	7200	8400	9000
I/min	0	10	20	30	40	50	60	80	100	120	140	150

MODELO	P ₂		DN (mm)		DN (Ø")		CAUDAL											P.V.P. F
	W	ASP.	IMP.	ASP.	IMP.	ALTURA DE CARGA EN METROS											MONOF.	
PD-40RM	65	-	-	G1	G1	4,6	4,6	4,1	3,1	1,4							183,00	
PD-55RM	90	-	-	G1	G1	5,6	5,4	4,9	4,1	3,1	1,8	0,2					214,00	
PD-70RM	150	-	-	G1	G1	6,6	6,3	6	5,6	5	4,2	3,4	0,9				256,00	
PD-70RZ	180	20	20	-	-	14,3	14,2	13	10,3	0,1						263,00		
PD-100RM	260	-	-	G1	G1	8,8	8,7	8,5	8,2	8	7,5	6,9	5,1	2,9	0,1			308,00
PD-120R	270	40	40	-	-	8,3	8	7,8	7,4	7	6,7	6,2	5,3	4,2	3,0	1,2	0,1	380,00

Modelos "RM" = Conexión tipo rosca G. Modelos "R" = Conexión tipo tubo. Modelo "RZ" = Conexión de tubo

		CAUDAL										
I/hora	0	1500	3000	4500	6000	7500	9000	10500	12000	13500	15000	
I/min	0	25	50	75	100	125	150	175	200	225	250	

MODELO	P ₂		DN (Ø")		CAUDAL											P.V.P. F
	W	ASP.	IMP.	ALTURA DE CARGA EN METROS											TRIF.	
PD-400R	400	1 ½	1 ½	10 8,5 6,4 3,6 0,1											428,00	
PD-401	750	1 ½	1 ½	14 13,1 11,9 9,8 7,3 4,2 0,1											463,00	
PD-402	1500	1 ½	1 ½	20 19,5 18,1 16,5 14,2 11,7 8,8 5,1 0,1											498,00	
PD-403	2200	1 ½	1 ½	23 22,8 22,3 21,5 20,1 18,5 16,3 13,5 10 5,9 0,2											541,00	

Conexión: Tipo rosca macho. Incluye accesorios: Brida roscada y racores tipo espiga



SOPLANTES
AGITADORES
DOSIFICADORAS



SOPLANTES SERIE BLOW

DESCRIPCIÓN

- Electrobombas soplantes fabricadas en **aluminio de alta calidad**.
- Para aplicaciones tanto domésticas como piscinas, baños de burbujas, extractores de humos e industriales como secado rápido, aspiración, limpieza de gases, etc.
- Gracias a su diseño no requieren de mantenimiento.



MATERIALES

- Cuerpo: **Aluminio**
- Turbina: **Aluminio**
- Eje: **Acero 45 (cojinete de alta temperatura)**
- Base: **Hierro**
- Motor: **Completamente en cobre**

ÁREA DE TRABAJO

- Temperatura ambiente: **Hasta 40°C**
- Trabajo horizontal: **Admitido**
- Compatible con la mayoría de gases (aire, oxígeno, CO₂)



FILTRO SILENCIADOR DE FIBRA



BAJO CONSUMO

MODELO	P ₂		VELOCIDAD	CAUDAL MÁX.	PRESIÓN MÁX.		NIVEL SONORO	CONEXIONES*		VOLTAJE	I (A)		P.V.P.	
	kW	Hp	RPM	m ³ /h	Positivo (Kpa)	Negativo (Kpa)	db	mm	DN	V	1~230V	3~400V	MONOF.	TRIF.
BLOW-370	0,37	0,5	2.800	80	16	11	≤60	40	1 1/4"	230 / 400	2,1	0,74	256,20	250,80
BLOW-750	0,75	1,0	2.800	150	22	20	≤60	50	1 1/2"	230 / 400	4,3	1,5	328,30	323,00
BLOW-1100	1,1	1,5	2.800	220	25	22	≤60	60	2"	230 / 400	6,2	2,2	437,30	427,10
BLOW-1500	1,5	2,0	2.800	240	27	24	≤60	60	2"	230 / 400	8,5	3,0	442,10	442,10
BLOW-2200	2,2	3,0	2.800	325	36	33	≤70	60	2"	230 / 400	12,5	4,4	638,20	561,20
BLOW-3000	3,0	4,0	2.800	390	38	35	≤70	60	2"	380	-	6,0	-	623,20
BLOW-4000	4,0	5,4	2.800	480	45	41	≤70	75	2 1/2"	380	-	8,0	-	1.108,40
BLOW-5500	5,5	7,4	2.800	530	50	48	≤70	75	2 1/2"	380	-	11,0	-	1.342,70
BLOW-7500	7,5	10,0	2.800	550	56	51	≤70	75	2 1/2"	380	-	15,0	-	1.418,80
BLOW-11000	11,0	15,0	2.800	1100	80	56	≤70	111	4"	380	-	22,0	-	2.894,20
BLOW-15000	15,0	20,0	2.800	1150	85	58	≤70	111	4"	380	-	30,0	-	3.041,40
BLOW-18500	18,5	25,0	2.800	1200	90	60	≤70	111	4"	380	-	37,0	-	3.188,60

(*) Conexión en "mm" corresponde al diámetro exterior (ON).

APLICACIONES

<p>ASPIRACIÓN DE AIRES DE GASÓLEO</p>	<p>LAVADO DE ENVASES POR SECADO</p>	<p>AIREACIÓN A LA FERMENTACIÓN DE ABONO</p>
<p>SECADO FORZADO PARA IMPRESIÓN</p>	<p>LAVADO/SECADO PARA VEHÍCULOS</p>	<p>SUMINISTRO DE AIRE PARA ACUICULTURA</p>

SOPLANTES SERIE BLOW

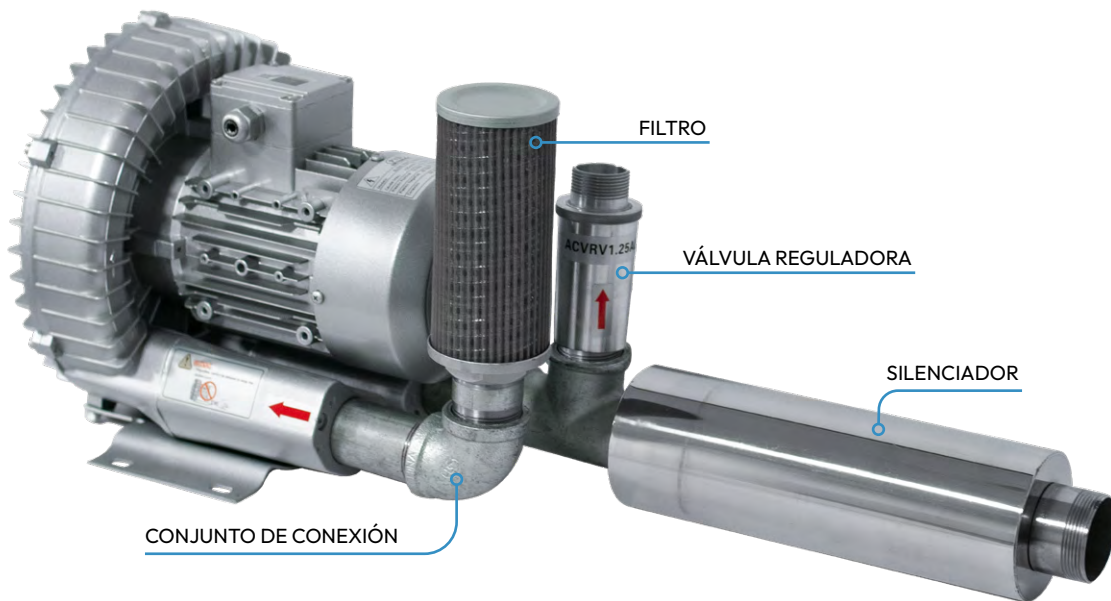

ACCESORIOS PARA BOMBA SOPLANTE



FILTRO DEPÓSITO

MODELO	DN	P.V.P. ^C
BLOW656.2411/4	1-1/4"	21,00
BLOW656.2411/2	1-1/2"	42,00
BLOW656.242	2"	63,00
BLOW656.2421/2	2-1/2"	63,00



FILTRO MALLA

MODELO	DN	P.V.P. ^C
BLOW656.2311/4	1-1/4"	68,00
BLOW656.2311/2	1-1/2"	92,00
BLOW656.232	2"	157,00
BLOW656.2321/2	2-1/2"	199,00



VÁLVULA REGULADORA DE PRESIÓN PLÁSTICO

MODELO	DN	P.V.P. ^C
BLOW656.25	1-1/4"	58,00



VÁLVULA REGULADORA DE PRESIÓN METAL

MODELO	DN	P.V.P. ^C
BLOW656.26	1-1/4"	121,00



SILENCIADOR

MODELO	DN	P.V.P. ^C
BLOW656.2111/4	1-1/4"	16,00
BLOW656.2111/2	1-1/2"	26,00
BLOW656.212	2"	36,00
BLOW656.2121/2	2-1/2"	58,00



CONJUNTO DE CONEXIÓN

MODELO	DN	P.V.P. ^C
BLOW656.2211/4	1-1/4"	60,00
BLOW656.2211/2	1-1/2"	71,00
BLOW656.222	2"	78,00
BLOW656.2221/2	2-1/2"	121,00

ELECTROBOMBA DOSIFICADORA DE PH/COLORO

DESCRIPCIÓN

- Electro bomba dosificadora de membrana que funciona con un microprocesador para administrar la dosificación.
- Su exterior con IP65 garantiza una protección frente a salpicaduras de agua.

MATERIALES

- Carcasa exterior: **Materiales plásticos**
- Membrana: **PTFE**
- Cabezal: **PVDF-T**

ÁREA DE TRABAJO

- Grado de protección: **IP65**



MODELO	Impulsos/min ⁻¹	CAUDAL				P.V.P. C
		l/h	bar	l/h	bar	MONOF.
KOMPACT	160	5	8,00	3	10,00	244,00

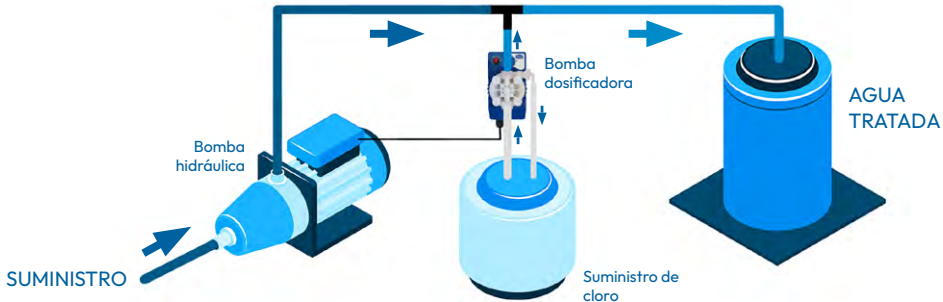

ELECTROBOMBAS DOSIFICADORAS DE MEMBRANA SERIE BA

DESCRIPCIÓN

- Electro bombas dosificadoras de membrana a prueba de fugas.
- Todos los modelos tienen longitud de carrera ajustable manualmente a bomba parada, permitiendo el ajuste del 20% al 100% de la capacidad nominal.

MATERIALES

- Membrana y asiento de la válvula: **Vitón**
- Bola: **Cerámica**
- Juntas: **Caucho sintético**

APLICACIONES

- Tratamientos de aguas y de afluentes
- Adición de detergentes
- Biocidas
- Lubricantes
- Desnaturalizantes de pintura
- Productos químicos de pretratamiento de metal
- Neutralización



MODELO	P ₂	TENSIÓN	PESO	NÚMERO DE EMBOLADAS	LARGO EMBOLADA	CAUDAL MÁXIMO	PRESIÓN MÁXIMA	P.V.P. F
	W	V		min ⁻¹	mm	l/hora	bar	
NIKKISO BA 03	15	24 VDC	2,7	43	2,8	4,5	10	379,00

ELECTROBOMBAS DOSIFICADORAS DE PISTÓN



DESCRIPCIÓN

- Electrobombas dosificadoras de pistón PVC y en acero **INOX 316** para tensión trifásica, con ajuste de la dosificación mediante control manual giratorio en escala 0 - 100%.
- Ideales para aplicaciones que requieren alta presión y caudales controlados con gran precisión.

MATERIALES

PVC:

- Cabeza bomba: **PVC**
- Válvulas: **Cerámica**
- Asiento de válvulas: **PVC**
- Junta de válvulas y empaquetadura de pistón: **FPM (Vitón)**

INOX:

- Cabezal, pistón, : **Acero INOX 316**
- Válvulas: **Acero INOX 316**
- Asiento de válvula: **PVdF**
- Juntas de válvulas y empaquetadura de pistón: **FPM (Vitón)**

ÁREA DE TRABAJO

- Grado de protección: **IP55**
- Aislamiento clase: **F**



PVC

MODELO	MATERIALES		P ₂		VÁLVULAS
	CONSTRUC.	kW	Hp	Ø"	
AP0077BA00100	PVC	0,18	0,25	1/2	
AP112BA00A000	PVC	0,25	0,34	1/2	
AP225BA00A000	PVC	0,25	0,34	1/2	
BP0128BA000000	PVC	0,25	0,34	3/4	
BP0256BA000000	PVC	0,25	0,34	3/4	
BP0256BA006000	PVC	0,37	0,5	3/4	
BP0431BA006000	PVC	0,37	0,5	1	
BP0503BA006000	PVC	0,37	0,5	1	

CAUDAL MÁX. (l/h)		PRESIÓN MÁX.		Nº DE IMPULSOS		P.V.P. ^D
l/hora		bar		min ⁻¹		
50 Hz	60 Hz	50 Hz	60 Hz	50 Hz	60 Hz	
77	-	10,0	-	120	-	1.026,00
112	134	6,0	6,0	60	72	1.284,00
225	-	6,0	-	120	-	1.284,00
128	153	10,0	9,5	60	72	1.473,00
256	-	7,5	-	120	-	1.473,00
256	-	10,0	-	120	-	1.567,00
431	512	7,0	5,5	103	122	1.824,00
503	-	6,0	-	120	-	1.824,00

INOX

MODELO	MATERIALES		P ₂		VÁLVULAS
	CONSTRUC.	kW	Hp	Ø"	
AP0077AA00100	INOX	0,18	0,25	1/2	
AP112AA00A000	INOX	0,25	0,34	1/2	
AP225AA00A000	INOX	0,25	0,34	1/2	
BP0128AA000000	INOX	0,25	0,34	3/4	
BP0256AA000000	INOX	0,25	0,34	3/4	
BP0256AA006000	INOX	0,37	0,5	3/4	
BP0431AA006000	INOX	0,37	0,5	1	
BP0503AA006000	INOX	0,37	0,5	1	

CAUDAL MÁX. (l/h)		PRESIÓN MÁX.		Nº DE IMPULSOS		P.V.P. ^D
l/hora		bar		min ⁻¹		
50 Hz	60 Hz	50 Hz	60 Hz	50 Hz	60 Hz	
77	-	10,0	-	120	-	1.177,00
112	134	6,0	6,0	60	72	1.435,00
225	-	6,0	-	120	-	1.435,00
128	153	12,0	9,5	60	72	1.497,00
256	-	7,5	-	120	-	1.497,00
256	-	13,0	-	120	-	1.562,00
431	512	7,0	5,5	103	122	1.889,00
503	-	6,0	-	120	-	1.889,00

AGITADORES

DESCRIPCIÓN

- Agitadores de construcción compacta, con motores eléctricos trifásicos 380V fuera del depósito, conectados mediante eje de longitud determinada (máx. 80 cm).
- Velocidad reducida.
- Hélice de tres álabes en el extremo.

MATERIALES

- Motor: **Asíncrono 50 Hz**
- Carcasa del motor: **Aluminio**
- Soporte de motor: **Fundición de aluminio**
- Eje: **Acero INOX 304 (agitador)**
- Hélice: **Acero INOX 304**



MODELO	P		R.P.M.	FRECUENCIA	P.V.P. F
	kw	Hp			
AG6P-050	0,35	0,50	1.000	50	676,60
AG4P-050*	0,35	0,50	1.400	50	699,00
AG6P-075	0,55	0,75	1.000	50	688,60
BASE-AGI	Soporte para agitador				59,00

(*) Modelo AG4P-050 incorpora motor IE2

DEPÓSITOS DE POLIETILENO

DESCRIPCIÓN

- Depósitos de acumulación de diferentes capacidades con soporte para bomba dosificadora o removedor.
- Todos los depósitos tienen tapa e indicaciones de nivel de líquido.

MATERIALES

MODELO R31 (Cilíndrico):

- Fabricados: **Polietileno aditivado anti-UV, calidad alimentario (registro sanitario)**
- Acabado: **Blanco natural y tapa roscada negra.**

MODELO R25 (Cónico):

- Fabricados: **Polietileno aditivado anti-UV, calidad alimentario (registro sanitario)**
- Acabado: **Blanco natural**



MODELO	CAPACIDAD	DIMENSIONES (mm)			TAPA (Ø)	P.V.P. F
		L	Ø	ALTURA	mm	
R310050	50	375	680	160	116,00	
R310100	100	475	655	160	151,00	
R310230	230	575	945	230	214,00	
R310335	335	652	1.124	165	368,00	
R310580	580	790	1.215	230	397,00	
R311050	1.050	995	1.450	300	563,00	

MODELO	CAPACIDAD	DIMENSIONES (mm)			TAPA (Ø)	P.V.P. F	
		L	Ø	ALTURA	mm	Depósito	Tapa
R250200	200	650	890	570	153,00	22,00	
R250500	500	880	1.100	920	265,00	41,00	
R251000	1.000	1.170	1.310	1.200	373,00	61,00	
R251500*	1.500	1.400	1.130	-	659,00	-	
R252000	2.000	1.715	1.150	1.750	769,00	154,00	
R253000	3.000	1.840	1.440	1.880	1.231,00	308,00	

(*) Tapa no disponible

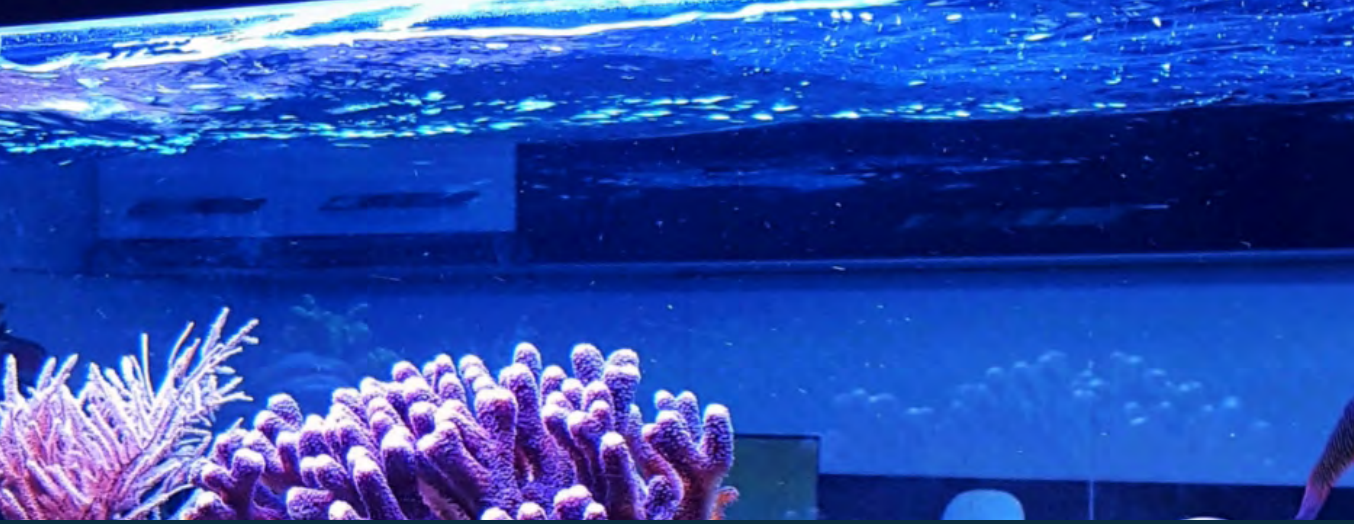

FUENTE ACUARIOS



DECORATIVAS PARA FUENTES, ESTANQUES Y ACUARIOS

DESCRIPCIÓN

- Fabricadas conforme a las normas internacionales de seguridad más exigentes, la serie **Multi** funciona en modalidad **Wet&Dry** (excepto el modelo 800).
- De fácil mantenimiento, sorprenden por sus elevadas prestaciones y seguridad.
- Incluyen cable de alimentación de 1,5 metros con enchufe Schuko.



MULTI 800

- Su bajo peso permite la colocación sobre cristal gracias a las ventosas que incluye en su base. Funcionamiento bajo superficie.



P ₂	I	SALIDA	Q MÁX	H MÁX	MEDIDAS	P.V.P. ^A
W	A	Ø"	l/hora	m	mm	MONOF.
13	0,10	1/2	750	1,50	61 x 86 x 54	47,10

MULTI 1300

- La entrada de agua roscada permite el acoplamiento de filtros York.



P ₂	I	SALIDA	Q MÁX	H MÁX	MEDIDAS	P.V.P. ^A
W	A	Ø"	l/hora	m	mm	MONOF.
20	0,20	1/2	1.200	1,70	71 x 86 x 70	58,90

MULTI 2500

- Se puede vincular a una precámara con esponja para crear cascadas. Entrada de agua roscada.



P ₂	I	SALIDA	Q MÁX	H MÁX	MEDIDAS	P.V.P. ^A
W	A	Ø"	l/hora	m	mm	MONOF.
50	0,51	1	2.500	2,80	96 x 131 x 104	99,50

MULTI 4000

- Se puede vincular a una precámara con esponja para crear cascadas. Entrada de agua roscada.



P ₂	CONSUMO	SALIDA	Q MÁX	H MÁX	MEDIDAS	P.V.P. ^A
W	A	Ø"	l/hora	m	mm	MONOF.
52	0,64	1	3.800	3,10	96 x 131 x 104	116,20

MULTI 5800

- Se puede vincular a una precámara con esponja para crear cascadas. Entrada de agua roscada.



P ₂	I	SALIDA	Q MÁX	H MÁX	MEDIDAS	P.V.P. ^A
W	A	Ø"	l/hora	m	mm	MONOF.
90	0,80	1	5.800	3,80	111 x 160 x 133	158,50

DESCRIPCIÓN

- Fabricadas conforme a las normas internacionales de seguridad más exigentes, permiten regulación de caudal de forma manual.
- Todos los modelos incluyen ventosas para una fijación en superficies no porosas y un cable de alimentación de 1,5 metros con enchufe Schuko.



MICRA

- Su bajo peso permite la colocación sobre cristal gracias a las ventosas que incluye en su base. Funcionamiento bajo superficie.



P ₂	I	SALIDA	Q MÁX	H MÁX	MEDIDAS	P.V.P. ^A
W	A	Ø"	l/hora	m	mm	MONOF.
6	0,04	1/2	400	0,60	43 x 57 x 52	26,25

MICRA PLUS

- La entrada de agua roscada permite el acoplamiento de filtros York.



P ₂	I	SALIDA	Q MÁX	H MÁX	MEDIDAS	P.V.P. ^A
W	A	Ø"	l/hora	m	mm	MONOF.
6,50	0,04	1/2	600	0,85	43 x 57 x 52	27,70

NOVA

- Se puede vincular a una precámara con esponja para crear cascadas.



P ₂	I	SALIDA	Q MÁX	H MÁX	MEDIDAS	P.V.P. ^A
W	A	Ø"	l/hora	m	mm	MONOF.
10	0,07	1/2	800	1,60	46 x 60 x 61	44,70

IDRA

- Se puede vincular a una precámara con esponja para crear cascadas.



P ₂	I	SALIDA	Q MÁX	H MÁX	MEDIDAS	P.V.P. ^A
W	A	Ø"	l/hora	m	mm	MONOF.
22	0,20	1/2	1.300	2,20	86 x 83 x 72	56,50

EXTREMA

- Se puede vincular a una precámara con esponja para crear cascadas.



P ₂	I	SALIDA	Q MÁX	H MÁX	MEDIDAS	P.V.P. ^A
W	A	Ø"	l/hora	m	mm	MONOF.
32	0,50	3/4	2.500	2,50	108 x 104 x 72	87,00

FARO HALLEY

DESCRIPCIÓN

- Faro halógeno orientable para lagos, fuentes y estanques **totalmente sumergible**.
- Incluye tres lentes de color fácilmente intercambiables.
- Se suministra con 1,5 metros de cable y enchufe Schuko con transformador.



EXTERIOR



INTERIOR



LENTE
INTERCAMBIABLES



MODELO	POTENCIA W	INLUMINACIÓN SEGÚN PROFUNDIDAD (lumen/m ²)				MEDIDAS mm	P.V.P. ^A MONOF.
		1 m	2 m	3 m	4 m		
FARO	20	600	150	67	38	240 x 136 x 188	86,80

ACCESORIOS PARA FUENTES, ESTANQUES Y ACUARIOS



BOQUILLAS



WATERBELL



DAISY

MODELO	EFEECTO	P.V.P. ^A
90626	DAISY	5,70
90620/A	WATERBELL	7,70

BOQUILLAS + TELESCÓPICO



MODELO	USO	P.V.P. ^A
SKT0024	MULTI 800	12,40
SKT0025	MULTI 1300	12,40

TUBO TELESCÓPICO



MODELO	USO	P.V.P. ^A
90655	MODELO IDRA	9,60
90675	MULTI EXTREMA	9,60

KIT DE IMPULSIÓN



MODELO	USO	P.V.P. ^A
ACS000	MICRA Y MICRA+	12,80
SKT0030	MULTI 2500 MULTI 4000 MULTI 5800	22,80

PISCINA



PYD
ELECTROBOMBAS

ELECTROBOMBA RECIRCULADORA PARA PISCINA SERIE POOL

DESCRIPCIÓN

- Electrobombas diseñadas para la recirculación eficiente en piscinas domésticas, estanques, fuentes, aguas cloradas.
- Fabricación robusta apta para el trasiego de **aguas salobres y saladas**.



MATERIALES

- Cuerpo de bomba y pie: **PP con fibra de vidrio**
- Carcasa motor: **Aluminio L-2521**
- Eje: **Acero INOX 420**
- Impulsor: **PPO**
- Difusor: **PP con fibra de vidrio**
- Cierre mecánico: **Sic/Sic**

ÁREA DE TRABAJO

- Temperatura máx. del líquido: **40°C**
- Grado de protección: **IP55**
- Agua limpia con partículas en suspensión
- Autoaspirante: **Hasta 2 m con válvula de pie**



m ³ /h	CAUDAL											
	0	2	4	6	8	10	12	14	16	18	22	24
l/min	0	33	66	100	133	166	200	233	266	300	366	400

MODELO	DN		P ₂		P ₁		I (A)		PESO		P.V.P.		B								
	mm	kW	Hp	W	1~230V	3~400V	Kg	ALTURA DE CARGA EN METROS		MONOF.	TRIF.										
POOL-25	50	0,18	0,25	370	1,9	-	9,3	7	6,5	5,5	5	4	220,00	-							
POOL-33	50	0,25	0,33	550	2,7	-	9,5	10	9,8	9,3	8,5	7,5	6,5	4,5	3	235,00	-				
POOL-50	50	0,37	0,5	750	3,8	-	9,7	13	12,7	12,6	12,5	12,5	12	11	9	8	7	3,5	282,00	-	
POOL-75	50	0,55	0,75	900	4,6	1,8	10,5	15,2	15,1	15	14,7	14	13	12	11	9	8	3,5	301,00	329,00	
POOL-100	50	0,75	1,0	1.100	5,8	2,1	10,9	17,5	17	16,7	16,5	16	14,7	13,7	12	11	9	4	319,00	337,00	
POOL-150	50	1,1	1,5	1.500	7,0	2,6	11,5	18,2	18	17,7	17,5	17	16	15	14	13	11,5	4	2	336,00	345,00

ESQUEMA DE INSTALACIÓN BOMBA DE PISCINA

1. Skimmer
2. Sumidero
3. Limpiafondos
4. Electrobomba
5. Válvula selectora
6. Filtro
7. Retorno

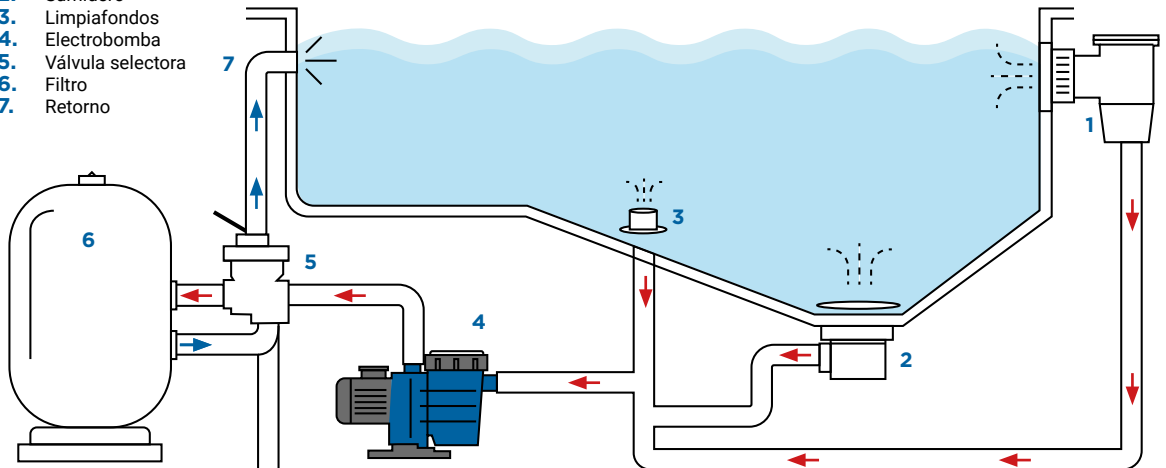

ELECTROBOMBA RECIRCULADORA PARA PISCINA SERIE POOL2

DESCRIPCIÓN

- Electrobombas diseñadas para la recirculación eficiente en piscinas domésticas, estanques, fuentes, aguas cloradas.
- Fabricación robusta apta para el trasiego de **aguas salobres y saladas**.

MATERIALES

- Cuerpo de bomba y pie: **PP con fibra de vidrio**
- Carcasa motor: **Aluminio L-2521**
- Eje: **Acero INOX 420**
- Impulsor: **PPO**
- Difusor: **PP con fibra de vidrio**
- Cierre mecánico: **Sic/Sic**

ÁREA DE TRABAJO

- Grado de protección: **IP55**
- Aislamiento clase: **F**
- Agua limpia con partículas en suspensión



TAPADERA TRANSPARENTE



FILTRO DE CESTA



MODELO	DN mm	P ₂		I (A)		PESO Kg	CAUDAL							P.V.P.												
		kW	Hp	1~230V	3~400V		m ³ /h								MONOF.	TRIF.										
POOL2-150	63	1,1	1,5	5,2	2,0	16,5	0	6	12	18	21	24	30	0	100	200	300	350	400	500	14	17	20	390,00	380,00	
POOL2-200	63	1,5	2,0	7,0	2,5	18,8																				
POOL2-300	63	2,2	3,0	10,0	3,9	22,0																				



VISITE NUESTRA WEB
 PARA OBTENER MÁS
 INFORMACIÓN TÉCNICA
 DE NUESTROS PRODUCTOS



Capture el **código QR**
 para acceder a nuestra web.

BOMBAS CENTRÍFUGAS PISCINA GRANDES DIMENSIONES INOX SERIE SCA

DESCRIPCIÓN

- Electrobombas con prefiltro para recirculación y filtración de agua en grandes y medianas piscinas, piscinas públicas, atracciones acuáticas y similares.
- **Gran caudal**, gran elevación, funcionamiento silencioso, **alta eficiencia** y ahorro de energía.



MATERIALES

- Cuerpo de bomba: **Acero INOX 304**
- Eje: **Acero INOX 304**
- Impulsor: **Acero INOX 304**
- Prefiltro: **Acero INOX 304**

ÁREA DE TRABAJO

- Temperatura máx. del líquido: **70°C**
- Grado de protección: **IP55**
- Aislamiento clase: **F**
- Servicio continuo



m³/h	CAUDAL									
	0	20	30	40	60	80	100	120	160	200
l/min	0	333	500	666	1000	1333	1666	2000	2666	3333

MODELO	DN Ø		P ₂		I (A)			CAUDAL										P.V.P.		A
	ASP.	IMP.	kW	Hp	1~230V	3~400V	0	20	30	40	60	80	100	120	160	200	MONOF.	TRIF.		
SCA65-40-125/2.2	65	40	2,2	3,0	14	4,9	33	27,5	22,5								1.492,00	1.835,00		
SCA65-40-125/3.0	65	40	3,0	4,0	-	6,3	40	34,5	28	19,5							-	1.968,00		
SCA65-50-125/4.0	65	50	4,0	5,5	-	9,6	28	25	22,5	20							-	2.220,00		
SCA65-50-160/5.5	65	50	5,5	7,5	-	11,1	35	33,5	31,5	29	20						-	2.253,00		
SCA80-65-125/7.5	80	65	7,5	10	-	14,9	34	33,8	33,5	32,5	30,5	27	22,5	15			-	2.483,00		
SCA80-65-125/9.2	80	65	9,2	12,5	-	18,3	36	35,5	35,2	34,5	33	31	28	23			-	2.670,00		
SCA100-80-160/11	100	80	11	15	-	21,2	30	29,8	29,5	29,2	28,5	27,5	26	24	19			-	3.007,00	
SCA100-80-160/15	100	80	15	20	-	28,6	38,5	38,2	38	37,8	37	36	34	31,5	26	18		-	3.205,00	

PREFILTROS INOX PARA BOMBAS DE PISCINA

DESCRIPCIÓN

- Prefiltros para bombas de grandes piscinas y embalses.
- Fabricados en **acero INOX 304**.



MODELO	DN ASP.	P.V.P.	A
PREFILTRO 1	2 1/2"	1.405,00	
PREFILTRO 2	3"	1.598,00	
PREFILTRO 3	4"	1.730,00	



BOMBAS CENTRÍFUGAS PISCINAS GRANDES DIMENSIONES SERIE CMP

DESCRIPCIÓN

- Electrobombas con prefiltro para recirculación y filtración de agua en grandes y medianas piscinas, piscinas públicas, atracciones acuáticas y similares.
- El prefiltro evita la entrada de sólidos a la hidráulica de la bomba, protegiendo el sistema de depuración de posibles atranques.
- Se suministran con contrabrida.



MATERIALES

- Cuerpo de bomba y pie: **Fundición**
- Eje: **Acero INOX 420**
- Impulsor: **Fundición**
- Soporte motor: **Fundición**
- Prefiltro: **Fundición**
- Malla: **Acero INOX 304 (prefiltro)**

ÁREA DE TRABAJO

- Temperatura máx. del líquido: **90°C**
- Grado de protección: **IP55**
- Aislamiento clase: **F**
- Servicio continuo



		CAUDAL									
m ³ /h	0	48	72	84	108	120	132	168	180	210	
l/min	0	800	1200	1400	1800	2000	2200	2800	3000	3500	

MODELO	DN Ø		P ₂		I (A)		MODELO	P.V.P. A
	ASP.	IMP.	kW	Hp	3~400V	BOMBA + FILTRO		
CMP 85/055	100	65	5,5	7,5	11,5		NM65-125/55 + FILTRO1	
CMP 85/075	100	65	7,5	10	15		NM65-125/75 + FILTRO1	
CMP 105/092	100	65	9,2	12,5	19		NM65-160/92 + FILTRO1	
CMP 110/110	100	65	11	15	21,8		NM65-160/110 + FILTRO1	
CMP 175/092	100	80	11	15	23,5		NM80-160/110 + FILTRO2	
CMP 150/150	100	80	15	20	29,4		NM80-160/150 + FILTRO2	
CMP 160/150	100	80	18,5	25	35,5		NM80-160/185 + FILTRO2	

		ALTIMETRO DE CARGA EN METROS										TRIF.
	23	21,3	19	17,5	13,7							
	27	26	24,5	23	20	18						1.667,00
	33	32	30	28	24	21,5						2.178,00
	36	35	33	31,5	28	25,5						2.365,00
	27	26,8	26,3	26,1	26	24,5	23	17,5	16			2.621,00
	32,8	32,1	31,9	31,8	31,3	30,2	29	23,7	22,1	16,7		2.947,00
	39	38	37,5	37,1	36,8	36,7	35,5	30	28,8	23,5		3.077,00

(* DN ASP. corresponde al DN del filtro. DN IMP. corresponde al DN de la bomba)

PREFILTROS PARA BOMBAS DE PISCINA

DESCRIPCIÓN

- Prefiltros para bombas de grandes piscinas y embalses, construidos en hierro fundido.
- Cestillo interior de **acero INOX 304**, tapa y cierre con palometas.
- Tamiz de diámetro 4 mm.



MODELO	DN ASP.	DN IMP.	P.V.P. A
FILTRO 1	4"	3"	620,00
FILTRO 2	4"	4"	689,00
FILTRO 3	5"	5"	795,00

* FILTRO 1 para bomba de 3" y conexión a 4"



CUADRO SERIE CPI

- Cuadro monofásico de construcción plástica, diseñado especialmente para el control y la protección de una bomba de filtración de piscinas o fuentes.
- Consta de selector de **3 modos de funcionamiento** para la bomba.
- Protección **IP55**
- Protección de bomba con disyuntor magnetotérmico.
- Programador electromecánico diario (fracciones de 30 min.)
- Interruptor neumático para bombas contracorriente.



MODELO	TENSIÓN	POTENCIA	REGULACIÓN	P.V.P. ^B
	Monof.	HP	A	
CPI0,5MF	1~230V	0,5	2,5 - 4,0	193,00
CPI1MF	1~230V	0,75 - 1,0	4,0 - 6,3	193,00
CPI1,5MF	1~230V	1,5 - 2,0	6,3 - 10,0	193,00

CUADRO SERIE CPI CON TRANSFORMADOR

- Cuadro monofásico de fabricación plástica, diseñado para el control y la protección de una bomba de filtración de piscina o fuente. Además, **incluye transformador** para el control de uno o varios focos de iluminación de hasta 300W.
- Selector de **3 modos de funcionamiento** para la bomba, y 2 posiciones para la iluminación.
- Protección **IP55**
- Protección de bomba con disyuntor magnetotérmico.
- Programador electromecánico diario (fracciones de 30 min.)



MODELO	TENSIÓN	POTENCIA	REGULACIÓN	P.V.P. ^B		
	Monof.	HP	A	50W	100W	300W
CPI0,5MTRILED	1~230V	0,5	2,5 - 4,0	234,00	255,00	320,00
CPI1MTRILED	1~230V	0,75 - 1,0	4,0 - 6,3	234,00	255,00	320,00
CPI1,5MTRILED	1~230V	1,5 - 2,0	6,3 - 10,0	234,00	255,00	320,00

CUADRO DE ILUMINACIÓN SERIE TR-P

- Cuadro diseñado exclusivamente para la iluminación de piscinas y fuentes que incorporen uno o varios proyectores de hasta 300W y 600W 12VAC.
- Se fabrica con tres o más transformadores en armario de poliéster con dos rejillas de ventilación, una de ellas con ventilador forzando la ventilación interna.



MODELO	TRAFOS	TENSIÓN		P.V.P. ^B
	CANTIDAD	ENTRADA	SALIDA	
TR1P-1	1	1~230V	12 VAC	332,00
TR2P-2	2	1~230V	12 VAC	460,00



Control de bomba



Control de la iluminación



HORIZONTALES
AUTOASPIRANTES
MULTICELULARES
BITURBINA



ELECTROBOMBA PERIFÉRICA SERIE PH

DESCRIPCIÓN

- Electrobomba periférica para tratamientos de agua, limpieza industrial, lavavajillas, rociadores de jardín, aire acondicionado, fertirrigación, etc.
- Ideal para presurización en caudales discretos.

MATERIALES

- Envoltente: **Fundición**
- Impulsor: **Latón**
- Cuerpo impulsión: **Fundición**
- Cuerpo aspiración: **Fundición**
- Eje: **Acero INOX 304**
- Acoplamiento motor: **Fundición**
- Cierre mecánico: **Alum/Graf**

ÁREA DE TRABAJO

- Temperatura máx. del líquido: **60°C**
- Agua limpia con partículas en suspensión
- Autoaspirante: **Hasta 5 m (con válvula de pie)**



BRASS CHANNEL



MODELO	DN Ø"	P ₂		I (A) 1~230V	COND. µF	PESO Kg	CAUDAL							P.V.P. B
		kW	Hp				0	0,6	0,9	1,2	1,5	1,8	2,1	
PH 50*	1	0,37	0,5	1,9	8	7,0	ALTURA DE CARGA EN METROS							MONOF. 89,00
							40	30	25	20	15	10	5	

MODELO	DN Ø"	P ₂		I (A) 1~230V	COND. µF	PESO Kg	CAUDAL						P.V.P. B
		kW	Hp				0,3	0,6	1,2	1,8	2,4	3	
PH 100*	1	0,75	1,0	4,5	20	9,5	ALTURA DE CARGA EN METROS						MONOF. 137,10
							61	56	48	39	31	18	

(*) Canal en latón (brass channel) en toda la serie PH para mayor durabilidad.

ELECTROBOMBAS CENTRÍFUGA AUTOASPIRANTE SERIE INOX

DESCRIPCIÓN

- Electrobomba en **acero INOX** para tratamientos de agua, limpieza industrial, lavavajillas, rociadores de jardín, aire acondicionado, etc.
- Ideal para presurización en caudales discretos.
- Uso para aguas limpias/potables.

MATERIALES

- Envoltente: **Acero INOX**
- Eje: **Acero INOX 304**
- Cuerpo impulsión: **Acero INOX**
- Cuerpo aspiración: **Acero INOX**
- Acoplamiento motor: **Fundición**
- Cierre mecánico: **Alum/Graf**

ÁREA DE TRABAJO

- Temperatura máx. del líquido: **35°C**
- Agua limpia con partículas en suspensión
- Líquidos no inflamables
- Autoaspirante: **Hasta 5 m con válvula de pie**



IMPULSOR INOX



MODELO	DN Ø"	P ₂		I (A) 1~230V	COND. µF	PESO Kg	CAUDAL							P.V.P. B
		kW	Hp				0,6	1,2	1,5	2	2,3	2,7	3	
INOX-100M	1	0,75	1,0	6,5	20	7,0	ALTURA DE CARGA EN METROS							MONOF. 186,50
							40	35	33	30	28	25	20	

ELECTROBOMBA CENTRÍFUGA AUTOASPIRANTE SERIE JET-C

DESCRIPCIÓN

- Electrobomba autoaspirante para pequeños suministros de agua, sistemas automáticos de rociadores de agua, pequeños sistemas de aire acondicionado o equipos auxiliares, etc.
- Uso con aguas limpias o líquidos no agresivos solamente, sin arenas ni otras impurezas sólidas.



MATERIALES

- Cuerpo de bomba: **Fundición**
- Eje: **Acero INOX 304**
- Soporte motor: **Fundición/Aluminio**
- Turbina: **Noryl**
- Acoplamiento motor: **Fundición**
- Acoplamiento motor: **PPO**
- Cierre mecánico: **Cer/Graf/NBR/AISI304**

ÁREA DE TRABAJO

- Temperatura máx. del líquido: **60°C**
- Grado de protección: **IP44**
- Aislamiento clase: **F**
- Presión máx. de servicio: **8 bar.**
- Agua limpia con partículas en suspensión



MODELO	DN		P ₂		I (A)		COND.	PESO	CAUDAL						P.V.P.	B
	Ø"	kw	Hp	1~230V	μF	Kg			m ³ /h							
JET 100C	1	0,75	1,0	4,3	20	7,0			ALTURA DE CARGA EN METROS						157,95	B
									10	20	30	35	40	50		

ELECTROBOMBA CENTRÍFUGA AUTOASPIRANTE SERIE JET-L

DESCRIPCIÓN

- Electrobombas autoaspirantes para el suministro de agua en pequeñas instalaciones domésticas, acopladas a tanques, para la transferencia de líquidos y el vaciado de grupos.
- Uso con aguas limpias o líquidos no agresivos solamente, sin arenas ni otras impurezas sólidas.



MATERIALES

- Cuerpo de bomba: **Fundición**
- Eje: **Acero INOX 304**
- Soporte motor: **Fundición/Aluminio**
- Turbina: **Bronce**
- Acoplamiento motor: **Fundición**
- Acoplamiento motor: **PPO**
- Cierre mecánico: **Cer/Graf/NBR/AISI304**

ÁREA DE TRABAJO

- Temperatura máx. del líquido: **60°C**
- Grado de protección: **IP44**
- Aislamiento clase: **F**
- Presión máx. de servicio: **8 bar.**
- Agua limpia con partículas en suspensión
- Servicio continuo



IMPULSOR BRONCE



MODELO	DN		P ₂		I (A)		COND.	PESO	CAUDAL								P.V.P.	B
	Ø"	kw	Hp	1~230V	3~400V	μF	Kg		m ³ /h									
JET 75L	1	0,55	0,75	3,2	-	16	16,0		ALTURA DE CARGA EN METROS								199,00	-
									0	10	20	30	40	50	60	70		
JET 100L	1	0,75	1,0	4,8	1,6	20	17,0		ALTURA DE CARGA EN METROS								208,00	208,00
									0	10	20	30	40	50	60	70		
JET 150L	1,5*1,25	1,1	1,5	8,5	-	40	32,0		ALTURA DE CARGA EN METROS								363,90	365,10
									0	10	20	30	40	50	60	70		

ELECTROBOMBA CENTRÍFUGA SERIE MP

DESCRIPCIÓN

- Electrobombas centrífugas ideales para suministro de agua doméstica, aspersores para jardín, riego, etc.

MATERIALES

- Envoltente: **Acero INOX**
- Eje: **Acero INOX 304**
- Impulsores: **Noryl**
- Difusores: **Noryl**
- Cuerpo aspiración: **Fundición**
- Cuerpo impulsión: **Fundición**
- Cierre mecánico: **Cer/Graf**

ÁREA DE TRABAJO

- Temperatura máx. del líquido: **35°C**
- Grado de protección: **IP44**
- Aislamiento clase: **B**
- Aguas limpias
- Líquidos no inflamables
- Autoaspirante: **Hasta 5 m con válvula de pie**



MUY SILENCIOSA



		CAUDAL										
m ³ /h		0	0,6	1,2	1,8	2,4	3	3,6	4,2	4,8	5,4	6,0
l/min		0	10	20	30	40	50	60	70	80	90	100

MODELO	DN		P ₂		I (A)		COND.		PESO	P.V.P. B
	Ø"		kW	Hp	1~230V	3~400V	µF	Kg		
MP80	1		0,55	0,75	3,7	16	11,4			
MP100	1		0,75	1,0	4,3	20	13,0			
MP120	1		0,9	1,2	7,0	20	14,0			

											ALTURA DE CARGA EN METROS				MONOF.	P.V.P. B
33	32	30,5	28,5	26	23	19,5	15,5	11								
																199,00
																209,00
																229,00

ELECTROBOMBA CENTRÍFUGA MULTICELULAR SERIE SBM

DESCRIPCIÓN

- Electrobombas para tratamientos de agua, limpieza industrial, rociadores de jardín, aire acondicionado, etc.
- Ideal para el abastecimiento y presurización de agua.

MATERIALES

- Envoltente: **Acero INOX 304**
- Eje: **Acero INOX 304**
- Impulsores: **Noryl**
- Difusores: **Noryl**
- Tomas impulsión: **Acero INOX 304**
- Tomas difusión: **Acero INOX 304**
- Acoplamiento motor: **Acero**
- Cierre mecánico: **Alum/Cer**

ÁREA DE TRABAJO

- Temperatura máx. del líquido: **35°C**
- Grado de protección: **IP54**
- Aislamiento clase: **B/F**
- Aguas limpias
- Líquidos no inflamables
- Autoaspirante: **Hasta 5 m con válvula de pie**
- Servicio continuo **S1**



MUY SILENCIOSA



		CAUDAL				
m ³ /h		0	1,2	2,4	3,6	4,8
l/min		0	20	40	60	80

MODELO	DN		P ₂		I (A)		PESO		P.V.P. B
	Ø"		kW	Hp	1~230V	3~400V	Kg		
SBM 203	1		0,55	0,75	3,5	1,0	12,0		
SBM 204	1		0,75	1,00	4,3	1,5	14,0		
SBM 205	1		1,1	1,50	7,6	2,0	16,0		

										ALTURA DE CARGA EN METROS				MONOF.	TRIF.	
38	33	25	15	5												
															294,90	292,60
															327,70	328,90
															362,30	358,10

		CAUDAL							
m ³ /h		0	1,2	2,4	3,6	4,8	6	7,2	8,4
l/min		0	20	40	60	80	100	120	140

MODELO	DN		P ₂		I (A)		PESO		P.V.P. B
	Ø"		kW	Hp	1~230V	3~400V	Kg		
SBM 403	1		0,75	1,00	6,7	1,5	12		
SBM 404	1		1,1	1,50	8,4	1,8	14		
SBM 405	1		1,5	2,00	11,0	2,2	16		

										ALTURA DE CARGA EN METROS				MONOF.	TRIF.	
35	34	33	30	25	20	14	6									
															308,70	310,30
															347,80	344,20
															450,80	402,10

ELECTROBOMBA CENTRÍFUGA MULTICELULAR SERIE HMP

DESCRIPCIÓN

- Electrobombas para trabajo con aguas limpias en aplicaciones domésticas, riego y conjuntos hidroneumáticos de presión.
- Su diseño las hace **completamente silenciosas**.



MUY SILENCIOSA

MATERIALES

- Camisa: **Acero INOX 304**
- Eje: **Acero INOX 420**
- Impulsores: **Acero INOX 304**
- Difusores: **Tecnopolímero**
- Cuerpo aspiración: **Fundición**
- Cuerpo impulsión: **Fundición**
- Cierre mecánico: **Grafito**
- Carcasa motor: **Aluminio L-2521**

ÁREA DE TRABAJO

- Temperatura máx. del líquido: **35°C**
- Grado de protección: **IP55**
- Aislamiento clase: **F**
- Servicio continuo **S1**



MODELO	DN	P ₂		I (A)			COND.			PESO	CAUDAL								P.V.P.	B									
		Ø"	kW	Hp	1~230V	µF	Kg	ALTURA DE CARGA EN METROS																					
																MONOF.	TRIF.												
HMP 15-3	1	0,37	0,5	2,7	12	9,0	0	0,6	1,2	1,8	2,4	3	3,6	0	10	20	30	40	50	60	30	29	27,5	25	21,5	17	10,7	248,00	-
HMP 15-4	1	0,55	0,75	3,5	14	9,8	0	1,2	1,8	2,4	3	3,6	4,2	0	15	30	45	60	75	90	40	37	34,5	31,5	27,5	23	14,5	281,00	-
HMP 15-5	1	0,75	1,0	4,1	20	10,6	0	1,8	2,4	3,0	3,6	4,2	4,8	0	20	40	60	80	100	120	50	48	44	39	32,5	24	18,5	301,00	-

MODELO	DN	P ₂		I (A)			COND.			PESO	CAUDAL										P.V.P.	B													
		Ø"	kW	Hp	1~230V	µF	Kg	ALTURA DE CARGA EN METROS																											
																		MONOF.	TRIF.																
HMP 25-4	1	0,92	1,25	6,1	25	14,0	0	0,9	1,8	2,7	3,6	4,5	5,4	6	7,2	0	15	30	45	60	75	90	100	120	43	42,5	41	38,5	37	35	30	26	10	343,00	-
HMP 25-5	1	1,1	1,5	7,4	25	17,0	0	1,2	1,8	2,4	3,0	3,6	4,2	4,8	5,4	0	20	40	60	80	100	120	140	166,7	53,5	53	51	48	45,5	43	37	32	20	385,00	-

MODELO	DN	P ₂		I (A)			COND.			PESO	CAUDAL												P.V.P.	B																																																																																																																																																																																																																																																																																																																																																																																																																																																																																																																																																																																																																																																																																																																																																																																																						
		Ø"	kW	Hp	1~230V	3~400V	µF	Kg	ALTURA DE CARGA EN METROS																																																																																																																																																																																																																																																																																																																																																																																																																																																																																																																																																																																																																																																																																																																																																																																																																					
																					MONOF.	TRIF.																																																																																																																																																																																																																																																																																																																																																																																																																																																																																																																																																																																																																																																																																																																																																																																																								
HMP 35-3	1 ¼	1,5	2,0	8,0	3,2	40	20,1	0	1,2	1,8	2,4	3,0	3,6	4,2	4,8	5,4	6	7,2	7,8	8,4	9	10	0	20	40	60	80	100	120	130	140	166,7	42	41,7	41	40	37	33	28	25	21	14	409,00	409,00																																																																																																																																																																																																																																																																																																																																																																																																																																																																																																																																																																																																																																																																																																																																																																																		
HMP 35-4	1 ¼	1,8	2,5	10,1	4,0	40	21,4	0	1,5	2,1	2,7	3,3	3,9	4,5	5,1	5,7	6,3	6,9	7,5	8,1	8,7	9,3	0	25	50	75	100	125	150	175	200	225	56	55,7	50	53	50	45	39	35	30	19,8	470,00	470,00																																																																																																																																																																																																																																																																																																																																																																																																																																																																																																																																																																																																																																																																																																																																																																																		
HMP 35-5	1 ¼	2,2	3,0	13,1	4,8	50	22,6	0	1,8	2,4	3,0	3,6	4,2	4,8	5,4	6,0	6,6	7,2	7,8	8,4	9,0	0	30	60	90	120	150	180	210	240	270	300	330	360	390	420	450	480	510	540	570	600	630	660	690	720	750	780	810	840	870	900	930	960	990	1020	1050	1080	1110	1140	1170	1200	1230	1260	1290	1320	1350	1380	1410	1440	1470	1500	1530	1560	1590	1620	1650	1680	1710	1740	1770	1800	1830	1860	1890	1920	1950	1980	2010	2040	2070	2100	2130	2160	2190	2220	2250	2280	2310	2340	2370	2400	2430	2460	2490	2520	2550	2580	2610	2640	2670	2700	2730	2760	2790	2820	2850	2880	2910	2940	2970	3000	3030	3060	3090	3120	3150	3180	3210	3240	3270	3300	3330	3360	3390	3420	3450	3480	3510	3540	3570	3600	3630	3660	3690	3720	3750	3780	3810	3840	3870	3900	3930	3960	3990	4020	4050	4080	4110	4140	4170	4200	4230	4260	4290	4320	4350	4380	4410	4440	4470	4500	4530	4560	4590	4620	4650	4680	4710	4740	4770	4800	4830	4860	4890	4920	4950	4980	5010	5040	5070	5100	5130	5160	5190	5220	5250	5280	5310	5340	5370	5400	5430	5460	5490	5520	5550	5580	5610	5640	5670	5700	5730	5760	5790	5820	5850	5880	5910	5940	5970	6000	6030	6060	6090	6120	6150	6180	6210	6240	6270	6300	6330	6360	6390	6420	6450	6480	6510	6540	6570	6600	6630	6660	6690	6720	6750	6780	6810	6840	6870	6900	6930	6960	6990	7020	7050	7080	7110	7140	7170	7200	7230	7260	7290	7320	7350	7380	7410	7440	7470	7500	7530	7560	7590	7620	7650	7680	7710	7740	7770	7800	7830	7860	7890	7920	7950	7980	8010	8040	8070	8100	8130	8160	8190	8220	8250	8280	8310	8340	8370	8400	8430	8460	8490	8520	8550	8580	8610	8640	8670	8700	8730	8760	8790	8820	8850	8880	8910	8940	8970	9000	9030	9060	9090	9120	9150	9180	9210	9240	9270	9300	9330	9360	9390	9420	9450	9480	9510	9540	9570	9600	9630	9660	9690	9720	9750	9780	9810	9840	9870	9900	9930	9960	9990	10020	10050	10080	10110	10140	10170	10200	10230	10260	10290	10320	10350	10380	10410	10440	10470	10500	10530	10560	10590	10620	10650	10680	10710	10740	10770	10800	10830	10860	10890	10920	10950	10980	11010	11040	11070	11100	11130	11160	11190	11220	11250	11280	11310	11340	11370	11400	11430	11460	11490	11520	11550	11580	11610	11640	11670	11700	11730	11760	11790	11820	11850	11880	11910	11940	11970	12000	12030	12060	12090	12120	12150	12180	12210	12240	12270	12300	12330	12360	12390	12420	12450	12480	12510	12540	12570	12600	12630	12660	12690	12720	12750	12780	12810	12840	12870	12900	12930	12960	12990	13020	13050	13080	13110	13140	13170	13200	13230	13260	13290	13320	13350	13380	13410	13440	13470	13500	13530	13560	13590	13620	13650	13680	13710	13740	13770	13800	13830	13860	13890	13920	13950	13980	14010	14040	14070	14100	14130	14160	14190	14220	14250	14280	14310	14340	14370	14400	14430	14460	14490	14520	14550	14580	14610	14640	14670	14700	14730	14760	14790	14820	14850	14880	14910	14940	14970	15000	15030	15060	15090	15120	15150	15180	15210	15240	15270	15300	15330	15360	15390	15420	15450	15480	15510	15540	15570	15600	15630	15660	15690	15720	15750	15780	15810	15840	15870	15900	15930	15960	15990	16020	16050	16080	16110	16140	16170	16200	16230	16260	16290	16320	16350	16380	16410	16440	16470	16500	16530	16560	16590	16620	16650	16680	16710	16740	16770	16800	16830	16860	16890	16920	16950	16980	17010	17040	17070	17100	17130	17160	17190	17220	17250	17280	17310	17340	17370	17400	17430	17460	17490	17520	17550	17580	17610	17640	17670	17700	17730	17760	17790	17820	17850	17880	17910	17940	17970	18000	18030	18060	18090	18120	18150	18180	18210	18240	18270	18300	18330	18360	18390	18420	18450	18480	18510	18540	18570	18600	18630	18660	18690	18720	18750	18780	18810	18840	18870	18900	18930	18960	18990	19020	19050	19080	19110	19140	19170	19200	19230	19260	19290	19320	19350	19380	19410	19440	19470	19500	19530	19560	19590	19620	19650	19680	19710	19740	19770	19800	19830	19860	19890	19920	19950	19980	20010	20040	20070	20100	20130	20160	20190	20220	20250	20280	20310	20340	20370	20400	20430	20460	20490	20520	20550	20580	20610	20640	20670	20700	20730	20760	20790	20820	20850	20880	20910	20940	20970	21000	21030	21060	21090	21120	21150	21180	21210	21240	21270	21300	21330	21360	21390	21420	21450	21480	21510	21540	21570	21600	21630	21660	21690	21720	21750	21780	21810	21840	21870	21900	21930	21960	21990	22020	22050	22080	22110	22140	22170	22200	22230	22260	22290	22320	22350	22380	22410	22440	22470	22500	22530	22560	22590	22620	22650	22680	22710	22740	22770	22800	22830	22860	22890	22920	22950	22980	23010	23040	23070	23100	23130	23160	23190	23220	23250	23280

ELECTROBOMBA CENTRÍFUGA MULTICELULAR SERIE SH

DESCRIPCIÓN

- Electrobombas multicelulares diseñadas para sistemas de aire acondicionado, refrigeración, actividades industriales de limpieza, transporte y circulación de líquidos, así como suministro de agua doméstica, aspersores de jardín, etc.



MATERIALES

- Eje: **Acero INOX 304**
- Cuerpo aspiración: **Acero INOX 304**
- Cuerpo impulsión: **Acero INOX 304**
- Soporte bomba: **Fundición acero**
- Cierre mecánico: **Alum/Cer EPD**

ÁREA DE TRABAJO

- Temperatura máx. del líquido: **70°C**
- Grado de protección: **IP55**
- Aislamiento clase: **F**
- Aguas limpias con partículas en suspensión
- Líquidos no inflamables
- Presión máx.: **1.0 Mpa**
- Servicio continuo **S1**



MUY SILENCIOSA



MODELO	DN (Ø")		P ₂		PESO		CAUDAL							P.V.P.							
	ASP.	IMP.	kW	Hp	Kg	ALTURA DE CARGA EN METROS							MONOF.	TRIF.							
								0	1	1,5	2	2,5	3	3,5							
SH 2-40	1	1	0,55	0,75	9	0	1	1,5	2	2,5	3	3,5	38	35	32	28	26	23	17	300,00	301,00
SH 2-50	1	1	0,55	0,75	10	0	17	25	33	42	50	58	47,5	43	40	35	33	28	22	342,00	323,00
SH 2-60	1	1	0,75	1,0	11	0	17	25	33	42	50	58	56	50	48	42	38	32	25	355,00	372,00

MODELO	DN (Ø")		P ₂		PESO		CAUDAL							P.V.P.							
	ASP.	IMP.	kW	Hp	Kg	ALTURA DE CARGA EN METROS							MONOF.	TRIF.							
								0	2	3	4	5	6	7 <th></th> <th></th>							
SH 4-40	1 ¼	1	0,75	1,0	11	0	33	50	67	83	100	117	39,8	37	36	34	30	26	20	332,00	335,00
SH 4-50	1 ¼	1	1,0	1,35	12	0	33	50	67	83	100	117	49	45	44	40	36	31	24	364,00	366,00
SH 4-60	1 ¼	1	1,1	1,5	13	0	33	50	67	83	100	117	59	55	53	50	45	38	30	413,00	392,00

MODELO	DN (Ø")		P ₂		PESO		CAUDAL										P.V.P.									
	ASP.	IMP.	kW	Hp	Kg	ALTURA DE CARGA EN METROS										MONOF.	TRIF.									
								0	4	5	6	7	8	9	10 <th colspan="10"></th> <th></th> <th></th>											
SH 8-20	1 ½	1 ½	1,0	1,35	18	0	67	83	100	117	133	150	167	34,8	32	29	27	25	24	21	17	394,00	387,00			
SH 8-25	1 ½	1 ½	1,5	2,0	20	0	67	83	100	117	133	150	167	49,8	43	40	38	34	27	25	20	509,00	460,00			
SH 8-30	1 ½	1 ½	1,85	2,5	25	0	67	83	100	117	133	150	167	56	50	46	44	40	36	30	26	642,00	490,00			
SH 8-35	1 ½	1 ½	2,2	3,0	26	0	67	83	100	117	133	150	167	62	56	51	48	44	43	35	28	676,00	527,00			
SH 8-40	1 ½	1 ½	2,2	3,0	28	0	67	83	100	117	133	150	167	68,8	65	57,5	57	50	48	42	34	686,00	530,00			

MODELO	DN (Ø")		P ₂		PESO		CAUDAL											P.V.P.											
	ASP.	IMP.	kW	Hp	Kg	ALTURA DE CARGA EN METROS											MONOF.	TRIF.											
								0	6	7	8	9	10	11	12	13	14 <th colspan="11"></th> <th></th> <th></th>												
SH 12-20	1 ½	1 ½	1,85	2,5	24	0	100	117	133	150	167	183	200	217	233	40	38	36	35	32	31	29	28	24	20	605,00	457,00		
SH 12-25	1 ½	1 ½	2,2	3,0	26	0	100	117	133	150	167	183	200	217	233	50	47	45	43	41,5	39	36	33,5	30,5	27	636,00	486,00		
SH 12-30	1 ½	1 ½	3,0	4,0	28	0	100	117	133	150	167	183	200	217	233	60	53,5	52	50	47,5	45	42	39	35	30	-	622,00		

ELECTROBOMBA CENTRÍFUGA MULTICELULAR SERIE SH

MODELO	DN (Ø")		P ₂		PESO	CAUDAL										P.V.P.												
	ASP.	IMP.	kW	Hp		Kg	ALTURA DE CARGA EN METROS										MONOF.	TRIF.										
SH 16-30	2	2	2,2	3,0	26	m ³ /h	0	8	10	12	14	16	18	20	22	24	40	38	36	34	33	30	28	26	23	20	670,00	567,00
SH 16-40	2	2	3,0	4,0	29	l/min	0	133	167	200	233	267	300	333	367	400	53	50	48	46	44	43	38	36	32	28	-	713,00

MODELO	DN (Ø")		P ₂		PESO	CAUDAL										P.V.P.														
	ASP.	IMP.	kW	Hp		Kg	ALTURA DE CARGA EN METROS										MONOF.	TRIF.												
SH 20-30	2	2	3,0	4,0	29	m ³ /h	0	10	12	14	16	18	20	22	24	26	28	40	39	38	36	35	33	31,5	30	27	24	21	-	633,00
SH 20-40	2	2	4,0	5,5	34	l/min	0	167	200	233	267	300	333	367	400	433	467	52	50	48	46	44	42	40	36	32	28	24	-	863,00

SAQUE EL MÁXIMO PODER A SU BOMBA CON NUESTROS CONTROLADORES DE PRESIÓN

Descubra nuestra gama completa de controladores en la pág. 206



ELECTROBOMBA CENTRÍFUGA HORIZONTAL SERIE ULTRA

DESCRIPCIÓN

- Electrobombas centrífugas multicelulares horizontales para garantizar presiones elevadas.
- Particularmente apropiadas para aplicaciones civiles e industriales, en particular equipos de presión, instalaciones de contraincendios e instalaciones de lavado.



ULTRA-3



ULTRA-7



ULTRA-18

CARACTERÍSTICAS CONSTRUCTIVAS

- | | |
|---------------------------|--|
| • Cuerpo de bomba | Acero INOX 304 |
| • Soporte del motor | Fundición |
| • Impulsor | Noryl® |
| • Sello mecánico | Cerámica/Grafito (6 impulsores)
Grafito/Carb. de silicio (7 impulsores) |
| • Eje del motor | Acero INOX 303 |
| • Temperatura del líquido | De -5° a 35°C |
| • Presión de trabajo | Máximo 8,5 bar |

CARACTERÍSTICAS DEL MOTOR

- | | |
|-----------------------------|--|
| • Motor 2 polos a inducción | 3~ 230/400V-50 Hz
1~ 230V-50 Hz |
| • Clase de aislamiento | F |
| • Grado de protección | IPX4 |

DN Ø" (ASPIRACIÓN - IMPULSIÓN)

- | | |
|-------------|------------------|
| • Serie U3 | 1 - 1 |
| • Serie U5 | 1 - 1 |
| • Serie U7 | 1 ¼ - 1 |
| • Serie U9 | 1 ½ - 1 ¼ |
| • Serie U18 | 2 - 1 ½ |



DIFUSOR



IMPULSOR

- Conjunto hidráulico fabricado en **Noryl**
- Opcionalmente se suministra en **INOX**

ELECTROBOMBA CENTRÍFUGA HORIZONTAL SERIE ULTRA

MODELO	P ₂		I (A)		PESO Kg	CAUDAL								P.V.P.	A						
	kW	Hp	1~230V	3~400V		ALTURA DE CARGA EN METROS															
						MONOF.	TRIF.														
U3-90/4	0,66	0,9	4,0	1,8	8,5	0	0,6	1,2	1,8	2,4	3,6	4,8	40,8	38,3	35,1	31,8	27,9	19,8	10,4	385,00	385,00
U3-100/5	0,75	1,0	4,8	1,9	10,5	0	10	20	30	40	60	80	52,2	48,9	45,1	40,8	36	25,4	14	435,00	435,00
U3-120/6	0,9	1,2	5,6	2,6	11,5	0	10	20	30	40	60	80	62,8	58,7	54,5	49,6	43,9	32,1	18,3	483,00	483,00
U3-150/7	1,1	1,5	6,1	3	14,5	0	10	20	30	40	60	80	77,1	76,1	73,2	68,4	62,3	46,5	25,7	624,00	608,00

MODELO	P ₂		I (A)		PESO Kg	CAUDAL								P.V.P.	A								
	kW	Hp	1~230V	3~400V		ALTURA DE CARGA EN METROS																	
						MONOF.	TRIF.																
U5-120/4	0,9	1,2	5,2	2,5	11,0	0	1,8	2,4	3,6	4,8	6	7,2	8,4	45,3	41,3	39,6	35,6	30,8	24,9	17,6	6,4	440,00	440,00
U5-150/5	1,1	1,5	6,6	3,1	17,5	0	30	40	60	80	100	120	140	57,6	55,6	54,2	50,5	45	37	27,4		624,00	608,00
U5-180/6	1,3	1,8	7,4	3,3	17,5	0	30	40	60	80	100	120	140	69,1	66,5	64,8	60,1	53,2	43,8	32		668,00	641,00
U5-200/7	1,5	2,0	8,6	3,6	17,0	0	30	40	60	80	100	120	140	80,6	77,1	75,1	69,6	61,3	50,4	35,8		749,00	722,00

MODELO	P ₂		I (A)		PESO Kg	CAUDAL								P.V.P.	A							
	kW	Hp	1~230V	3~400V		ALTURA DE CARGA EN METROS																
						MONOF.	TRIF.															
U7-180/4	1,3	1,8	7,9	3,3	16,0	0	2,4	3,6	4,8	6	7,2	8,4	49,6	48,4	46,7	43,8	39,9	34,9	28,9		612,00	582,00
U7-250/5	1,85	2,5	9,9	4,0	17,5	0	40	60	80	100	120	140	63,2	62,1	60,3	56,9	52,1	46,2	39		671,00	636,00
U7-300/6	2,2	3,0	11,5	4,7	18,0	0	40	60	80	100	120	140	76	75,1	73,1	69,2	63,6	56,8	48,2		981,00	685,00
U7-350/7	2,6	3,5	-	5,1	22,0	0	40	60	80	100	120	140	89	88	85,8	81,2	74,5	66,3	56,2		-	945,00

MODELO	P ₂		I (A)		PESO Kg	CAUDAL								P.V.P.	A							
	kW	Hp	1~230V	3~400V		ALTURA DE CARGA EN METROS																
						MONOF.	TRIF.															
U9-200/4	1,5	2,0	8,3	3,5	17,5	0	3,6	6	8,4	9,6	12	13,2	45,8	42,1	40,7	37,3	31,3	23	17,9		655,00	627,00
U9-250/5	1,85	2,5	10,4	4,1	16,5	0	60	100	140	160	200	220	56,9	52,2	50,4	46,1	38,8	28,2	22,3		711,00	673,00

MODELO	P ₂		I (A)		PESO Kg	CAUDAL								P.V.P.	A									
	kW	Hp	3~400V	Kg		ALTURA DE CARGA EN METROS																		
						TRIF.																		
U18-250/3	1,85	2,5	4,2	16,0	0	6	7,2	9,6	12	14,4	16,8	19,2	21,6	34,7	32,9	32,6	31,6	30,1	28	24,7	20,6	15,9	10,7	658,00
U18-400/4	3,0	4,0	5,8	24,0	0	100	120	160	200	240	280	320	360	47,1	45,4	45,2	44,3	42,6	40	36	30,6	24,6	17,8	1.021,00



ELECTROBOMBA CENTRÍFUGA BITURBINA SERIE CB

DESCRIPCIÓN

- Electrobombas con doble turbina aptas para realizar unidades de presurización para instalaciones civiles e industriales.
- Las dos turbinas contrapuestas garantizan una elevada altura con un buen caudal.

MATERIALES

- Envolvente: **Fundición**
- Eje: **Acero INOX 303**
- Impulsor: **Noryl (CB 100 a CB 900)**
- Tomas aspiración: **Fundición**
- Tomas impulsión: **Fundición**
- Acoplamiento motor: **Fundición acero**
- Cierre mecánico: **Cer/Graf/NRB**

ÁREA DE TRABAJO

- Temperatura máx. del líquido: **50°C (Noryl)**
- Grado de protección: **IPX4/IPX5 (CB 900)**
- Aislamiento clase: **F**
- Servicio continuo



		CAUDAL									P.V.P.						
		m³/h	0	1,2	2,4	3,6	4,8	7,2	8,4	9	A						
		l/min	0	20	40	60	80	120	140	150							
MODELO	DN (Ø")	P ₂	I (A)		PESO		ALTURA DE CARGA EN METROS						MONOF.	TRIF.			
	ASP.	IMP.	kW	Hp	1~230V	3~400V	Kg										
CB 100	1	1	0,75	1,0	5,4	2,4	15,5	42	39,4	34,7	29,2	21	432,00	432,00			
CB 160	1 ¼	1	1,1	1,5	8,5	3,7	26,5	48,3	47,1	45,7	43,5	40,1	31,1	595,00	573,00		
CB 210	1 ¼	1	1,5	2,0	10,4	4,4	27	54,9	53,8	52,3	50,5	47,1	38,3	32,4	662,00	635,00	
CB 310	1 ¼	1	2,2	3,0	-	5,2	35,5	61,4	60,3	59,2	57,1	53,6	44,2	38,3	35,2	-	644,00

		CAUDAL										P.V.P.					
		m³/h	0	1,5	4,5	7,5	9	10,5	12	13,5	15	16,5	A				
		l/min	0	25	75	125	150	175	200	225	250	275					
MODELO	DN (Ø")	P ₂	I (A)		PESO		ALTURA DE CARGA EN METROS						TRIF.				
	ASP.	IMP.	kW	Hp	3~400V	Kg											
CB 400	1 ½	1 ¼	3,0	4,0	6,7	48	63,6	63,1	60,3	55,5	52,3	48,4	43,9	1.284,00			
CB 600	1 ½	1 ¼	4,0	5,5	9,1	56,5	76,9	76,4	73,8	69	65,9	62,1	58	53,4	1.340,00		
CB 750	1 ½	1 ¼	5,5	7,5	11,5	56	90,7	90	87,3	82,9	80,1	76,8	73,1	68,8	63,7	1.649,00	
CB 900	1 ½	1 ¼	6,6	9,0	13,3	62	97,5	96,6	93,7	89,2	86,5	83,3	79,8	75,2	71,2	66,4	1.739,00

ELECTROBOMBA CENTRÍFUGA BITURBINA SERIE CBP

DESCRIPCIÓN

- Electrobombas con dos impulsores opuestos que permiten elevaciones más altas.
- Cualificadas para el equipamiento civil e industrial, distribución de agua por grupos de presión y para el riego en jardinería y agricultura.

MATERIALES

- Cuerpo bomba: **Fundición**
- Eje: **AISI 1045**
- Impulsor: **Latón/Fundición***
- Cierre mecánico: **NBR/Graf/Cer**

ÁREA DE TRABAJO

- Temperatura máx. del líquido: **90°C**
- Grado de protección: **IP44**
- Aislamiento clase: **B**
- Servicio continuo



		CAUDAL										P.V.P.				
		m³/h	0	4,5	9,3	13	15,7	17,6	19	30	34,2	B				
		l/min	0	75	155	216	261	293	316	500	570					
MODELO	DN (Ø")	P ₂	I (A)		PESO		ALTURA DE CARGA EN METROS						TRIF.			
	ASP.	IMP.	kW	Hp	3~400V	Kg										
CBP 400	1 ½	1 ¼	3,0	4,0	8,0		66	61,5	51,7	41,3	24,7		747,90			
CBP 550	1 ½	1 ¼	4,0	5,5	9,7		77	73	62,2	54,2	49,3	35,3	24,2	848,90		
CBP 750	1 ½	1 ¼	5,5	7,5	12,0		89,5	83,5	73	63,3	55,2	43		1.142,00		
CBP 1500	2	1 ½	11,0	14,6	24,5		100	97	94	89,1	85,5	83,2	81	58,5	43,9	1.702,00

(*) Modelos hasta 5,5 con impulsor en latón. Modelo de 11,0 kW impulsor en fundición.

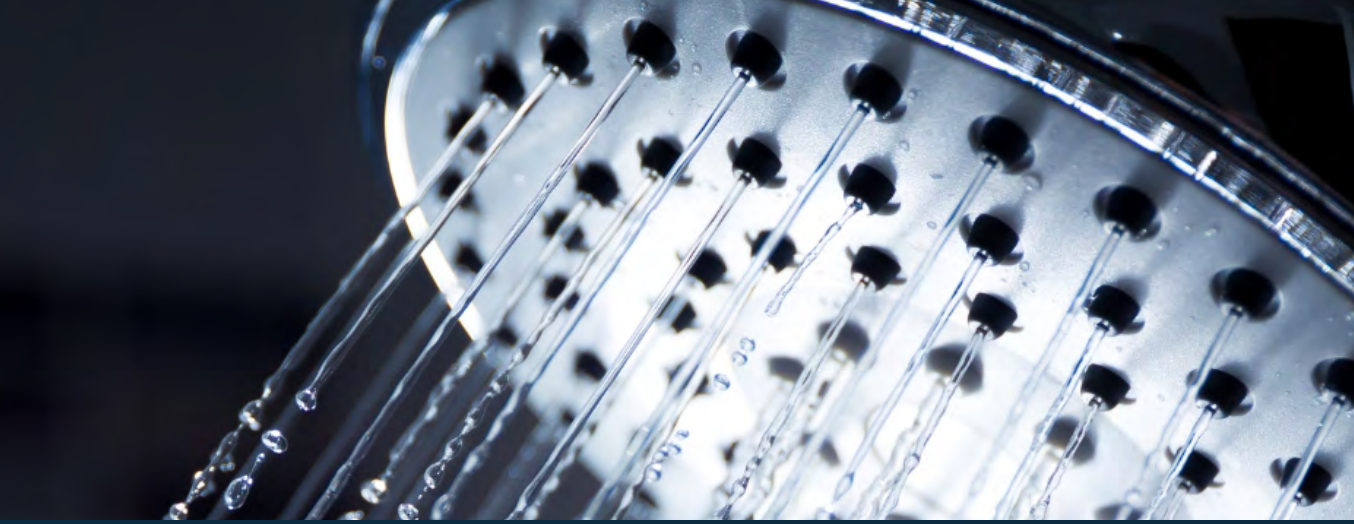

VERTICALES MULTICELULARES

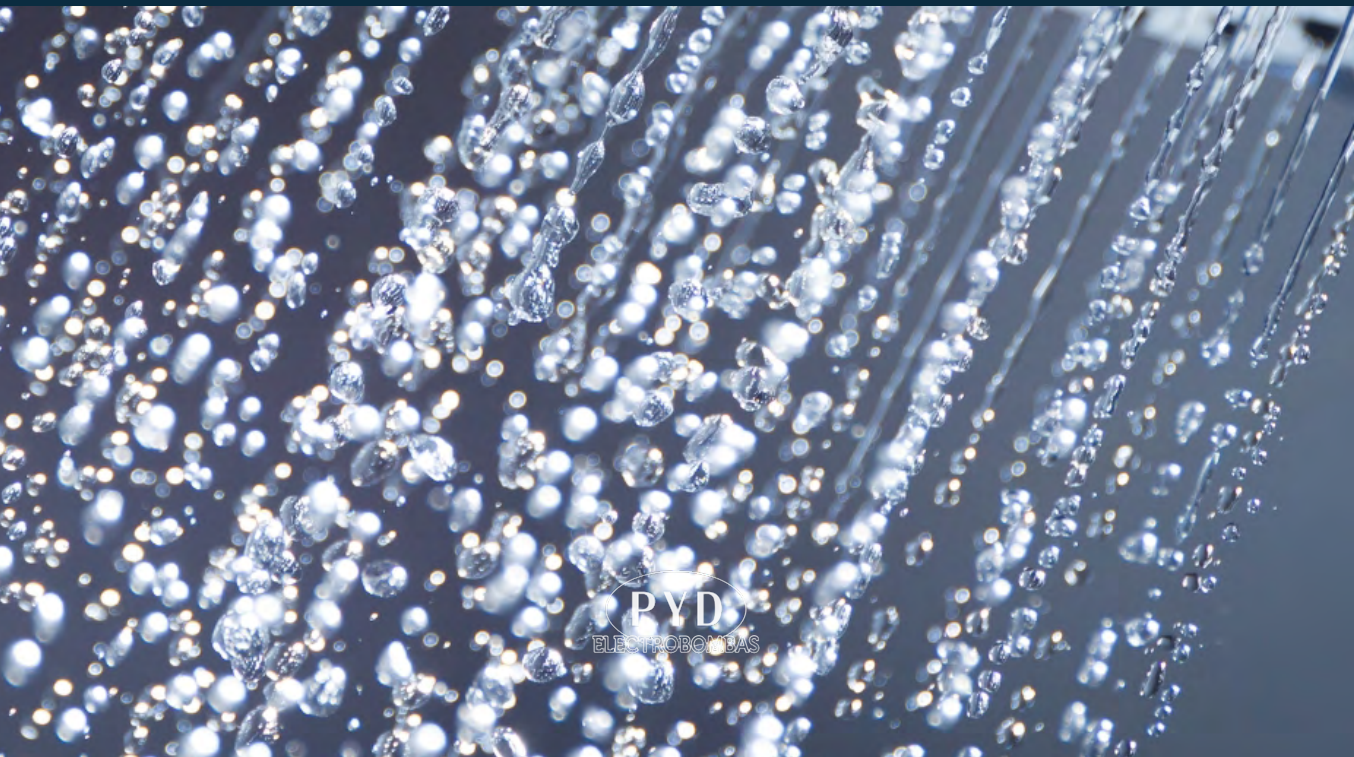

ELECTROBOMBA MULTICELULAR VERTICAL SERIE ULTRA

DESCRIPCIÓN

- Electrobombas centrífugas multicelulares verticales que garantizan presiones elevadas.
- Particularmente apropiadas para aplicaciones civiles e industriales, en particular equipos de presión, instalaciones contra incendios e instalaciones de lavado.

CARACTERÍSTICAS CONSTRUCTIVAS

- Cuerpo de bomba **Acero INOX 304**
- Soporte del motor **Fundición**
- Impulsor **Noryl**
- Sello mecánico **Cerámica/grafito**
- Eje del motor **Acero AISI 303**
- Temperatura del líquido **De 5° a 35°C**
- Presión de trabajo **8 bar (≤6 impulsores)
14 bar (≥7 impulsores)**

CARACTERÍSTICAS DEL MOTOR

- Motor 2 polos a inducción **3~ 230/400V-50 Hz
1~ 230V-50 Hz**
- Clase de aislamiento **F**
- Grado de protección **IPX4
IPX5 (>4,5HP)**

DN Ø" (ASPIRACIÓN - IMPULSIÓN)

- Serie U5V **1 1/4 - 1 1/4**
- Serie U7V **1 1/4 - 1 1/4**
- Serie U9V **1 1/2 - 1 1/4**
- Serie U18V **2 - 1 1/2**



MODELO	P ₂		I (A)		PESO Kg	CAUDAL								P.V.P.		
	kW	Hp	1~230V	3~400V		m ³ /h	0	1,8	2,4	3,6	4,8	6	7,2	8,4	MONOF.	TRIF.
U5V-150/5	1,1	1,5	6,8	2,8	20,7	56,8	53	51	46,1	40,1	33,3	24,8	11,5	742,00	728,00	
U5V-180/6	1,3	1,8	7,7	3,0	21,6	69,3	64,4	62	55,6	48,2	39,6	28,8	12	781,00	750,00	
U5V-200/7	1,5	2,0	9,0	3,4	23,4	80,3	73,6	71	64,5	56,1	46	33,4	12,5	848,00	819,00	
U5V-250/8	1,85	2,5	10,7	4,1	24,0	91,4	85	81,8	74,3	65,5	54,7	40,4	19,1	895,00	858,00	
U5V-280/9	2,1	2,8	11,7	4,4	26,3	102,1	94,6	90,7	81,6	71	58,5	42,3	20,1	1.071,00	879,00	
U5V-300/10	2,2	3,0	12,8	4,9	26,7	112,7	103,9	99,9	89,8	78,2	64	46,4	21	1.155,00	918,00	
U5V-350/11	2,6	3,5	13,3	5,0	29,7	122	111,2	106,3	95,6	83,1	67,6	48,2	22	1.226,00	1.130,00	
U5V-380/12	2,85	3,8	-	6,0	32,3	138,4	127,2	122,4	111,7	97,3	80,4	58,8	28,9	-	1.217,00	

MODELO	P ₂		I (A)		PESO Kg	CAUDAL								P.V.P.		
	kW	Hp	1~230V	3~400V		m ³ /h	0	2,4	3,6	4,8	6	7,2	8,4	9,6	MONOF.	TRIF.
U7V-180/4	1,3	1,8	8,3	3,2	21,0	49,5	47,4	45,3	42,5	39,2	34,8	29,4	22,6	735,00	710,00	
U7V-250/5	1,85	2,5	10,9	4,2	23,0	62,6	60,6	58,2	55,1	51,1	45,8	39	29,8	787,00	750,00	
U7V-300/6	2,2	3,0	12,2	5,0	25,5	74,8	71,5	68,3	64,5	59,3	53	44,6	34,5	1.088,00	790,00	
U7V-350/7	2,6	3,5	-	5,5	25,9	87,2	83,3	79,3	74,6	68,9	61,9	52,5	41	-	1.016,00	
U7V-400/8	3,0	4,0	-	6,8	28,8	99,5	96,1	92,6	87,9	81,9	74,6	64,4	51	-	1.110,00	
U7V-450/9	3,3	4,5	-	7,0	33,3	113,2	109,7	105,4	100,1	93,5	84,8	73,6	59,6	-	1.421,00	
U7V-550/10	4,0	5,5	-	8,3	36,3	127	123,8	119,6	114,1	106,6	97,6	86,0	70,3	-	1.547,00	

MODELO	P ₂		I (A)		PESO Kg	CAUDAL								P.V.P.		
	kW	Hp	1~230V	3~400V		m ³ /h	0	3,6	6	8,4	9,6	12	13,2	14,4	MONOF.	TRIF.
U9V-200/4	1,5	2,0	8,4	3,3	22,6	47,1	43,5	40,5	35,7	32,4	23,8	18,9	13,3	760,00	734,00	
U9V-250/5	1,85	2,5	10,6	4,3	23,2	59,2	54,4	50,4	44,8	40,5	29,8	23,5	16,3	804,00	767,00	
U9V-300/6	2,2	3,0	12,2	4,8	25,9	69,4	63,7	58,8	51,6	46,5	33,5	25,4	17	1.096,00	853,00	
U9V-400/7	3,0	4,0	-	5,7	28,8	82	76	70,9	63	57	41	31,2	20,1	-	1.123,00	
U9V-450/8	3,3	4,5	-	6,4	33,2	94,5	88,4	83	74,7	68	49,8	38,9	27	-	1.431,00	
U9V-500/9	3,7	5,0	-	6,9	33,7	105,4	98,9	92,7	82,8	75	54,5	41,8	28	-	1.478,00	
U9V-550/10	4,0	5,5	-	8,3	36,7	117,6	111	105,3	95,1	87,2	64,8	51,2	36,4	-	1.592,00	

MODELO	P ₂		I (A)		PESO Kg	CAUDAL								P.V.P.		
	kW	Hp	3~400V	Kg		m ³ /h	0	6	12	14,4	16,8	19,2	22,8	24	MONOF.	TRIF.
U18V-400/4	3,0	4,0	5,5	29,2	46,8	44,2	40,1	36,9	32,6	27,4	18,4	15,2	-	1.065,00		
U18V-450/5	3,3	4,50	6,6	33,9	59,1	55,9	49,7	45,5	40,3	34,3	23,9	19,8	-	1.326,00		
U18V-550/6	4,0	5,5	8,7	37,1	71,6	68,2	61,9	57	51,1	43,7	29,9	25,2	-	1.429,00		
U18V-750/8	5,5	7,5	10,7	50,4	96,1	92,6	84,4	78,3	69,8	59,1	40,5	34,3	-	2.047,00		
U18V-900/9	6,6	9,0	12,8	55,3	108	103,6	94,1	87,5	78,3	66,2	45,5	38,3	-	2.216,00		

ELECTROBOMBA CENTRÍFUGA VERTICAL SERIE VERTI-P



DESCRIPCIÓN

- Electrobombas centrífugas multietapa en ejecución vertical, diseñadas para la presurización de viviendas, sistemas de riego y aplicaciones de bombeo de agua limpia donde se requiera una bomba robusta y compacta.
- Cuerpos de aspiración e impulsión orientables y suministrados con **contrabrida ovalada DIN 2558**.

MATERIALES

- Camisa: **Acero INOX**
- Eje: **Acero INOX 304**
- Impulsores: **Polipropileno**
- Difusores: **Polipropileno**
- Cierre mecánico: **Cer/Graf**
- Cuerpo aspiración: **Fundición**
- Cuerpo impulsión: **Fundición**

ÁREA DE TRABAJO

- Temperatura máx. del líquido: **60°C**
- Grado de protección: **IP55**
- Aislamiento clase: **F**
- Servicio continuo **S1**



MULTICELULARES VERTICAL

MODELO	DN (Ø")		P ₂		I (A)			PESO	CAUDAL					P.V.P.		
	ASP.	IMP.	kW	Hp	1~230V	3~400V	Kg		m ³ /h	0	1	2	3	4	MONOF.	TRIF.
									l/min	0	16,6	33,3	50	66,6		
									ALTURA DE CARGA EN METROS							
VERTI 254P	1	1	0,75	1,0	4,5	2,0	16,5	48	45	35	26	11	334,20	333,10		
VERTI 255P	1	1	1,1	1,5	5,0	2,5	17,9	59	57	44	33	15	355,10	358,00		
VERTI 256P	1	1	1,1	1,5	6,0	2,5	18,2	69	65	52	37	18	363,00	366,00		
VERTI 257P	1	1	1,1	1,5	7,0	3,0	22,3	82	75	62	45	25	423,80	410,30		
VERTI 258P	1	1	1,5	2,0	7,5	3,5	23,8	94	87	72	52	28	446,70	441,70		
VERTI 259P	1	1	1,5	2,0	8,5	3,5	24,1	105	98	82	60	35	455,20	449,70		
VERTI 2511P	1	1	1,8	2,5	10,0	4,5	25,2	130	119	98	69	37	581,00	548,00		
VERTI 2513P	1	1	2,2	3,0	-	4,5	26,2	153	142	115	80	39	-	565,20		

MODELO	DN (Ø")		P ₂		I (A)			PESO	CAUDAL							P.V.P.		
	ASP.	IMP.	kW	Hp	1~230V	3~400V	Kg		m ³ /h	0	1	2	3	4	5	6	MONOF.	TRIF.
									l/min	0	16,6	33,3	50	66,6	83,3	100		
									ALTURA DE CARGA EN METROS									
VERTI 304P	1	1	1,1	1,5	6,0	2,5	17,4	47	46	45	41	36	28	20	346,60	349,60		
VERTI 306P	1	1	1,5	2,0	8,0	3,5	22,9	74	72	69	66	57	47	36	429,80	424,30		
VERTI 308P	1	1	2,2	3,0	14,0	4,5	23,9	98	95	92	86	76	63	47	476,80	470,10		
VERTI 3010P	1	1	2,2	3,0	-	5,0	25,0	116	114	110	102	90	73	57	-	538,10		
VERTI 3012P	1	1	3,0	4,0	-	6,0	33,4	145	142	140	131	115	97	75	-	771,70		

MODELO	DN (Ø")		P ₂		I (A)		PESO	CAUDAL								P.V.P.									
	ASP.	IMP.	kW	Hp	1~230V	3~400V		Kg									MONOF.	TRIF.							
									ALTURA DE CARGA EN METROS																
VERTI 354P	1 ¼	1 ¼	1,5	2,0	9,2	3,5	21,0	m ³ /h	0	2	4	5	6	8	10	14									
								l/min	0	33,3	66,6	83,3	100	133,3	166,6	233,3									
VERTI 356P	1 ¼	1 ¼	2,2	3,0	14	4,9	23,0									465,00	418,00								
VERTI 358P	1 ¼	1 ¼	3,0	4,0	-	6,3	26,0									606,00	483,00								
																81	79	76	74	72	65	58	36	-	610,00

Modelos trifásicos con arranque directo

MODELO	DN (Ø")		P ₂		I (A)		PESO	CAUDAL								P.V.P.									
	ASP.	IMP.	kW	Hp	1~230V	3~400V		Kg									MONOF.	TRIF.							
									ALTURA DE CARGA EN METROS																
VERTI 354P-A	1 ½	1 ¼	1,5	2,0	8,0	3,5	22,6	m ³ /h	0	2	3	4,5	6	7,5	9	10,5									
								l/min	0	33,3	50	75	100	125	150	175									
VERTI 355P-A	1 ½	1 ¼	1,8	2,5	10,0	4,5	23,1									440,10	440,00								
VERTI 356P-A	1 ½	1 ¼	2,2	3,0	-	5,1	23,8									529,00	483,00								
VERTI 358P-A	1 ½	1 ¼	3,0	4,0	-	6,0	32,1									521,00	483,00								
VERTI 3510P-A	1 ½	1 ¼	4,0	5,5	-	8,0	45,6									691,50	610,00								
																130	124	121	114	103	86	66	41	-	793,60

Modelos trifásicos con arranque directo

MODELO	DN (Ø")		P ₂		I (A)		PESO	CAUDAL								P.V.P.									
	ASP.	IMP.	kW	Hp	1~230V	3~400V		Kg									MONOF.	TRIF.							
									ALTURA DE CARGA EN METROS																
VERTI 454P	1 ½	1 ¼	1,5	2,0	9,2	3,5	23,0	m ³ /h	0	6	8	10	12	14	16	18									
								l/min	0	100	133,3	166,7	200	233,3	266,7	300									
VERTI 455P	1 ½	1 ¼	2,2	3,0	14	4,9	25,0									472,00	427,00								
VERTI 456P	1 ½	1 ¼	3,0	4,0	-	6,3	26,0									594,00	526,60								
VERTI 474P-A	1 ½	1 ¼	4,0	5,5	-	8,5	36,5									640,50	483,00								
VERTI 475P-A	1 ½	1 ¼	5,5	7,5	-	11,0	47,7									745,00	483,00								
VERTI 476P-A	1 ½	1 ¼	5,5	7,5	-	12,5	48,3									920,20	483,00								
VERTI 477P-A	1 ½	1 ¼	7,5	10,0	-	13,5	52,8									941,20	483,00								
VERTI 478P-A	1 ½	1 ¼	7,5	10,0	-	15,0	53,4									1.011,40	483,00								
																150	139	134	127	120	108	92	-	-	1.031,80



MODELO	DN (Ø")		P ₂		I (A)		PESO	CAUDAL								P.V.P.									
	ASP.	IMP.	kW	Hp	1~230V	3~400V		Kg									MONOF.	TRIF.							
									ALTURA DE CARGA EN METROS																
VERTI 554P*	1 ½	1 ¼	2,2	3,0	14	4,9	23,0	m ³ /h	0	4	6	8	12	14	18	20									
								l/min	0	66,6	100	133,3	200	233,3	300	333									
VERTI 556P	1 ½	1 ¼	3,0	4,0	-	6,3	29,6									504,80	483,00								
VERTI 557P	1 ½	1 ¼	4,0	5,5	-	8,2	32,0									653,80	483,00								
VERTI 558P	1 ½	1 ¼	4,75	6,5	-	9,6	33,0									876,20	483,00								
VERTI 5510P	1 ½	1 ¼	5,5	7,5	-	10,8	35,0									911,60	483,00								
																133,4	122,4	114,5	105,8	85,6	74	41,9	13	-	1.057,10

(*) Modelo sólo dispone en IE2

ELECTROBOMBA CENTRÍFUGA VERTICAL SERIE VERTI-I

DESCRIPCIÓN

- Electrobombas centrífugas multietapa en ejecución vertical, diseñadas para la presurización de viviendas, sistemas de riego y aplicaciones de bombeo de agua limpia donde se requiera una bomba robusta y compacta.
- Cuerpos de aspiración e impulsión orientables y suministrados con **contrabrida ovalada DIN 2558**.

MATERIALES

- Camisa: **Acero INOX 304**
- Eje: **Acero INOX 304**
- Difusores: **Noryl reforzado**
- Impulsores: **Acero INOX 304**
- Cuerpo aspiración: **Fundición**
- Cuerpo impulsión: **Fundición**
- Carcasa motor: **Aluminio L-2521**

ÁREA DE TRABAJO

- Temperatura máx. del líquido: **60°C**
- Grado de protección: **IP55**
- Aislamiento clase: **F**
- Servicio continuo **S1**



IMPULSORES EN INOX 304



MULTICELULARES VERTICAL

MODELO	DN (Ø")		P ₂		I (A)			PESO	CAUDAL		P.V.P.																
	ASP.	IMP.	kW	Hp	1~230V	3~400V	Kg		m ³ /h	l/min	MONOF.	TRIF.															
VERTI 304I	1	1	1,1	1,5	6,1	2,4	15,8	0	1,2	1,8	2,4	3	3,6	4,2	4,8	5,4	0	20	30	40	50	60	70	80	90	365,00	370,00
VERTI 306I	1	1	1,5	2,0	8,2	3,3	21,7	0	1,2	1,8	2,4	3	3,6	4,2	4,8	5,4	0	20	30	40	50	60	70	80	90	452,00	445,00

Grado de protección: IP44. Aislamiento clase: B

MODELO	DN (Ø")		P ₂		I (A)			PESO	CAUDAL		P.V.P.																
	ASP.	IMP.	kW	Hp	1~230V	3~400V	Kg		m ³ /h	l/min	MONOF.	TRIF.															
VERTI 354I	1 ¼	1	1,1	1,5	6,4	2,9	21,7	0	1,2	2,4	3,6	4,8	6	7,2	7,8	8,7	0	20	40	60	80	100	120	130	145	462,00	462,00
VERTI 355I	1 ¼	1	1,5	2,0	8,0	4,0	23,0	0	1,2	2,4	3,6	4,8	6	7,2	7,8	8,7	0	20	40	60	80	100	120	130	145	555,00	507,00
VERTI 355BI	1 ¼	1	1,8	2,5	9,7	4,3	29,8	0	1,2	2,4	3,6	4,8	6	7,2	7,8	8,7	0	20	40	60	80	100	120	130	145	606,00	527,00
VERTI 356BI	1 ¼	1	2,2	3,0	11,2	4,4	31,0	0	1,2	2,4	3,6	4,8	6	7,2	7,8	8,7	0	20	40	60	80	100	120	130	145	636,00	547,00

Grado de protección: IP44. Aislamiento clase: B

MODELO	DN (Ø")		P ₂		I (A)			PESO	CAUDAL		P.V.P.														
	ASP.	IMP.	kW	Hp	1~230V	3~400V	Kg		m ³ /h	l/min	MONOF.	TRIF.													
VERTI 356I	1 ½	1 ¼	2,2	3,0	-	4,9	20,0	0	2	4	5	6	7	8	10	0	33	67	83	100	117	133	167	-	615,60
VERTI 358I	1 ½	1 ¼	3,0	4,0	-	6,7	30,0	0	2	4	5	6	7	8	10	0	33	67	83	100	117	133	167	-	798,00
VERTI 3510I	1 ½	1 ¼	4,0	5,5	-	8,2	32,0	0	2	4	5	6	7	8	10	0	33	67	83	100	117	133	167	-	906,20

Grado de protección: IP44. Aislamiento clase: B



MODELO	DN (Ø")		P ₂		I (A)			PESO	CAUDAL		P.V.P.														
	ASP.	IMP.	kW	Hp	1~230V	3~400V	Kg		m ³ /h	l/min	MONOF.	TRIF.													
VERTI 554I	1 ½	1 ¼	2,2	3,0	-	4,9	20,0	0	4	6	7	10	13	16	18	0	67	100	117	167	217	267	300	-	605,20
VERTI 556I	1 ½	1 ¼	3,0	4,0	-	6,7	30,0	0	4	6	7	10	13	16	18	0	67	100	117	167	217	267	300	-	839,20
VERTI 557I	1 ½	1 ¼	4,0	5,5	-	8,2	32,0	0	4	6	7	10	13	16	18	0	67	100	117	167	217	267	300	-	889,00

Grado de protección: IP44. Aislamiento clase: B

DESCRIPCIÓN

- Bombeo, trasvase y presurización en sectores doméstico, civil, industrial y agrícola.
- Sistemas de riego para la agricultura e instalaciones deportivas.
- Aumento de presión y sistemas de abastecimiento hídrico.
- Instalaciones de lavado.

MATERIALES

- Camisa: **Acero INOX 304**
- Difusores: **Noryl reforzado con fibra de vidrio**
- Impulsores: **Noryl reforzado con fibra de vidrio**
- Cuerpo aspiración: **Fundición**
- Cuerpo impulsión: **Fundición**
- Tornillería: **Acero INOX 304**

ÁREA DE TRABAJO

- Temperatura máx. del líquido: **80°C**
- Grado de protección: **IP54**
- Aislamiento clase: **F**
- Servicio continuo **S1**
- Arranques máx. por hora: **40**



DISPONIBLE
MOTOR MONOF.



SERIE 230

MODELO	DN	P ₂	I (A)				CON. PESO		CAUDAL											P.V.P.		
			Ø"	kW	Hp	1~230V		µF	Kg	CAUDAL											HIDRÁULICA	TRIFÁSICA
						3~400V				m ³ /h	l/min	0	3	4,2	6	7,2	8,4	9,6	11,4	12,6		
CTV15-5	1 ½	1,1	1,5	7,6	2,4	30	24,3	47	46	44	41	39	36	32	25	20	13	708,00	1.000,00			
CTV20-6	1 ½	1,5	2,0	10,9	3,1	45	25,0	56	55	53	50	46	42	37	29	22	15	750,00	1.103,00			
CTV30-8	1 ½	2,2	3,0	14,5	4,6	60	32,4	75	73	70	65	60	55	49	38	29	20	828,00	1.218,00			
CTV40-11	1 ½	3,0	4,0	-	5,9	-	40,2	103	100	97	91	85	78	70	56	46	33	908,00	1.415,00			
CTV55-14	1 ½	4,0	5,5	-	7,8	-	42,2	138	134	130	122	115	104	93	74	59	43	1.027,00	1.645,00			

PVP: "HIDRÁULICA" pvp de bomba sin motor. "TRIFÁSICA" pvp de la bomba con motor trifásico. Consulte para motor monofásico.

SERIE 330

MODELO	DN	P ₂	I (A)				CON. PESO		CAUDAL											P.V.P.		
			Ø"	kW	Hp	1~230V		µF	Kg	CAUDAL											HIDRÁULICA	TRIFÁSICA
						3~400V				m ³ /h	l/min	0	6	7,2	8,4	9,6	11,4	12,6	13,8	15,6		
CTV30-5	1 ½	2,2	3,0	14,5	4,6	60	30,3	49	46	45	43	41	38	35	32	27	20	14	736,00	1.125,00		
CTV40-7	1 ½	3,0	4,0	-	5,9	-	37,5	68	61	59	57	55	52	49	45	39	29	20	800,00	1.306,00		
CTV55-10	1 ½	4,0	5,5	-	7,8	-	39,3	102	94	91	88	84	77	72	66	57	42	29	898,00	1.547,00		
CTV75-14	1 ½	5,5	7,5	-	11,2	-	48,0	138	128	124	120	114	103	98	88	75	54	37	1.105,00	2.040,00		

PVP: "HIDRÁULICA" pvp de bomba sin motor. "TRIFÁSICA" pvp de la bomba con motor trifásico. Consulte para motor monofásico.

SERIE 530

MODELO	DN	P ₂	I (A)				PESO		CAUDAL											P.V.P.	
			Ø"	kW	Hp	1~230V		Kg	CAUDAL											HIDRÁULICA	TRIFÁSICA
						3~400V			m ³ /h	l/min	0	11,4	13,8	15,6	18	19,8	21,6	24,0	27		
CTV40-4	2	3,0	4,0	-	5,9	42,4	40	36	35	34	33	32	30	27	22	16	10	935,00	1.455,00		
CTV55-6	2	4,0	5,5	-	7,8	43,9	60	53	52	51	49	48	45	40	33	24	16	1.039,00	1.709,00		
CTV75-8	2	5,5	7,5	-	11,2	51,2	80	70	69	67	65	64	61	53	43	33	21	1.149,00	2.112,00		
CTV100-11	2	7,5	10	-	15,7	63,4	110	97	95	93	90	87	83	73	60	44	29	1.282,00	2.343,00		
CTV125-14	2	9,2	12,5	-	18,5	70,7	139	123	120	118	114	111	106	94	76	56	37	1.427,00	3.074,00		

PVP: "HIDRÁULICA" pvp de bomba sin motor. "TRIFÁSICA" pvp de la bomba con motor trifásico. Consulte para motor monofásico.

SERIE 700

MODELO	DN	P ₂	I (A)				PESO		CAUDAL											P.V.P.	
			Ø"	kW	Hp	1~230V		Kg	CAUDAL											HIDRÁULICA	TRIFÁSICA
						3~400V			m ³ /h	l/min	0	18	19,8	21,6	24	27	30	33	36		
CTV55-3	2	4,0	5,5	-	7,8	43,5	41	35	34	33	31	28	25	22	18	14	9	988,00	1.657,00		
CTV75-5	2	5,5	7,5	-	11,2	51,6	68	59	57	55	51	46	41	35	28	21	14	1.137,00	2.100,00		
CTV100-6	2	7,5	10	-	15,7	62,8	84	68	66	63	59	54	48	42	34	27	17	1.219,00	2.277,00		
CTV125-8	2	9,2	12,5	-	18,5	70,2	113	93	91	87	83	76	69	60	50	40	29	1.355,00	2.998,00		
CTV150-10	2	11	15	-	23,0	77,6	141	116	114	110	104	96	86	75	62	50	36	1.484,00	3.134,00		

PVP: "HIDRÁULICA" pvp de bomba sin motor. "TRIFÁSICA" pvp de la bomba con motor trifásico. Consulte para motor monofásico.



ELECTROBOMBA CENTRÍFUGA VERTICAL SERIE VERTINOX



DESCRIPCIÓN

- Electrobombas centrífugas multietapa en ejecución vertical, diseñadas para la presurización de viviendas, sistemas de riego y aplicaciones de bombeo de agua limpia donde se requiera una bomba robusta y compacta.
- Cuerpos de **aspiración e impulsión INLINE** (posición horizontal alineada)
- En potencias de 0,75 kW a 7,5 kW el motor es B14(v18). Para potencias superiores es B5.

MATERIALES

- Todas las partes en contacto con el líquido bombeado están fabricadas en **Acero INOX 316L**
- Cierre mecánico: **Sic/Carb/EPDM o Vitón**

ÁREA DE TRABAJO

- Temperatura máx. del líquido: **104°C**
- Temperatura mín. del líquido: **-20°C**
- Temperatura máx. ambiente: **50°C**
- Servicio continuo **S1**



DISPONIBLE
CONEXIÓN VICTAULIC



DISPONIBLE EN
50Hz Y 60Hz

MULTICELULARES VERTICAL

SERIE 1

MODELO	DN Ø (mm)		P ₂		PESO	CAUDAL										P.V.P. B										
	ASP.	IMP.	kW	Hp		Kg	m ³ /h	0,4	0,6	0,8	1	1,2	1,4	1,6	1,8		2	2,2	l/min	6,7	10	13,3	16,7	20	23,3	26,7
VERTINOX1-12	32	32	0,75	1,0	26	ALTURA DE CARGA EN METROS										TRIF.										
VERTINOX1-13	32	32	0,75	1,0	27	70	69	68	66	64	62	58	55	49	43	960,00										
VERTINOX1-15	32	32	0,75	1,0	28	75	74,5	74	72	69	66	63	59	54	47	985,00										
VERTINOX1-17	32	32	1,1	1,5	31	87	86	85	84	80,5	77	72	68	62	53	1.033,00										
VERTINOX1-19	32	32	1,1	1,5	32	99	97,5	97	95	91	87	81,5	77	69	59	1.125,00										
VERTINOX1-21	32	32	1,1	1,5	33	110,5	109	108	106	101	97	91	86	78	66	1.173,00										
VERTINOX1-23	32	32	1,1	1,5	34	122	120,5	119,5	116	112	108	101	95	86	73	1.247,00										
VERTINOX1-25	32	32	1,5	2,0	39	135	132,5	130	126	122	117	111	104	94	80	1.296,00										
VERTINOX1-27	32	32	1,5	2,0	40	147	144	141	138	133	128	121	114	103	87	1.365,00										
VERTINOX1-30	32	32	1,5	2,0	41	158	156	154	150	144	138	130	121	112	96	1.413,00										
VERTINOX1-33	32	32	2,2	3,0	44	175	173	171	166	160	154	145	136	124	108	1.520,00										
VERTINOX1-36	32	32	2,2	3,0	45	193	191	188	183	176	170	160	150	136	120	1.682,00										
						212	209	205	200	192	184	174	164	150	133	1.754,00										

P.V.P. suplemento conexión Victaulic®: 295,00 €

SERIE 2

MODELO	DN Ø (mm)		P ₂		PESO	CAUDAL										P.V.P. B						
	ASP.	IMP.	kW	Hp		Kg	m ³ /h	1	1,2	1,6	2	2,4	2,8	3,2	3,5		l/min	16,7	20	26,7	33,3	40
VERTINOX2-9	32	32	1,1	1,5	27	ALTURA DE CARGA EN METROS										TRIF.						
VERTINOX2-11	32	32	1,1	1,5	27	72	71	67	63	58	51	44	36	932,00								
VERTINOX2-13	32	32	1,5	2,0	29	87	85	80	74	67	59	50	42	982,00								
VERTINOX2-15	32	32	1,5	2,0	29	106	104	99	90	81	71	60	51	1.067,00								
VERTINOX2-18	32	32	2,2	3,0	35	121	119	112	105	96	85	72	61	1.130,00								
VERTINOX2-22	32	32	2,2	3,0	38	143	139	133	125	116	105	91	78	1.304,00								
VERTINOX2-26	32	32	3,0	4,0	44	173	169	162	152	140	126	110	95	1.430,00								
						206	201	191	180	170	155	133	118	1.616,00								

P.V.P. suplemento conexión Victaulic®: 295,00 €

ELECTROBOMBA CENTRÍFUGA VERTICAL SERIE VERTINOX

SERIE 3

MODELO	DN Ø (mm)		P ₂			PESO			CAUDAL								P.V.P. B
	ASP.	IMP.	kW	Hp	Kg	m ³ /h								TRIF.			
						l/min	1,2	1,6	2	2,4	2,8	3	3,2		3,4	3,6	
VERTINOX3-11	32	32	1,1	1,5	27	20	26,7	33,3	40	46,7	50	53,3	56,7	60	66,7	971,00	
VERTINOX3-12	32	32	1,1	1,5	27	71	68	66	61	55	52	49	45,5	42	34	995,00	
VERTINOX3-13	32	32	1,1	1,5	28	77	74	71	66	60	57	53	50	46	37	1.019,00	
VERTINOX3-15	32	32	1,1	1,5	29	88	85	82	77	72	68,5	64	60	55	44	1.067,00	
VERTINOX3-17	32	32	1,5	2,0	34	100	97	93	88	83	79	74	69	64	52	1.145,00	
VERTINOX3-19	32	32	1,5	2,0	35	112	108	104	98	92	88	83	77	71	58	1.194,00	
VERTINOX3-21	32	32	2,2	3,0	38	123	119	115	108	102	94	92	86	79	65	1.357,00	
VERTINOX3-23	32	32	2,2	3,0	39	134	130	125	119	110	105	100	94	86	72	1.405,00	
VERTINOX3-25	32	32	2,2	3,0	40	146	141	135	128	118	113	108	102	94	79	1.454,00	
VERTINOX3-27	32	32	2,2	3,0	41	158	152	146	138	129	123	117	110	103	86	1.502,00	
VERTINOX3-29	32	32	2,2	3,0	42	169	163	156	147	137	132	125	118	111	93	1.584,00	
VERTINOX3-31	32	32	3,0	4,0	46	180	174	167	157	147	141	134	126	118	100	1.692,00	
VERTINOX3-33	32	32	3,0	4,0	47	191	186	178	168	157	150	143	135	127	108	1.740,00	
VERTINOX3-36	32	32	3,0	4,0	49	209	203	194	184	173	166	159	151	143	122	1.813,00	

P.V.P. suplemento conexión Victaulic®: 295,00 €

SERIE 4

MODELO	DN Ø (mm)		P ₂			PESO			CAUDAL								P.V.P. B
	ASP.	IMP.	kW	Hp	Kg	m ³ /h								TRIF.			
						l/min	1	2	3	4	4,5	5	5,5		6		
VERTINOX4-7	32	32	1,5	2,0	30	71	69	65	59	55	50	43	36			889,00	
VERTINOX4-8	32	32	1,5	2,0	30	83	80	78	71	65	59	51	42			941,00	
VERTINOX4-10	32	32	2,2	3,0	32	103	100	95	87	80	72	63	54			1.071,00	
VERTINOX4-12	32	32	2,2	3,0	32	122	119	113	103	96	88	78	68			1.139,00	
VERTINOX4-14	32	32	3,0	4,0	35	139	134	128	118	111	102	90	79			1.278,00	
VERTINOX4-16	32	32	3,0	4,0	39	158	153	145	134	126	116	103	89			1.331,00	
VERTINOX4-19	32	32	4,0	5,5	44	186	180	170	155	145	133	117	98			1.616,00	
VERTINOX4-22	32	32	4,0	5,5	48	216	208	197	182	172	159	143	126			1.722,00	

P.V.P. suplemento conexión Victaulic®: 295,00 €

SERIE 5

MODELO	DN Ø (mm)		P ₂			PESO			CAUDAL										P.V.P. B
	ASP.	IMP.	kW	Hp	Kg	m ³ /h										TRIF.			
						l/min	2	3	4	4,5	5	5,5	6	6,5	7		7,5	8	
VERTINOX5-9	32	32	1,5	2,0	35	56	53	50	47,5	45	42,5	40	37	33,5	30,5	27	982,00		
VERTINOX5-10	32	32	1,5	2,0	36	62	59	55	53	50	47	44	41	37	34	30	1.011,00		
VERTINOX5-11	32	32	2,2	3,0	37	68,5	65,5	61,5	59	56	52	49	45	41	37	33	1.129,00		
VERTINOX5-12	32	32	2,2	3,0	38	75	72,5	68	65	62	58	54	49	45	40,5	36	1.166,00		
VERTINOX5-13	32	32	2,2	3,0	39	81,5	79	74	71	68	64	59,5	54	49	44	39	1.220,00		
VERTINOX5-14	32	32	2,2	3,0	40	89	85	81	77	74	69	65	59	54	48	42	1.249,00		
VERTINOX5-15	32	32	2,2	3,0	41	96	93	88	84	80	75	70	64	59	52	45	1.277,00		
VERTINOX5-16	32	32	2,2	3,0	42	103	100	94	90	85	80	75	69	63	56	48	1.306,00		
VERTINOX5-18	32	32	3,0	4,0	45	115	110	104	100	96	90	85	78	71	63	54	1.448,00		
VERTINOX5-20	32	32	3,0	4,0	46	129	122	115	109	105	99	94	86	78	70	60	1.513,00		
VERTINOX5-22	32	32	4,0	5,5	58	139	134	126	121	116	110	103	95	87	77	66	1.776,00		
VERTINOX5-24	32	32	4,0	5,5	59	152	146	138	133	127	120	113	105	96	84	72	1.858,00		
VERTINOX5-26	32	32	4,0	5,5	61	164	158	150	144	138	131	122	114	104	91	78	1.916,00		
VERTINOX5-29	32	32	4,0	5,5	63	185	177	168	164	157	150	141	132	119	103	87	2.038,00		
VERTINOX5-32	32	32	5,5	7,5	77	205	197	189	183	176	166	158	147	134	114	96	2.527,00		
VERTINOX5-36	32	32	5,5	7,5	79	230	222	212	205	198	188	177	166	154	133	108	2.673,00		

P.V.P. suplemento conexión Victaulic®: 295,00 €

SERIE 10

MODELO	DN Ø (mm)		P ₂			PESO	CAUDAL							P.V.P. B
	ASP.	IMP.	kW	Hp	Kg		m ³ /h							
							l/min	2	4	6	8	10	12	
							ALTURA DE CARGA EN METROS							TRIF.
VERTINOX10-6	40	40	2,2	3,0	50	62	61	58	53	46	38	28	1.333,00	
VERTINOX10-7	40	40	3,0	4,0	55	73	72	67	61	54	43	32	1.523,00	
VERTINOX10-8	40	40	3,0	4,0	56	83	81	78	71	62	51	37	1.553,00	
VERTINOX10-9	40	40	3,0	4,0	57	93	91	87	81	71	59	42	1.601,00	
VERTINOX10-10	40	40	4,0	5,5	60	104	101	98	91	81	67	47	1.841,00	
VERTINOX10-12	40	40	4,0	5,5	63	123	121	117	108	95	78	55	1.946,00	
VERTINOX10-14	40	40	5,5	7,5	93	143	141	136	124	110	90	63	2.493,00	
VERTINOX10-16	40	40	5,5	7,5	95	163	161	154	143	125	102	71	2.599,00	
VERTINOX10-18	40	40	7,5	10	120	183	179	173	161	144	118	82	2.831,00	
VERTINOX10-20	40	40	7,5	10	123	202	198	191	180	160	133	93	2.960,00	
VERTINOX10-22	40	40	7,5	10	125	222	217	209	198	178	149	106	3.065,00	

P.V.P. suplemento conexión Victaulic®: 375,00 €

SERIE 15

MODELO	DN Ø (mm)		P ₂			PESO	CAUDAL										P.V.P. B
	ASP.	IMP.	kW	Hp	Kg		m ³ /h										
							l/min	8	10	12	14	15	16	18	20	22	
							ALTURA DE CARGA EN METROS										TRIF.
VERTINOX15-3	50	50	3,0	4,0	50	39	38	37	34	33	31	29	27	24	20	1.324,00	
VERTINOX15-4	50	50	4,0	5,5	55	52	50	48	46	44	43	40	36	31	26	1.580,00	
VERTINOX15-5	50	50	4,0	5,5	58	66	64	61	58	56	54	50	45	39	33	1.656,00	
VERTINOX15-6	50	50	5,5	7,5	90	80	78	75	70	67	65	60	54	47	41	2.152,00	
VERTINOX15-7	50	50	5,5	7,5	93	94	92	88	83	80	78	71	64	56	50	2.285,00	
VERTINOX15-8	50	50	7,5	10	97	108	105	101	96	93	90	83	75	66	57	2.455,00	
VERTINOX15-9	50	50	7,5	10	98	122	119	115	109	106	103	95	87	77	66	2.532,00	
VERTINOX15-10	50	50	11	15	140	136	133	128	123	120	116	107	98	86	76	3.280,00	
VERTINOX15-12	50	50	11	15	144	158	155	150	144	140	135	126	116	102	89	3.497,00	
VERTINOX15-14	50	50	11	15	147	183	178	172	165	162	156	145	133	118	103	3.682,00	
VERTINOX15-16	50	50	15	20	148	210	204	197	190	185	179	168	153	137	118	3.984,00	
VERTINOX15-17	50	50	15	20	160	224	218	212	203	198	193	181	166	151	129	4.060,00	

SERIE 20

MODELO	DN Ø (mm)		P ₂			PESO Kg	CAUDAL										P.V.P. B
	ASP.	IMP.	kW	Hp	m ³ /h												
							ALTURA DE CARGA EN METROS										
VERTINOX20-4	50	50	5,5	7,5	80	8	10	12	14	16	18	20	24	26	28	1.994,00	
VERTINOX20-5	50	50	5,5	7,5	83	133	167	200	233	267	300	333	400	433	467	2.070,00	
VERTINOX20-6	50	50	7,5	10	87	54	53	52	51	50	46	43	36	32	27	2.217,00	
VERTINOX20-7	50	50	7,5	10	90	68	67	65	63	61	58	55	45	40	33	2.352,00	
VERTINOX20-8	50	50	11	15	130	82	80	78	77	73	70	66	55	48	40	3.125,00	
VERTINOX20-10	50	50	11	15	136	96	94	92	89	86	82	77	65	58	47	3.286,00	
VERTINOX20-12	50	50	15	20	145	110	107	104	102	99	95	89	76	67	56	3.639,00	
VERTINOX20-14	50	50	15	20	148	137	135	132	127	124	118	112	98	86	73	3.825,00	
VERTINOX20-16	50	50	18,5	25	168	164	162	158	154	149	142	136	118	106	90	4.215,00	
VERTINOX20-17	50	50	18,5	25	170	191	189	186	181	176	169	161	140	126	110	4.292,00	
						219	217	214	208	203	198	186	164	147	129		
						234	231	228	223	217	210	202	178	162	142		

SERIE 32

MODELO	DN Ø (mm)		P ₂			PESO Kg	CAUDAL										P.V.P. B
	ASP.	IMP.	kW	Hp	m ³ /h												
							ALTURA DE CARGA EN METROS										
VERTINOX32-2	65	65	4,0	5,5	86	12	16	20	24	28	30	32	36	40	2.872,00		
VERTINOX32-3-2	65	65	4,0	5,5	105	200	267	333	400	467	500	533	600	667	3.086,00		
VERTINOX32-3	65	65	5,5	7,5	105	36	34	32	30	27	26	24	21	17	3.635,00		
VERTINOX32-4	65	65	7,5	10	117	48	45	42	39	36	34	32	27	21	3.848,00		
VERTINOX32-5	65	65	11	15	171	54	52	49	46	42	39	37	31	25	4.877,00		
VERTINOX32-6	65	65	11	15	176	72	69	66	62	56	53	50	42	34	5.072,00		
VERTINOX32-7	65	65	15	20	207	91	87	83	78	71	66	62	53	42	5.457,00		
VERTINOX32-8	65	65	15	20	209	109	105	101	95	87	83	77	65	52	5.745,00		
VERTINOX32-9	65	65	18,5	25	226	127	123	118	112	103	97	91	78	61	6.100,00		
VERTINOX32-10	65	65	18,5	25	231	143	139	134	126	117	111	104	88	70	6.258,00		
VERTINOX32-11	65	65	22	30	271	161	157	152	145	134	126	119	102	80	7.278,00		
VERTINOX32-12	65	65	22	30	276	179	174	169	162	149	142	134	114	88	7.440,00		
VERTINOX32-13	65	65	30	40	395	197	192	186	178	165	157	148	126	97	8.614,00		
VERTINOX32-14	65	65	30	40	400	214	210	203	194	180	171	161	137	107	8.844,00		
						232	227	220	210	197	187	177	150	118			
						250	245	237	227	212	203	192	163	130			

SERIE 45

MODELO	DN Ø (mm)		P ₂		PESO		CAUDAL								P.V.P. B
	ASP.	IMP.	kW	Hp	Kg	m ³ /h	25	30	35	40	45	50	55		
						l/min	417	500	583	667	750	833	917		
VERTINOX45-1-1	80	80	3,0	4,0	86	ALTURA DE CARGA EN METROS								TRIF.	
VERTINOX45-1	80	80	4,0	5,5	86	20	19	18	17	15	13	11	2.502,00		
VERTINOX45-2-2	80	80	5,5	7,5	102	24	23	22	21	19	18	16	2.706,00		
VERTINOX45-2	80	80	7,5	10	102	40	38	36	33	30	27	23	3.434,00		
VERTINOX45-3	80	80	11	15	175	48	46	44	42	39	35	31	3.511,00		
VERTINOX45-4	80	80	15	20	187	72	70	67	63	58	53	45	4.714,00		
VERTINOX45-5	80	80	18,5	25	208	98	94	87	84	77	70	61	5.141,00		
VERTINOX45-6	80	80	22	30	251	123	118	112	105	97	88	77	5.698,00		
VERTINOX45-7	80	80	30	40	315	147	141	135	127	118	107	94	7.216,00		
VERTINOX45-8	80	80	30	40	319	169	164	156	147	136	124	109	8.440,00		
VERTINOX45-9-2	80	80	30	40	323	194	189	180	168	155	141	124	8.816,00		
VERTINOX45-9	80	80	37	50	323	209	202	193	182	169	152	133	9.095,00		
VERTINOX45-10	80	80	37	50	347	219	212	203	191	177	161	141	9.394,00		
VERTINOX45-11	80	80	45	60	413	245	236	225	212	196	179	156	9.666,00		
VERTINOX45-12	80	80	45	60	417	267	259	248	235	217	198	174	11.127,00		
VERTINOX45-13-2	80	80	45	60	421	295	286	273	259	239	219	192	11.408,00		
						309	300	286	270	250	227	199	11.682,00		

SERIE 64

MODELO	DN Ø (mm)		P ₂		PESO		CAUDAL								P.V.P. B
	ASP.	IMP.	kW	Hp	Kg	m ³ /h	30	40	50	60	64	70	80		
						l/min	500	667	834	1000	1067	1167	1333		
VERTINOX64-1-1	100	100	4,0	5,5	105	ALTURA DE CARGA EN METROS								TRIF.	
VERTINOX64-1	100	100	5,5	7,5	110	19	18	16	14	13	11,5	9	2.915,00		
VERTINOX64-2-2	100	100	7,5	10	120	27	25	23	20	19	17	14	3.313,00		
VERTINOX64-2	100	100	11	15	155	37	35	32	28	26	23	17	3.670,00		
VERTINOX64-3-1	100	100	15	20	195	55	51	47	42	40	37	30	4.498,00		
VERTINOX64-3	100	100	18,5	25	195	73	69	63	56	53	48	39	5.047,00		
VERTINOX64-4-2	100	100	18,5	25	205	81	76	70	64	60	55	46	5.306,00		
VERTINOX64-4	100	100	22	30	260	92	87	80	71	66	60	49	5.621,00		
VERTINOX64-5	100	100	30	40	345	107	101	94	85	80	74	61	6.864,00		
VERTINOX64-6-2	100	100	30	40	350	136	129	119	109	103	94	78	8.098,00		
VERTINOX64-6	100	100	37	50	370	147	140	130	118	112	101	81	8.404,00		
VERTINOX64-7-1	100	100	37	50	375	164	156	145	132	125	115	95	8.703,00		
VERTINOX64-7	100	100	45	60	435	185	176	163	147	140	128	106	8.998,00		
VERTINOX64-8-1	100	100	45	60	440	193	183	170	155	147	135	112	10.179,00		
						214	203	189	170	162	149	123	10.475,00		

SERIE 90

		CAUDAL							
m ³ /h		50	60	70	80	85	90	100	110
l/min		834	1000	1167	1334	1417	1500	1667	1834

MODELO	DN Ø (mm)		P ₂		PESO Kg	CAUDAL								P.V.P. B
	ASP.	IMP.	kW	Hp		ALTURA DE CARGA EN METROS								
VERTINOX90-1-1	100	100	5,5	7,5	120	22	20	18	16	15	13	10	6	3.436,00
VERTINOX90-1	100	100	7,5	10	122	30	27	25	23	21	19	15	11	3.511,00
VERTINOX90-2-2	100	100	11	15	165	41	39	36	32	30	28	22	15	4.486,00
VERTINOX90-2	100	100	15	20	198	56	53	49	45	43	40	35	30	4.647,00
VERTINOX90-3-2	100	100	18,5	25	212	68	65	60	55	52	49	41	33	5.474,00
VERTINOX90-3	100	100	22	30	265	83	79	73	67	64	61	54	47	6.723,00
VERTINOX90-4	100	100	30	40	348	110	105	100	92	88	84	75	65	7.982,00
VERTINOX90-5	100	100	37	50	375	140	133	126	117	113	107	95	83	8.601,00
VERTINOX90-6	100	100	45	60	438	168	160	151	141	135	130	117	103	10.098,00



IMPULSORES Y DIFUSORES
ACERO INOX 316

ELECTROBOMBA CENTRÍFUGA VERTICAL SERIE MSV



DESCRIPCIÓN

- Electrobombas apropiadas para aplicaciones civiles e industriales, en particular para equipos de presión, instalaciones contra incendio e instalaciones de lavado.

MATERIALES

- Cuerpo de bomba: **Fundición**
- Eje : **Acero INOX 304**
- Impulsor: **Latón**
- Cierre mecánico: **Cer/Graf**
- Soporte motor: **Fundición**

ÁREA DE TRABAJO

- Temperatura máx. del líquido: **90°C**
- Temperatura mín. del líquido: **-10°C**
- Grado de protección: **IPX5**
- Aislamiento clase: **F**
- Servicio continuo **S1**



MULTICELULARES VERTICAL

		CAUDAL							
m ³ /h		0	6	9	12	15	18	21	24
l/min		0	100	150	200	250	300	350	400

MODELO	DN (mm)		P ₂		I (A)		PESO		P.V.P. E									
	ASP.	IMP.	kW	Hp	3~400V	Kg	TRIF.											
	ALTURA DE CARGA EN METROS																	
MSVA-3	50	40	5,5	7,5	10,1	139,5	88,2	86,3	83,7	78,6	71,2	62,6	53,4	43,2	3.418,00			
MSVA-4	50	40	7,5	10	13,0	156	118	116,7	113	106,5	96,8	85,2	73,1	59,7	4.013,00			
MSVA-5	50	40	9,2	12,5	16,4	173	148,2	145,9	138,8	130	119,8	105,2	90,7	73,8	5.204,00			
MSVA-6	50	40	11	15	19,6	192	177,5	174,2	168,9	158,9	144,2	126,7	107,9	88	5.483,00			
MSVA-8	50	40	15	20	26,3	259	237,8	233,4	227	213,8	194,8	171,4	146	119,5	6.540,00			

		CAUDAL										
m ³ /h		0	12	15	18	21	24	27	30	33	36	39
l/min		0	200	250	300	350	400	450	500	550	600	650

MODELO	DN (mm)		P ₂		I (A)		PESO		P.V.P. E									
	ASP.	IMP.	kW	Hp	3~400V	Kg	TRIF.											
	ALTURA DE CARGA EN METROS																	
MSVB-2	50	40	7,5	10	13,4	136,5	74,5	72,7	71,1	68,7	66,1	62,4	58,3	53,8	49	43,9	38,6	3.323,00
MSVB-3R	50	40	9,2	12,5	16,7	153,5	101,8	98,9	96,2	91,4	87,4	81	74,3	66,5	58,8	50,8	42,4	4.712,00
MSVB-3	50	40	11	15	19,6	157,5	112,7	109,2	106,9	102,9	99,6	94,1	88,1	81,3	74,5	67,2	59,3	4.803,00
MSVB-4	50	40	15	20	26,5	220,5	149,7	146,5	143,4	138,2	133,4	125,4	117,1	107,4	97,8	87,7	76,2	5.550,00
MSVB-5	50	40	18,5	25	33,0	245	187,7	182,9	179,2	172,3	166,7	157,2	146,7	134,9	122,7	109,9	96,2	6.179,00
MSVB-6	50	40	22	30	38,8	265	225,9	220,4	216,3	207,1	201,1	189,6	176,6	162,5	147,5	131,7	115,1	7.026,00

		CAUDAL								
m ³ /h		0	18	24	30	36	42	48	54	57
l/min		0	300	400	500	600	700	800	900	950

MODELO	DN (mm)		P ₂		I (A)		PESO		P.V.P. E									
	ASP.	IMP.	kW	Hp	3~400V	Kg	TRIF.											
	ALTURA DE CARGA EN METROS																	
MSVC-2R	65	50	11	15	21,4	167	78,4	79,5	76,3	72,3	67,6	61,8	55,2	46,9	41,8	4.637,00		
MSVC-3R	65	50	15	20	28,9	234	110,4	111,9	107,2	101,5	94,5	85,8	75,3	61,5	53	5.878,00		
MSVC-3	65	50	18,5	25	34	249	127,6	128,8	124,7	118,8	111,9	104	95,1	85,3	79,2	6.197,00		
MSVC-4R	65	50	22	30	41,5	273	159,5	159	153,6	145,7	136,3	125	112,2	98,1	88,3	7.218,00		
MSVC-5	65	50	30	40	59,4	321,5	214,7	215,7	208,6	198,9	187,2	173,9	158,5	141,2	130,9	9.554,00		
MSVC-6	65	50	37	50	72,8	360,5	256,5	257,1	249,2	238,2	224,6	209	191,3	170,7	158,9	10.141,00		

		CAUDAL										
m ³ /h		0	30	36	42	48	54	60	66	72	78	84
l/min		0	500	600	700	800	900	1000	1100	1200	1300	1400

MODELO	DN (mm)		P ₂		I (A)		PESO		P.V.P. E									
	ASP.	IMP.	kW	Hp	3~400V	Kg	TRIF.											
	ALTURA DE CARGA EN METROS																	
MSVD-2	65	50	15	20	27,6	219	75,9	75,9	73,8	71	67,8	64,3	60,4	56,1	51,6	46,4	41	5.159,00
MSVD-3R	65	50	18,5	25	33,7	247	99,6	99,6	96	91,7	87,5	82,7	77,1	70,8	64	56,6	48,5	6.323,00
MSVD-3	65	50	22	30	39,3	257,5	113,1	113,9	110,8	106,7	102	96,9	91,4	85,4	78,8	71,2	63	6.633,00
MSVD-4	65	50	30	40	57,2	305	152	152,5	148,9	144,1	138,7	132,4	125,1	117	108,1	98,8	89	9.112,00
MSVD-5	65	50	37	50	71,9	342,5	189,6	191,4	186,4	179,9	173,3	165,7	157	147	136	124,5	112,3	9.674,00



CENTRÍFUGAS MONOBLOC
GRAN CAUDAL
ASPIRACIÓN PROFUNDA



ELECTROBOMBA CENTRÍFUGA MONOETAPA SERIE CD

DESCRIPCIÓN

- Electrobombas centrífugas monoetapa para tratamientos de agua, limpieza industrial, lavavajillas, rociadores de jardín, aire acondicionado.
- Ideales para abastecimiento y presurización de agua.

MATERIALES

- Cuerpo bomba: **Fundición**
- Eje: **Acero INOX 304**
- Impulsor: **Bronce**
- Cierre mecánico: **Cer/Graf**
- Acoplamiento motor: **Fundición de acero**



ÁREA DE TRABAJO

- Temperatura máx. del líquido: **60°C**
- Grado de protección: **IP44**
- Aislamiento clase: **B**
- Agua limpia con partículas en suspensión
- Líquidos no inflamables
- Autoaspirante: **Hasta 5 m con válvula de pie**



IMPULSOR BRONCE

MODELO	DN Ø"	P ₂		I (A)		PESO Kg	CAUDAL												P.V.P.		B													
		kW	Hp	1~230V	3~400V		m³/h	ALTURA DE CARGA EN METROS												MONOF.		TRIF.												
								0	0,6	1,2	2,4	3	3,6	4,2	4,8	5,4	6	6,6	7,2				7,8											
CD100	1	0,75	1,0	5,1	2,6	9	0	10	20	40	50	60	70	80	90	100	110	120	130	32	30,5	29	25,8	24	22,5	20,5	18,5	16	13	10	201,00	201,00		
CD150	1	1,1	1,5	8,5	3,4	23	0	10	20	40	50	60	70	80	90	100	110	120	130	36	35	34	31,5	30	28,5	26,5	25	23	20,5	18	15,5	295,00	291,00	
CD200	1	1,5	2,0	8,1	5,0	27	0	10	20	40	50	60	70	80	90	100	110	120	130	41	40	39	36,5	35	33,5	32	30	27,5	25	22	18,5	15	307,00	303,00

ELECTROBOMBA CENTRÍFUGA MONOBLOC SERIE CRP

DESCRIPCIÓN

- Electrobomba apropiada para aplicaciones agrícolas pequeñas y medianas.
- Dotadas de turbina abierta para permitir el paso de pequeños cuerpos sólidos de **10 mm máximo de diámetro**.

MATERIALES

- Cuerpo bomba: **Fundición**
- Eje: **Acero INOX 420**
- Turbina: **Noryl**
- Cierre mecánico: **Cer/Graf**
- Soporte motor: **Fundición**



ÁREA DE TRABAJO

- Temperatura máx. del líquido: **35°C**
- Grado de protección: **IP44**
- Aislamiento clase: **F**
- Servicio continuo **S1**



MODELO	DN Ø"	P ₂		I (A)		PESO Kg	CAUDAL												P.V.P.		A					
		kW	Hp	1~230V	3~400V		m³/h	ALTURA DE CARGA EN METROS												MONOF.		TRIF.				
								0	4,2	4,8	7,2	10	12	14,4	17,7	20,4										
CRP100	1 ½	0,75	1,0	5,3	2,4	13,5	0	70	80	120	160	200	240	295	340	19	18,7	18,5	18	17	16,2	14,7	12,7	9,8	223,00	227,00

ELECTROBOMBA CENTRÍFUGA MONOBLOC SERIE CHP



DESCRIPCIÓN

- Electrobomba centrífuga de un solo impulsor de baja altura para sistemas de riego con caudales elevados.
- Para aplicaciones en sistemas de riego por caudal en jardinería y agricultura y en equipamientos industriales.



MATERIALES

- Cuerpo de bomba: **Fundición**
- Eje: **AISI 1045**
- Impulsor: **Fundición**
- Doble cierre mecánico: **Graf-Cer/ NBR-SS304**

ÁREA DE TRABAJO

- Temperatura máx. del líquido: **90°C**
- Grado de protección: **IP44**
- Aislamiento clase: **B**
- Agua limpia o líquidos no agresivos



CAUDAL										
m ³ /h	0	6	8,3	10,9	12,9	17,4	21,8	24	28,6	30,9
l/min	0	100	138	182	215	290	363	400	477	515

MODELO	DN		P ₂		I (A)		ALTURA DE CARGA EN METROS								P.V.P.			
	Ø"	mm	kW	Hp	1~230V	3~400V									MONOF.	TRIF.		
CHP200	2	50	1,5	2,0	9,0	3,1	22,2	21,6	21	20,9	20,6	20,1	19,2	18,7	17,6	12,9	295,00	295,00

ELECTROBOMBA CENTRÍFUGA MONOBLOC SERIE CH

DESCRIPCIÓN

- Electrobombas centrífugas que combinan alturas medias con caudales medios-altos.
- Apropriadadas para riegos por aspersión en general, donde además del silencio se solicita una leve oscilación de presión cuando varía el caudal.



MATERIALES

- Cuerpo de bomba: **Fundición**
- Eje: **Acero INOX 303**
- Impulsor: **Latón/Fundición**
- Cierre mecánico: **Cer/Graf-NBR**
- Soporte motor: **Fundición**

ÁREA DE TRABAJO

- Temperatura máx. del líquido: **90°C**
- Grado de protección: **IPX4**
- Aislamiento clase: **F**



CAUDAL									
m ³ /h	0	6	9	12	15	18	21	24	27
l/min	0	100	150	200	250	300	350	400	450

MODELO	DN		P ₂		I (A)		PESO	ALTURA DE CARGA EN METROS								P.V.P.		
	Ø"	mm	kW	Hp	1~230V	3~400V		Kg									MONOF.	TRIF.
CH150	2	50	1,5	2,0	8,2	3,7	22	24,8	24,6	23,7	22,3	20,5	18,4	15,8	12,8	9	612,00	591,00
CH200	2	75	1,85	2,5	10,4	4,3	24	28,3	28	27,1	25,7	23,9	21,9	19,3	16,4	13	637,00	604,00
CH300	2	100	2,2	3,0	12,3	5,2	32	31,6	31,2	30,3	29	27,3	25,3	22,7	19,7	16,6	1.114,00	617,00

CAUDAL								
m ³ /h	6	12	18	24	30	33	36	39
l/min	100	200	300	400	500	550	600	650

MODELO	DN (Ø")		P ₂		I (A)		PESO	ALTURA DE CARGA EN METROS								P.V.P.	
	ASP.	IMP.	kW	Hp	1~230V	3~400V		Kg									MONOF.
CH350	3	2	2,2	3,0	12,7	5,2	34,5	25,6	25,3	23,5	20,5	16,2	13,5	10	-	1.126,00	1.039,00
CH400	3	2	3,0	4,0	17,0	6,9	38,7	30,8	30,7	29,1	26,1	22	19,5	16,7	13,6	1.341,00	1.210,00
CH550	3	2	4,0	5,5	-	9,1	38,7	37,8	37,9	36,8	34,3	30,2	28,2	25,5	20,7	-	1.348,00



ELECTROBOMBA CENTRÍFUGA MONOBLOC SERIE BP

DESCRIPCIÓN

- Electrobombas diseñadas para el trasiego de grandes caudales, sistemas de riego por aspersión, levantamiento de agua de lagos, ríos y tanques, así como para diversas aplicaciones industriales.

MATERIALES

- Cuerpo de bomba: **Fundición**
- Impulsor: **Latón estampado**
- Cierre mecánico: **Cer/Graf**
- Soporte motor: **Fundición**

ÁREA DE TRABAJO

- Temperatura máx. del líquido: **50°C**
- Grado de protección: **IP44**
- Aislamiento clase: **F**
- Servicio continuo



		CAUDAL										
m ³ /h		0	10	12	15	18	20	25	30	32	36	40
l/min		0	167	200	250	300	333	417	500	533	600	667

MODELO	DN	P ₂		I (A)		COND. PESO		CAUDAL										P.V.P.		
		ø"	kW	Hp	1~230V	3~400V	μF	Kg	ALTURA DE CARGA EN METROS										MONOF.	TRIF.
BP 4	2	1,1	1,5	8,8	3,5	32	19,2	22	21	20,6	20	19	18,2	15	11,5	10	653,90	670,10		
BP 5	2	1,5	2,0	12,6	4,9	40	22	24	23,7	23,5	23	22	21,5	19	15	14,0	9	6	708,60	737,20

CENTRÍFUGA MONOBLOC GRAN CAUDAL SERIE CSP

DESCRIPCIÓN

- Electrobombas de aspiración axial con impulsor cerrado.
- Especialmente adecuadas para su uso en sistemas de riego, canales móviles y sistemas de almacenamiento en depósito.

MATERIALES

- Cuerpo de bomba: **Hierro fundido**
- Eje: **Acero INOX 416**
- Impulsor: **Fundición**
- Cierre mecánico: **Cer/Graf**
- Soporte motor: **Hierro fundido**
- Rotor: **Hierro fundido**

ÁREA DE TRABAJO

- Temperatura máx. del líquido: **80°C**
- Grado de protección: **IP44**
- Aislamiento clase: **F**
- Servicio continuo **S1**



		CAUDAL									
m ³ /h		6	12	18	24	30	36	42	48	54	63
l/min		100	200	300	400	500	600	700	800	900	1050

MODELO	DN	P ₂		I (A)		COND. PESO		CAUDAL										P.V.P.	
		ø"	kW	Hp	1~230V	3~400V	μF	Kg	ALTURA DE CARGA EN METROS										MONOF.
CSP100	2	0,75	1,0	5,0	1,3	20	14	13	12,6	11	8,4	206,90	211,10						
CSP150	2	1,1	1,5	8,0	2,8	32	23	13	12,8	11,5	11,4	10	8,5	6	334,00	345,00			
CSP200	2	1,5	2,0	10,0	3,8	32	24	15,2	14,5	14	13,2	12,2	10	7,5	6	366,50	366,50		
CSP300	3	2,2	3,0	-	4,5	-	26	17,5	17,6	17	16	15,5	13	12	9	6,2	-	491,40	
CSP400	3	3,0	4,0	-	6,5	-	41,1	20,6	20,6	20,2	19,5	19,0	18,5	17,5	16	14,5	10,5	-	501,90

CENTRÍFUGA MONOBLOC GRAN CAUDAL SERIE CST

DESCRIPCIÓN

- Electrobombas centrífugas con un rodete de desplazamiento de caudal medio y alto caracterizadas por bocas de salida 3" y 4".
- Encuentran aplicación primaria en el campo de la agricultura y en todas las aplicaciones en las que se solicita un caudal consistente.



MATERIALES

- Cuerpo de bomba: **Fundición**
- Eje: **Acero INOX 420**
- Impulsor: **Latón**
- Cierre mecánico: **Cer/Graf**
- Soporte motor: **Fundición**

ÁREA DE TRABAJO

- Temperatura máx. del líquido: **90°C**
- Grado de protección: **IPX4**
- Aislamiento clase: **F**
- Servicio continuo **S1**



		CAUDAL						
m ³ /h		0	36	48	60	72	84	96
l/min		0	600	800	1000	1200	1400	1600

MODELO	DN		P ₂		I (A)		PESO	ALTURA DE CARGA EN METROS							P.V.P. A
	ø"	ø"	kW	Hp	3~400V	Kg		TRIF.							
CST450	4	4	3,0	4,0	6,2	41,1		14,5	14,1	13,4	12,1	10,3	8,3	6,1	1.205,00
CST550	4	4	4,0	5,5	8,8	41,1		17	17,3	16,8	15,7	14,4	12,2	10	1.226,00

ELECTROBOMBA CENTRÍFUGA ASPIRACIÓN PROFUNDA SERIE PDP

DESCRIPCIÓN

- Electrobombas de agua autocebantes para pozos profundos.
- Instaladas en superficie con el cuerpo del surtidor sumergido garantizan su funcionamiento incluso cuando el nivel estático del agua del pozo desciende **hasta 35 metros por debajo del nivel de la bomba.**
- Para usos en aplicaciones domésticas y en la distribución automática de agua, depósitos de compensación pequeños y medianos, riego de jardines, etc.



MATERIALES

- Cuerpo de bomba: **Fundición**
- Soporte motor: **Fundición**
- Carcasa motor: **Aluminio**
- Impulsor: **Latón**
- Difusor: **Noryl**
- Eje motor: **Acero al carbono (ASIS 304 bajo pedido)**
- Cierre mecánico: **SiC/Graf.**

ÁREA DE TRABAJO

- Temperatura máx. del líquido: **60°C**
- Grado de protección: **IP44**
- Aislamiento clase: **B**
- Servicio continuo **S1**



EYECTOR



		CAUDAL															
m ³ /h		0	0,1	0,2	0,4	0,5	0,6	0,8	1	1,1	1,2	1,3	1,4	1,6	1,7	1,8	
l/min		0	2	4	6	8	10	14	16	18	20	22	24	26	28	30	

MODELO	P ₂		DN (ø")		PESO	SUCCIÓN	P.V.P. A	
	kW	Hp	ASP.	IMP.				kg
PDP-505E	1,1	1,5	1 1/4" x 1"	1"	26,0	15	55 52 49 46 42 38 34 30 28 23 20 18	425,00
						20	50 47 43 40 35 32 28 25 22	
						25	40 35 32 28 25 21 19	
						30	35 32 28 25 22	
						35	30 27 24 20	
PDP-750E	1,5	2,0	1 1/4" x 1"	1"	27,0	15	70 68 62 58 53 50 47 44 41 38 35 32 30 28 26	450,00
						20	65 60 56 52 48 45 42 38 35	
						25	60 55 50 45 43 40 35 32	
						30	55 50 46 42 40 36	
						35	50 46 41 37	

INSTALACIÓN ESTÁNDAR DE BOMBA AUTOASPIRANTE

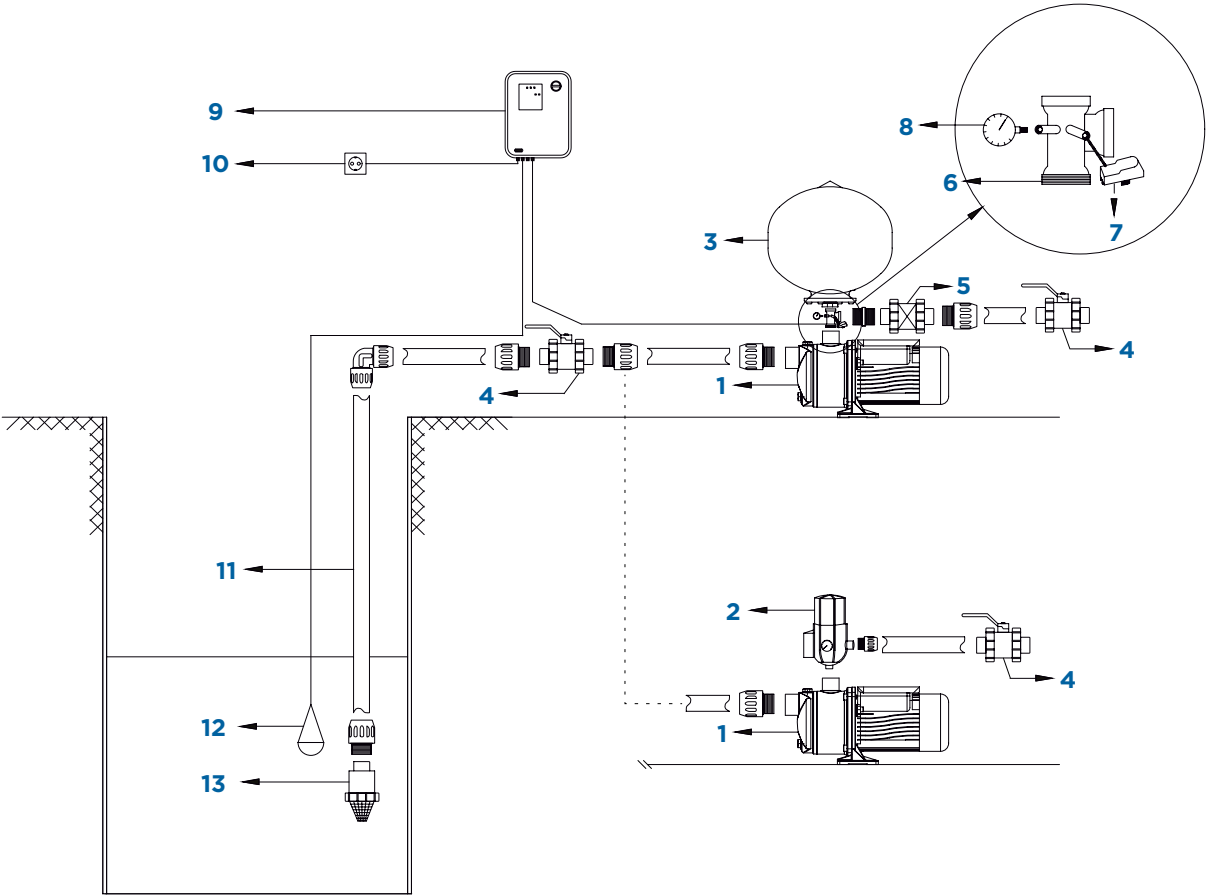

COMPONENTES:

- 1. Electrobomba
- 2. Controlpump
- 3. Hidrosfera 25 lts.
- 4. Válvula de esfera 1"
- 5. Válvula de retención 1"
- 6. Racord 5 vías
- 7. Presostato PM5
- 8. Manómetro M6
- 9. Cuadro de protección
- 10. Tensión de alimentación
- 11. Tubería de aspiración 1"
- 12. Interruptor de nivel
- 13. Válvula de pie 1" con filtro



CENTRÍFUGAS INOX BITURBINA INOX



ELECTROBOMBA CENTRÍFUGA EN ACERO INOX SERIE PWK

DESCRIPCIÓN

- Electrobombas centrífugas de **impulsor abierto tipo vórtex**, principalmente adecuadas para todas aquellas aplicaciones en maquinaria industrial, fundamentalmente en equipos de enfriamiento, chillers, aire acondicionado, etc.

MATERIALES

- Cuerpo de bomba: **Acero INOX 304**
- Eje: **Acero INOX 304**
- Impulsor: **Acero INOX 304**
- Difusor: **Acero INOX 304**
- Carcasa motor: **Material plástico**
- Cierre mecánico: **Carb/Cer/EPDM (juntas en Vitón para altas temperaturas)**
- Base portacierre: **Acero INOX 304**

ÁREA DE TRABAJO

- Temperatura máx. del líquido: **70°C**
- Grado de protección: **IP55**
- Aislamiento clase: **F**
- Presión máx. trabajo: **0.3 MPa**
- Diámetro sólidos: **18 mm (impulsor abierto)**



IMPULSOR ABIERTO



		CAUDAL											
m ³ /h		0	4	8	12	16	20	25,5	28,5	32	36	40	44
l/min		0	67	133,3	200	266,7	333,3	425	475	533,3	600	666,7	733,3

MODELO	DNA DNI		P ₂		I (A)		ALTURA DE CARGA EN METROS							P.V.P.		B				
	Ø"	Ø"	kW	Hp	1~230V	3~400V								MONOF.	TRIF.					
PWK120	1½	1½	1,0	1,3	7,0	2,6	12,5	12	11,5	10,5	9,5	7,8	5			345,00	335,00			
PWK200	2	2	1,5	2,0	9,2	3,5	15	14,5	14	13	12	10,5	8,2	6,5		526,00	473,00			
PWK300	2½	2	2,2	3,0	14	4,9	17,5	17	16,5	16	15	14	13	12,5	11,5	10	9,3	666,00	576,00	
PWK400	2½	2	3,0	4,0	-	6,3	21,5	21	20	19	18,1	17	16,1	15,3	14,5	13,5	13	11	-	642,00

ELECTROBOMBA CENTRÍFUGA EN INOX SERIE PWB

DESCRIPCIÓN

- Electrobombas centrífugas principalmente adecuadas para todas aquellas aplicaciones con maquinaria industrial, fundamentalmente en equipos de enfriamiento, chillers, aire acondicionado, etc.

MATERIALES

- Cuerpo de bomba: **Acero INOX 304**
- Eje: **Acero INOX 304**
- Impulsor: **Acero INOX 304**
- Difusor: **Acero INOX 304**
- Carcasa motor: **Material plástico**
- Cierre mecánico: **Carb/Cer/EPDM (juntas en vitón para altas temperaturas)**
- Base portacierre: **Acero INOX 304**

ÁREA DE TRABAJO

- Temperatura máx. del líquido: **70°C**
- Grado de protección: **IP55**
- Aislamiento clase: **F**
- Presión máx. trabajo: **1.0 MPa**



IMPULSOR CERRADO



		CAUDAL								
m ³ /h		0	3	6	9	12	18	24	30	36
l/min		0	50	100	150	200	300	400	500	550

MODELO	P ₂		I (A)		ALTURA DE CARGA EN METROS							P.V.P.		B		
	kW	Hp	1~230V	3~400V								MONOF.	TRIF.			
PWB50/025	0,25	0,3	2,0	0,7	14,5	12,5	6								215,00	211,00
PWB50/037	0,37	0,5	2,4	1,0	17	14,2	8,3								217,00	212,00
PWB250/055	0,55	0,75	3,8	1,4	11	10,5	10	9	8,5	6	4				290,00	290,00
PWB250/075	0,75	1,0	5,2	1,8	15	14,5	14	13	12	9,5	6,5				311,00	310,00
PWB300/1.1	1,1	1,5	7,0	2,6	21	20,5	19,5	19	18	15	11	6,5			474,00	439,00
PWB300/1,5	1,5	2,0	9,2	3,5	21	20,8	20	19,5	18,5	16,5	14	10,5			529,00	477,00
PWB500/1,5	1,5	2,0	9,2	3,5	26	25	23,5	22,5	21	17,5	13,2	8,5			511,00	496,00
PWB500/2,2	2,2	3,0	14	4,9	26	25,5	25	24,5	23,5	21	19	15	13		651,00	605,00
PWB500/3,0	3,0	4,0	-	6,3	29	28,5	28	27	26,5	24,5	21,8	17,8	15,5	-	-	630,00

ELECTROBOMBA CENTRÍFUGA EN ACERO INOX SERIE PDC

DESCRIPCIÓN

- Electrobombas centrífugas diseñadas para sistemas de limpieza circular o líneas de producción industrial de cualquier campo.
- Sistemas de agua domésticos y unidad de refuerzo.
- Riego por aspersión agrícola y hortícola.
- Sistema y equipos de refrigeración.



MATERIALES

- Cuerpo de bomba: **Acero INOX 316**
- Eje: **Acero INOX 304**
- Impulsor: **Acero INOX 316**
- Difusor: **Acero INOX 316**
- Carcasa motor: **Aluminio**
- Cierre mecánico: **Carb/Cer/EPDM (juntas en Vitón para altas temperaturas)**
- Base portacierre: **Acero INOX 316**

ÁREA DE TRABAJO

- Temperatura máx. del líquido: **70°C**
- Grado de protección: **IP55**
- Aislamiento clase: **F**
- Presión máx. trabajo: **1.0 MPa**

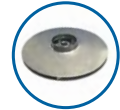

IMPULSOR CERRADO



MODELO	P ₂		I (A)		CAUDAL								P.V.P							
	kW	Hp	1~230V 3~400V		0	1,2	2,4	3,6	4,8	6,0	6,6	ALTURA DE CARGA EN METROS		MONOF.	TRIF.					
			22	20,5								19,2	17,5			16				
PDC70/037	0,37	0,50	2,4	1,0	0	1,2	2,4	3,6	4,8	6,0	6,6	22	20,5	19,2	17,5	16	360,00	355,00		
PDC70/055	0,55	0,75	3,8	1,4	0	20	40	60	80	100	110	30	28	25,5	23,1	20,5	388,00	386,00		
PDC90/075	0,75	1,00	5,2	1,8	0	50	75	100	125	150	175	32	30,2	28,2	26	23,8	21	19,5	405,00	405,00

MODELO	P ₂		I (A)		CAUDAL								P.V.P							
	kW	Hp	1~230V 3~400V		0	3,0	4,5	6,0	7,5	9,0	10,5 <th colspan="2">ALTURA DE CARGA EN METROS</th> <th rowspan="2">MONOF.</th> <th rowspan="2">TRIF.</th>	ALTURA DE CARGA EN METROS		MONOF.	TRIF.					
			22,5	20,5								19,2	17,7			16,3	14,5	12,5		
PDC120/055	0,55	0,75	3,8	1,4	0	3,0	4,5	6,0	7,5	9,0	10,5	22,5	20,5	19,2	17,7	16,3	14,5	12,5	392,00	390,00
PDC120/090	0,90	1,20	5,8	2,1	0	50	75	100	125	150	175	32	29,2	27,5	25,2	23	20,5		446,00	427,00
PDC120/150	1,50	2,00	9,2	3,5	0	40	80	120	160	200	240	40,5	37,5	35,5	33,8	31,8	29,5		551,00	503,00

MODELO	P ₂		I (A)		CAUDAL								P.V.P							
	kW	Hp	1~230V 3~400V		0	2,4	4,8	7,2	9,6	12	14,4 <th colspan="2">ALTURA DE CARGA EN METROS</th> <th rowspan="2">MONOF.</th> <th rowspan="2">TRIF.</th>	ALTURA DE CARGA EN METROS		MONOF.	TRIF.					
			23	21,8								20,5	19			17,5	16	13,5		
PDC200/090	0,90	1,20	5,8	2,1	0	2,4	4,8	7,2	9,6	12	14,4	23	21,8	20,5	19	17,5	16	13,5	443,00	426,00
PDC200/150	1,50	2,00	9,2	3,5	0	40	80	120	160	200	240	34	32,5	31	29	27,5	25,5	23,5	533,00	486,00
PDC200/185	1,85	2,50	13	4,1	0	40	80	120	160	200	240	41	39,8	38	36	33,8	31	28,6	687,00	603,00

ELECTROBOMBA CENTRÍFUGA EN ACERO INOX SERIE 2PDC

DESCRIPCIÓN

- Electrobomba centrífuga birturbina construida en **acero INOX 316** especialmente apropiada para el suministro de agua potable, presurización doméstica, riegos de jardín, lavado a presión, tratamiento de aguas, torres de refrigeración e intercambiadores de calor, etc.
- Integrada a diferentes tipos de maquinaria industrial.



MATERIALES

- Cuerpo de bomba: **Acero INOX 316**
- Eje: **Acero INOX 316**
- Impulsor: **Acero INOX 316**
- Difusor: **Acero INOX 316**
- Carcasa motor: **Aluminio**
- Cierre mecánico: **Carb/Cer/EPDM (juntas en vitón para altas temperaturas)**
- Base portacierre: **Acero INOX 316**

ÁREA DE TRABAJO

- Temperatura máx. del líquido: **70°C**
- Grado de protección: **IP55**
- Aislamiento clase: **F**
- Presión máx. trabajo: **1.0 MPa**

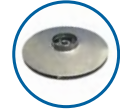

IMPULSOR CERRADO



MODELO	P ₂				I (A)				CAUDAL				P.V.P.	B
	kW		Hp		1~230V		3~400V		ALTURA DE CARGA EN METROS					
	MONOF.	TRIF.	MONOF.	TRIF.	MONOF.	TRIF.	MONOF.	TRIF.	MONOF.	TRIF.	MONOF.	TRIF.		
2PDC70/075	0,75	1,0	5,2	1,8	38,5	35,3	31,5	27	522,00	522,00				
2PDC70/090	0,90	1,2	5,8	2,1	44,5	40,3	35,5	30	551,00	544,00				
2PDC70/110	1,1	1,5	7,0	2,6	52,5	48	42,8	36,5	642,00	610,00				
2PDC70/150	1,5	2,0	9,2	3,5	60	55,6	50,4	44	691,00	644,00				

MODELO	P ₂				I (A)				CAUDAL				P.V.P.	B
	kW		Hp		1~230V		3~400V		ALTURA DE CARGA EN METROS					
	MONOF.	TRIF.	MONOF.	TRIF.	MONOF.	TRIF.	MONOF.	TRIF.	MONOF.	TRIF.	MONOF.	TRIF.		
2PDC120/110	1,1	1,5	7,0	2,6	42	41	39,5	35	30	609,00	578,00			
2PDC120/150	1,5	2,0	9,2	3,5	51,5	49,5	47,4	41,8	36,5	658,00	610,00			
2PDC120/220	2,2	3,0	14	4,9	59	57	54,6	49,2	44	831,00	747,00			
2PDC120/300	3,0	4,0	-	6,3	68,5	66,5	64	58	52	-	817,00			

MODELO	P ₂				I (A)				CAUDAL				P.V.P.	B
	kW		Hp		1~230V		3~400V		ALTURA DE CARGA EN METROS					
	MONOF.	TRIF.	MONOF.	TRIF.	MONOF.	TRIF.	MONOF.	TRIF.	MONOF.	TRIF.	MONOF.	TRIF.		
2PDC200/220	2,2	3,0	14	4,9	52	50,8	48,1	45,5	42,7	39,5	791,00	707,00		
2PDC200/300	3,0	4,0	-	6,3	62,5	61,1	58	55,2	52,3	49	-	812,00		
2PDC200/370	3,7	5,0	-	9,6	71,5	70,1	67	64,3	61,2	57,5	-	955,00		



MONOBLOC NORMALIZADAS

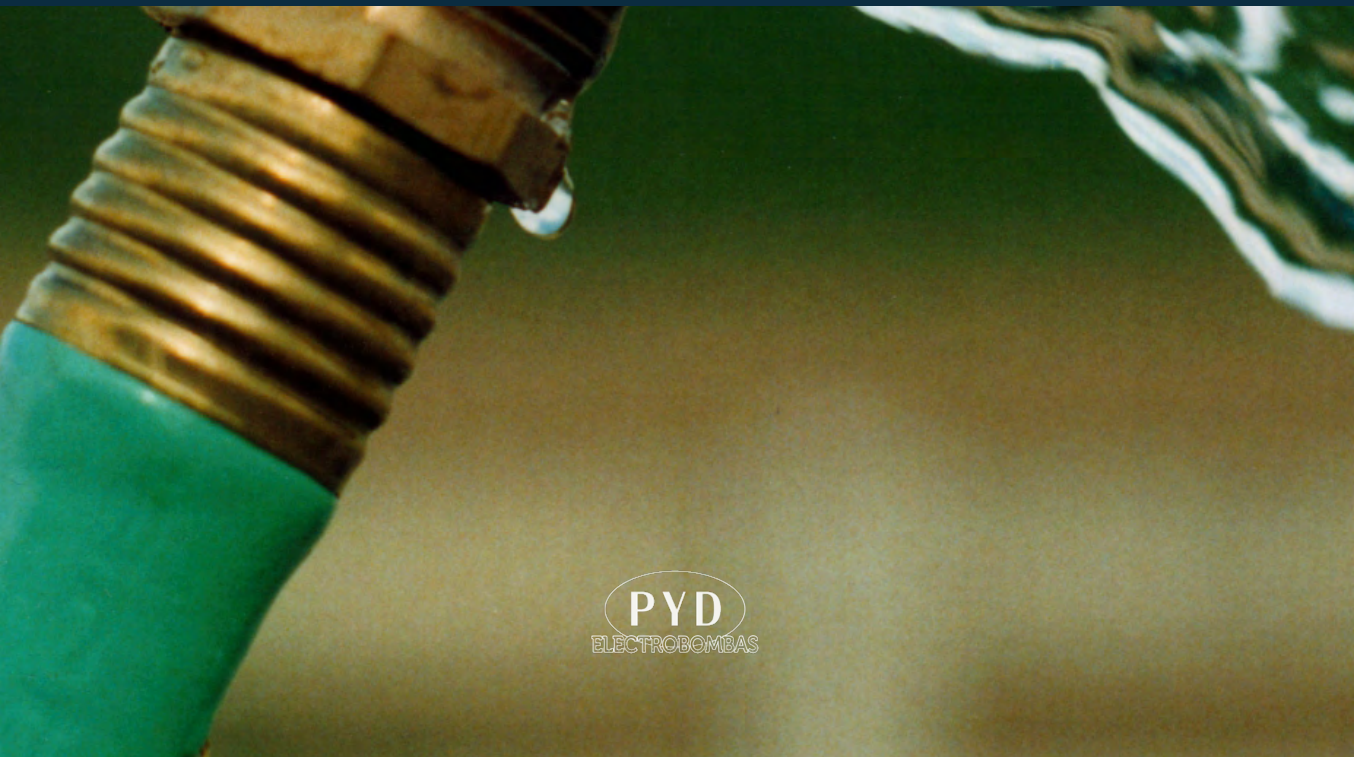

PYD
ELECTROBOMBAS

DESCRIPCIÓN

- Electrobombas centrífugas aptas para la circulación y bombeo de aguas limpias y otros líquidos de características físicas y químicas similares.
- Suministro de agua, irrigación, rociadores, sistemas contra incendios, circulación de agua en sistemas de aire acondicionado, etc.
- Bridas según estándares **UNI 2236 y DIN 2532**.
- Cierre mecánico según norma **DIN 24960**.



MATERIALES

- Cuerpo de bomba: **Fundición**
- Eje: **Acero INOX 316**
- Impulsores: **Acero INOX/Fundición**
- Juntas: **NBR**
- Cierre mecánico: **Cer/Graf**

ÁREA DE TRABAJO

- Temperatura máx. del líquido: **85°C**
- Temperatura mín. del líquido: **-10°C**
- Grado de protección: **IP54**
- Aislamiento clase: **F**
- Presión máx. trabajo: **12 bar**
- Protección por sobrecarga



IMPULSOR



MONOBLOC NORMALIZADAS

MODELO	DN Ø (mm)		P ₂		I (A)		CAUDAL							P.V.P.								
	ASP.	IMP.	kW	Hp	1~230V	3~400V	CAUDAL							MONOF.	TRIF.							
							m ³ /h	l/min	0	6	9	15	18			24	27					
NM32-160/15*	50	32	1,5	2,0	9,4	3,5	0	6	9	15	18	24	27	25,4	23,7	22,5	18,5	15,8	550,00	520,00		
NM32-160/22*	50	32	2,2	3,0	13,4	4,7	0	100	150	250	300	400	450	31	29,6	28,5	24,5	22	15	592,00	552,00	
NM32-160/30*	50	32	3,0	4,0	-	6,4								35	34,3	34	28	25,5	19	15	-	622,90
NM32-200/30*	50	32	3,0	4,0	-	6,4								44,2	43	39,8	35,2	32,2	24,6	19,8	-	768,00
NM32-200/40*	50	32	4,0	5,5	-	8,2								54,5	52	50	45,5	41,9	35	30,3	-	817,00
NM32-250/55	50	32	5,5	7,5	-	11,1								60	59,5	59	55	51	34,5	-	-	1.184,00
NM32-250/75	50	32	7,5	10	-	15,0								69,5	69	68,5	66	63	53	-	-	1.295,00

(*) Modelos con impulsor en acero INOX.

MODELO	DN Ø (mm)		P ₂		I (A)		CAUDAL							P.V.P.									
	ASP.	IMP.	kW	Hp	1~230V	3~400V	CAUDAL							MONOF.	TRIF.								
							m ³ /h	l/min	0	18	24	27	36			42	48						
NM40-125/15	65	40	1,5	2,0	9,4	3,5	0	18	24	27	36	42	48	18,1	17	15	11,5	10,1	5,8	526,00	484,00		
NM40-125/22	65	40	2,2	3,0	13,4	4,7	0	300	400	450	600	700	800	24,5	23,2	21,5	20,2	16	13	8,3	552,00	518,00	
NM40-160/30	65	40	3,0	4,0	18,0	6,4								31,8	29,5	27,5	26,3	21,5	17,5	-	-	718,00	
NM40-160/40	65	40	4,0	5,5	-	8,2								38	36	34	33	28,5	25	20,1	-	-	766,00
NM40-200/55*	65	40	5,5	7,5	-	11,1								46	43,8	41,3	40,1	35	30	-	-	975,00	
NM40-200/75*	65	40	7,5	10	-	15,0								57	53,6	51,5	50	45	41	36,5	-	-	1.021,00
NM40-250/110	65	40	11	15	-	21,8								72	67,5	66	63,5	57,5	52,2	47	-	-	1.642,00
NM40-250/150	65	40	15	20	-	29,4								84,5	80	77,3	75,2	71	65	61	-	-	2.211,00

(*) Modelos con impulsor en acero INOX.

MODELO	DN Ø (mm)		P ₂				I (A)		CAUDAL								P.V.P. B			
									ALTURA DE CARGA EN METROS										MONOF.	TRIF.
									ASP.	IMP.	kW	Hp	1~230V	3~400V	0	36				
NM50-125/30	65	50	3,0	4,0	18,0	6,4	20	18,8	18	17	15,6	11	770,80	722,00						
NM50-125/40	65	50	4,0	5,5	-	8,2	24	23,1	23	21,5	20,3	15,8	-	771,00						
NM50-160/55	65	50	5,5	7,5	-	11,1	32	30,6	30	28	26,6	20,5	14,8	926,00						
NM50-160/75	65	50	7,5	10	-	15,0	40	38	37	36	34,4	29	24	21	972,00					
NM50-200/92	65	50	9,2	12,5	-	19,0	50,5	46,8	45	43	40,9	32,5	25,7	1.524,00						
NM50-200/110	65	50	11	15	-	21,8	57,5	53,5	52	50	47,5	40	33	29	1.663,00					
NM50-250/150	65	50	15	20	-	29,4	68,5	64	63	61,5	59	50	41,0	1.926,00						
NM50-250/185	65	50	18,5	25	-	35,5	79	75,8	74,8	74	71,5	63,5	55,5	47	2.394,00					
NM50-250/220	65	50	22	30	-	42,2	89,5	86	85,3	84	81,5	73,5	65,5	57	2.745,00					

MODELO	DN Ø (mm)		P ₂				I (A)		CAUDAL								P.V.P. B			
									ALTURA DE CARGA EN METROS										MONOF.	TRIF.
									ASP.	IMP.	kW	Hp	3~400V	0	48	54				
NM65-125/55	80	65	5,5	7,5	11,1	23	21,3	20,9	19	17,5	16,7	13,7	-	945,00						
NM65-125/75	80	65	7,5	10	15,0	27	26	25,6	24,5	23	22,5	20	18	992,00						
NM65-160/92	80	65	9,2	12,5	19,0	33	-	31,5	30	28	27,1	24	21,5	1.516,00						
NM65-160/110	80	65	11	15	21,8	36	-	34,5	33	31,5	30,8	28	25,5	1.705,00						
NM65-160/150	80	65	15	20	29,4	42	-	41	40	38,5	37,8	35	33	29,5	2.063,00					
NM65-200/150	80	65	15	20	29,4	45	-	45,5	43	41	40,2	36,5	34	2.211,00						
NM65-200/185	80	65	18,5	25	35,5	52	-	52,3	51	49	48,2	44,5	42,5	2.651,00						
NM65-200/220	80	65	22	30	42,2	59	-	59,5	58	56	55	52	49,5	44,5	2.745,00					
NM65-250/220	80	65	22	30	42,2	64,8	-	64,7	62	60	58,5	53	50	3.020,00						
NM65-250/300	80	65	30	40	56,9	80	-	79,8	77,5	75,5	74,5	70	66	58	3.966,00					

Los modelos superiores a NM65-125 tienen un rango de caudal a partir de los 900 l/m.

MODELO	DN Ø (mm)		P ₂				I (A)		CAUDAL							P.V.P. B			
									ALTURA DE CARGA EN METROS									MONOF.	TRIF.
									ASP.	IMP.	kW	Hp	3~400V	0	90				
NM80-160/110	100	80	11	15	21,8	27	27,3	26	24,5	22,5	16	-	1.844,00						
NM80-160/150	100	80	15	20	29,4	32,8	32,5	31,3	30,2	28,5	22,1	16,7	2.202,00						
NM80-160/185	100	80	18,5	25	35,5	39	38	36,8	36,7	33,8	28,8	23,5	2.651,00						
NM80-200/220	100	80	22	30	42,2	48	47,5	45,5	43,5	41	32,5	24,5	3.176,00						
NM80-200/300	100	80	30	40	56,9	60	59,5	58	57	54,5	47	40,5	3.966,00						
NM80-250/370	100	80	37	50	69,8	71,5	70,5	67,5	65,5	61,5	49,5	38,5	4.226,00						

DESCRIPCIÓN

- Electrobombas centrífugas monobloc de eje horizontal fabricadas **según norma EN 733**.
- Se utilizan en gran parte en alimentación hídrica, instalaciones de presurización y contra incendios, enfriamiento, calefacción, riego, aplicaciones agrícolas e industriales.
- Según el estándar se suministran con contrabrida y tornillería.



MATERIALES

- Cuerpo de bomba: **Fundición**
- Eje: **Acero INOX 304**
- Impulsores: **Fundición/Bronce (bajo demanda)**
- Cierre mecánico: **Cer/Graf**

ÁREA DE TRABAJO

- Temperatura máx. del líquido: **90°C**
- Temperatura mín. del líquido: **-10°C**
- Grado de protección: **IPX5**
- Aislamiento clase: **F**
- Presión máx. trabajo: **10 bar**



MODELO	DN Ø (mm)		P ₂		I (A)		CAUDAL											P.V.P.		A												
	ASP.	IMP.	kW	Hp	1~230V						3~400V					MONOF.	TRIF.															
	ALTURA DE CARGA EN METROS																															
CM 32-160C	50	32	1,5	2,0	9,3	3,6	0	6	7,5	9	12	15	18	21	24	27	30	33	23	22,8	22,5	22	21	19,2	16,9	14	1.119,00	1.107,00				
CM 32-160B	50	32	2,2	3,0	12,4	4,9	0	100	125	150	200	250	300	350	400	450	500	550	28	27,7	27,4	27	26,2	24,9	22,9	20,1	17	1.188,00	1.135,00			
CM 32-160A	50	32	3,0	4,0	-	6,8													36,1	36,2	36	35,6	34,6	33,2	31,4	28,9	25,7	22,1	-	1.195,00		
CM 32-200C	50	32	4,0	5,5	-	8,9													40,2	40,3	40,1	39,8	38,9	37,7	36,1	34,2	31,6	28,7	-	1.478,00		
CM 32-200B	50	32	5,5	7,5	-	11,1													48,3	48	47,9	47,6	46,7	45,5	44,2	42,6	40,5	37,9	35,4	-	1.959,00	
CM 32-200A	50	32	7,5	10	-	14,1													57,9	58,3	58,4	58,4	58	57,1	55,6	53,8	51,4	49,2	46,6	44,3	-	2.063,00
CM 32-250C	50	32	9,2	12,5	-	16,8													74,6	-	72,8	72,5	71,9	70,5	68,8	66,6	64,1	61,3	-	2.775,00		
CM 32-250B	50	32	11	15	-	20,0													84,8	-	84	83,9	83,6	82,7	81,1	78,6	75,4	73,2	-	2.918,00		
CM 32-250A	50	32	15	20	-	23,2													93,5	-	93,6	93,7	93,7	93,4	92,3	90,4	87,7	85,3	-	4.031,00		

Modelos monofásico con motor IE2.

MODELO	DN Ø (mm)		P ₂		I (A)		CAUDAL													P.V.P.		A												
	ASP.	IMP.	kW	Hp	1~230V						3~400V					MONOF.	TRIF.																	
	ALTURA DE CARGA EN METROS																																	
CM 40-125C	65	40	1,5	2,0	9,3	3,6	0	9	12	15	18	21	24	27	30	33	36	39	42	17,9	18,5	18,4	18,1	17,5	16,6	15,6	14,3	12,8	11,1	9,4	1.164,00	1.149,00		
CM 40-125B	65	40	2,2	3,0	12,4	4,9														22,6	23,4	23,3	23,1	22,7	22	21	19,9	18,6	17	15,1	13,2	1.250,00	1.175,00	
CM 40-125A	65	40	3,0	4,0	-	6,4														26,8	27,6	27,7	27,6	27,2	26,5	25,7	24,6	23,4	22	20,3	18,5	16,8	-	1.217,00
CM 40-160B	65	40	3,0	4,0	-	7,2														28,2	29,2	29,2	28,9	28,3	27,5	26,5	25,3	23,8	22,3	20,5	19,1	-	1.390,00	
CM 40-160A	65	40	4,0	5,5	-	9,2														33,8	34,9	34,8	34,5	33,9	33,2	32,4	31,3	30	28,5	26,9	25,2	23,4	-	1.437,00
CM 40-200B	65	40	5,5	7,5	-	12,7														44,6	45,5	45,4	45	44,5	43,5	42,3	41	39,3	37,2	34,9	32,3	29,4	-	1.964,00
CM 40-200A	65	40	7,5	10	-	16,5														56,2	56,5	56,5	56,3	55,9	55,1	54,1	52,8	51,2	49,3	47	44,4	41,6	-	2.071,00
CM 40-250C	65	40	9,2	12,5	-	20,2														64,8	64,4	64,2	63,8	63,4	62,7	61,9	61	59,8	57,9	55,4	-	2.800,00		
CM 40-250B	65	40	11	15	-	23,9														73,7	73,9	74,5	73,2	71,9	71,1	70,2	69,2	68,1	66,7	64,7	62,1	-	2.872,00	
CM 40-250A	65	40	15	20	-	31,3														82,6	84,6	84,8	84,7	84,3	83,4	82,4	81,3	80	78,5	76,9	75,4	72,8	-	3.995,00

Modelos monofásico con motor IE2.

MODELO	DN Ø (mm)	P ₂	I (A)	CAUDAL																	P.V.P.			
																					MONOF.	TRIF.		
				ASP.	IMP.	kW	Hp	1~230V	3~400V	ALTURA DE CARGA EN METROS														
				m ³ /h	0	12	21	24	27	30	33	36	39	42	48	54	60	66	72	78				
				l/min	0	200	350	400	450	500	550	600	650	700	800	900	1000	1100	1200	1300				
CM 50-125B	65	50	3,0	4,0	16,1	6,8	20	20,6	20,3	20,1	19,9	19,6	19,2	18,7	18,2	17,6	16,4	15	13,2	11,3	9,2	1.475,00	1.388,00	
CM 50-125A	65	50	4,0	5,5	22,5	8,8	23,7	24,3	24,1	23,9	23,7	23,3	23	22,6	22,1	21,7	20,7	19,6	18,2	16,4	14,2	1.761,00	1.435,00	
CM 50-160B	65	50	5,5	7,5	-	10,9	32,1	-	33,5	33,4	33,1	32,7	32,2	31,6	31	30,2	28,3	26,2	23,9	21,5	18,9	-	1.954,00	
CM 50-160A	65	50	7,5	10	-	14,4	38,1	-	39,8	39,8	39,7	39,5	39,2	38,8	38,3	37,7	36	34,2	32,2	29,7	27,4	25,4	-	2.057,00
CM 50-200C	65	50	9,2	12,5	-	17,2	48,2	-	-	49,7	49,2	48,5	47,7	46,9	45,9	44,9	42,6	40	36	32,3	28,9	-	2.651,00	
CM 50-200B	65	50	11	15	-	19,5	53,1	-	-	54,6	54,1	53,5	52,9	52,2	51,4	50,4	48,1	45,5	42,7	38,8	35	-	2.790,00	
CM 50-200A	65	50	15	20	-	24,7	59,9	-	-	61,8	61,5	61	60,4	59,7	58,8	58	56	53,6	50,8	47,8	44,4	39,8	-	3.929,00
CM 50-250C	65	50	15	20	-	28,6	69,2	-	-	68,2	67,7	67	66,3	65,6	64,7	62,8	59,9	56,2	52,1	-	4.047,00			
CM 50-250B	65	50	18,5	25	-	34,3	78,8	-	-	78,4	78	77,6	77	76,1	75,1	72,9	70,3	66,9	62,9	58,5	-	4.535,00		
CM 50-250A	65	50	22	30	-	40,9	88,5	-	-	88,3	88,1	87,7	87,2	86,6	85,8	83,8	81,4	78,5	75	70,2	64,8	-	4.791,00	

Modelos monofásico con motor IE2.

MODELO	DN Ø (mm)	P ₂	I (A)	CAUDAL																	P.V.P.	
																					TRIF.	
				ASP.	IMP.	kW	Hp	3~400V	ALTURA DE CARGA EN METROS													
				m ³ /h	0	30	36	42	48	54	60	66	72	78	84	96	108	120	132	144		
				l/min	0	500	600	700	800	900	1000	1100	1200	1300	1400	1600	1800	2000	2200	2400		
CM 65-125B	80	65	5,5	7,5	11,0	19,7	20,6	20,4	20,3	20,2	20	19,7	19,3	18,8	18,2	17,5	16,3	15	13,1	2.012,00		
CM 65-125A	80	65	7,5	10	14,4	24,6	25,2	25,1	25	24,9	24,7	24,5	24,2	23,9	23,5	23	22	20,6	18,8	16,8	2.118,00	
CM 65-160C	80	65	9,2	12,5	16,8	28,9	-	-	30,6	30,3	30	29,6	29,1	28,5	27,9	27,2	25,3	22,9	20,2	17,5	13,9	2.661,00
CM 65-160B	80	65	11	15	20,6	33,2	-	-	35,1	34,9	34,6	34,3	33,8	33,3	32,8	32,1	30,4	28,2	25,5	22,5	20,4	2.800,00
CM 65-160A	80	65	15	20	28,5	40,1	-	-	42,5	42,5	42,3	42,1	41,8	41,4	41	40,4	38,9	37,1	35,3	32,8	30,9	3.929,00
CM 65-200C	80	65	15	20	28,3	44,4	-	-	-	46,1	45,4	44,7	44	43,2	42,4	40,3	37,5	33,7	28,9	4.047,00		
CM 65-200B	80	65	18,5	25	34,8	51,7	-	-	-	53,9	53,4	52,7	52	51,3	50,4	48,6	45,9	43	39,4	34,6	4.529,00	
CM 65-200A	80	65	22,5	30	41,7	60,3	-	-	-	61,8	61,4	61	60,4	59,8	59,1	57,1	54,6	51,6	48,3	44,4	4.791,00	
CM 65-250B	80	65	30	40	55,3	80,6	-	-	-	80,6	79,5	78,4	77,1	75,7	74,1	70,4	66,1	61	54,7	47,3	8.539,00	
CM 65-250A	80	65	37	50	69,2	91,6	-	-	-	91,6	90,8	89,8	88,6	87,4	85,9	82,5	77,8	72,8	67,4	60,8	9.261,00	

MODELO	DN Ø (mm)	P ₂	I (A)	CAUDAL																	P.V.P.		
																					MONOF.	TRIF.	
				ASP.	IMP.	kW	Hp	3~400V	ALTURA DE CARGA EN METROS														
				m ³ /h	0	66	72	78	84	96	108	120	132	144	156	168	180	195	210	225			
				l/min	0	1100	1200	1300	1400	1600	1800	2000	2200	2400	2600	2800	3000	3250	3500	3750			
CM 80-160E	100	80	9,2	12,5	16,3	21,5	22,9	22,5	22,1	21,6	20,8	19,9	18,9	17,7	16,6	15,3	13,7	-	2.946,00				
CM 80-160D	100	80	11	15	20,0	25,4	27,3	27	26,6	26,3	25,4	24,5	23,5	22,4	21,2	19,9	18,3	16,4	-	2.946,00			
CM 80-160C	100	80	15	20	24,5	29	30,9	30,7	30,4	30,1	29,4	28,5	27,4	26,3	25,3	24,1	22,5	20,7	18,4	-	4.051,00		
CM 80-160B	100	80	18,5	25	30,3	33,6	35,9	35,7	35,4	35,2	34,5	33,7	32,9	32	31,1	30	28,6	27	24,5	22	-	4.537,00	
CM 80-160A	100	80	22,5	30	37,0	38	40,5	40,4	40,2	40,1	39,6	39,1	38,4	37,5	36,6	35,4	34,1	32,6	30,4	28,3	23,9	-	4.795,00

ELECTROBOMBA CENTRÍFUGA MONOBLOC NORMALIZADA INOX 304 SERIE CX

DESCRIPCIÓN

- Electrobombas centrífugas monobloc, adecuadas para bombeo de agua y líquidos limpios no agresivos.
- Ideal para circulación en instalaciones de climatización, sistemas de riego, presurización en aplicaciones industriales.



MATERIALES

- Hidráulica fabricada completamente en **Acero INOX 304**
- Cierre mecánico: **Graf/Cer**

ÁREA DE TRABAJO

- Temperatura máx. del líquido: **70°C**
- Grado de protección: **IP55**
- Aislamiento clase: **F**
- Presión máx. trabajo: **10 bar**
- Servicio continuo **S1**



IMPULSOR



DISPONIBLE EN
50Hz Y 60Hz



MONOBLOC NORMALIZADAS

CAUDAL								
m ³ /h	3	6	9	12,5	15	18	20	22
l/min	50	100	150	208	250	300	333	366

MODELO	DN Ø (mm)		P ₂		I (A)			PESO Kg	P.V.P.			SUPL. 60Hz						
	ASP.	IMP.	kW	Hp	1~230V	3~400V	MONOF.		TRIF.	60Hz								
CX 50-32-160/1.1	50	32	1,1	1,5	7,0	2,6	21,5	21	20	18,5	16,5	15	12,5	10	8	667,70	635,80	216,00
CX 50-32-160/1.5	50	32	1,5	2,0	9,2	3,5	22,5	26	24,5	22,5	20	18,5	15	12,5	9,5	718,30	663,30	223,00
CX 50-32-160/2.2	50	32	2,2	3,0	14,0	4,9	31,0	30,5	29,5	27,5	26	24	22,5	20,5	18	861,30	767,80	228,00
CX 50-32-200/3.0	50	32	3,0	4,0	-	6,3	34,0	40	37,5	35	33,5	31,5	30	26,5	25,5	-	982,30	219,00
CX 50-32-200/4.0	50	32	4,0	5,5	-	9,6	54,0	51,5	50	48	45	43	41	39	30	-	1.186,90	252,00
CX 50-32-200/5.5	50	32	5,5	7,5	-	11,1	53,0	65	61,2	58	55	51,4	46,5	42,5	40	-	1.265,00	284,00
CX 50-32-200/7.5	50	32	7,5	10	-	14,9	60,0	68	66	64	62,5	62	60	58	57	-	1.405,00	314,00

CAUDAL								
m ³ /h	5	10	15	20	25	30	35	40
l/min	83	167	250	333	417	500	583	667

MODELO	DN Ø (mm)		P ₂		I (A)			PESO Kg	P.V.P.			SUPL. 60Hz						
	ASP.	IMP.	kW	Hp	1~230V	3~400V	MONOF.		TRIF.	60Hz								
CX 65-40-125/1.5	65	40	1,5	2,0	9,2	3,5	21,0	20	19	17,5	16	13	10,5	-	-	721,60	666,60	214,00
CX 65-40-125/2.2	65	40	2,2	3,0	14,0	4,9	29,0	27	26	24	22	20	17	14	-	866,80	773,30	222,00
CX 65-40-125/3.0	65	40	3,0	4,0	-	6,3	37,0	31	30	29	27	25	22	18	-	-	893,20	225,00
CX 65-40-160/4.0	65	40	4,0	5,5	-	9,6	49,5	39	38	36,5	34	31	28	24	19	-	1.105,50	218,00
CX 65-40-200/5.5	65	40	5,5	7,5	-	11,1	62,5	47	46	45	44	41	38	34	30	-	1.303,50	252,00
CX 65-40-200/7.5	65	40	7,5	10	-	14,9	74,0	52	51,5	51	50	48	45	42	38	-	1.463,00	230,00
CX 65-40-200/11	65	40	11	15	-	21,2	93,0	69	69	68,5	68	68	66	64	60	-	1.857,90	267,00

CAUDAL								
m ³ /h	5	10	20	30	40	50	60	70
l/min	83	167	333	500	667	833	1000	1167

MODELO	DN Ø (mm)		P ₂		I (A)			PESO Kg	P.V.P.			SUPL. 60Hz						
	ASP.	IMP.	kW	Hp	3~400V	MONOF.	TRIF.		60Hz									
CX 65-50-125/3.0	65	50	3,0	4,0	6,3	37,5	27	26	23	20	16	10	-	-	903,10	218,00		
CX 65-50-125/4.0	65	50	4,0	5,5	9,6	49,5	28	27	26	24	21	16	-	-	1.113,20	222,00		
CX 65-50-160/5.5	65	50	5,5	7,5	11,1	62,5	34,5	34,5	34	31,5	28,5	24	20	-	-	1.326,60	232,00	
CX 65-50-200/7.5	65	50	7,5	10	14,9	73,0	41	41	40,5	39	36	32	27,5	-	-	1.488,30	238,00	
CX 65-50-200/9.2	65	50	9,2	12,5	18,3	82,0	52	52	51	49	45	41	37	-	-	1.700,60	253,00	
CX 65-50-200/11	65	50	11	15	21,2	93,0	57	56	55	53	51	48	42	30	-	-	1.864,50	257,00
CX 65-50-200/15	65	50	15	20	28,6	107,0	69	68	67	65	64	62	57	50	-	-	2.096,60	267,00
CX 65-50-200/18.5	65	50	18,5	25	34,7	158,0	73	72	71	70	69	68	65	59	-	-	2.867,70	252,00

ELECTROBOMBA CENTRÍFUGA MONOBLOC NORMALIZADA INOX 304 SERIE CX

MODELO	DN Ø (mm)		P ₂		I (A)		PESO		CAUDAL										P.V.P.		SUPL. 60Hz
	ASP.	IMP.	kW	Hp	3~400V	Kg	ALTURA DE CARGA EN METROS										MONOF.	TRIF.			
											40	50	60	70	80	90	100	110	120	130	
CX 80-65-125/4.0	80	65	4,0	5,5	9,6	49,5	19	18	17	15	13	11	9	-	1.268,30	216,00					
CX 80-65-125/5.5	80	65	5,5	7,5	11,1	62,5	22	21	20	19	18	17	15	13	10	-	1.400,30	220,00			
CX 80-65-125/7.5	80	65	7,5	10,0	14,9	69,5	27	26	25	24	23	22	20	18	15	-	1.574,10	212,00			
CX 80-65-125/9.2	80	65	9,2	12,5	18,3	80,5	30	29	29	28	27	26	25	23	22	19	-	1.809,50	230,00		
CX 80-65-160/11	80	65	11,0	15,0	21,2	93,0	36	35	34	33	32	31	29	27	25	22	-	2.051,50	237,00		
CX 80-65-160/15	80	65	15,0	20,0	28,6	107,0	44	43	42	40	39	38	37	36	34	32	-	2.300,10	245,00		
CX 80-65-200/18.5	80	65	18,5	25,0	34,7	158,0	53	52	51	50	49	48	47	45	44	41	-	2.986,50	282,00		
CX 80-65-200/22	80	65	22,0	30,0	41,1	192,0	60	59	58	57	56	55	54	53	51	49	-	3.543,10	292,00		
CX 80-65-200/30	80	65	30,0	40,0	55,7	223,0	72	72	71	70	69	68	67	66	65	63	-	4.458,30	277,00		

MODELO	DN Ø (mm)		P ₂		I (A)		PESO		CAUDAL										P.V.P.		SUPL. 60Hz
	ASP.	IMP.	kW	Hp	3~400V	Kg	ALTURA DE CARGA EN METROS										MONOF.	TRIF.			
											60	80	100	120	140	160	180	192	200		
CX 100-80-160/11	100	80	11,0	15,0	21,2	92,5	26	25	23	22	20	17	14	11	-	2.090,00	233,00				
CX 100-80-160/15	100	80	15,0	20,0	28,6	106,0	35	33	31	29	27	24	21	20	18	-	2.343,00	242,00			
CX 100-80-160/18,5	100	80	18,5	25,0	34,7	158,0	38	37	36	35	33	30	27	25	22	-	2.993,10	229,00			
CX 100-80-200/22	100	80	22,0	30,0	41,1	193,0	46	44	42	40	38	35	31	29	26	-	3.644,30	280,00			
CX 100-80-200/30	100	80	30,0	40,0	55,7	232,0	57	56	55	53	50	47	44	42	39	-	4.559,50	295,00			
CX 100-80-200/37	100	80	37,0	50,0	63,8	256,0	66	65	63	61	59	56	53	51	48	-	4.890,60	300,00			

DESCUBRE LA SERIE CX TAMBIÉN EN
ACERO INOX 316L



MONOBLOC | NORMALIZADAS

ELECTROBOMBA CENTRÍFUGA MONOBLOC NORMALIZADA INOX 316L SERIE CX

DESCRIPCIÓN

- Electrobombas centrífugas monobloc, adecuadas para bombeo de agua y líquidos limpios, no agresivos.
- Circulación en instalaciones de climatización, sistemas de riego, presurización en aplicaciones industriales.



MATERIALES

- Hidráulica fabricada completamente en **Acero INOX 316L**
- Cierre mecánico: **Graf/Cer**

ÁREA DE TRABAJO

- Mismos al modelo CX INOX 304 (ver pág. 184)



MODELO	DN Ø (mm)		P ₂	I (A)	PESO	CAUDAL								P.V.P. B	
	ASP.	IMP.				m ³ /h	l/min	3	6	9	12,5	15	18		20
	ASP.	IMP.	kW	Hp	3~400V	Kg	ALTURA DE CARGA EN METROS								TRIF.
CX 50-32-160/1.1	50	32	1,1	1,5	2,6	21,5	21	20	18,5	16,5	15	12,5	10	8	758,00
CX 50-32-160/1.5	50	32	1,5	2,0	3,5	22,5	26	24,5	22,5	20	18,5	15	12,5	9,5	786,00
CX 50-32-160/2.2	50	32	2,2	3,0	4,9	31	30,5	29,5	27,5	26	24	22,5	20,5	18	885,00
CX 50-32-200/3.0	50	21	3,0	4,0	6,3	34	40	37,5	35	33,5	31,5	30	26,5	25,5	1.167,00
CX 50-32-200/4.0	50	32	4,0	5,5	9,6	54	51,5	50	48	45	43	41	39	30	1.380,00

MODELO	DN Ø (mm)		P ₂	I (A)	PESO	CAUDAL								P.V.P. B	
	ASP.	IMP.				m ³ /h	l/min	5	10	15	20	25	30		35
	ASP.	IMP.	kW	Hp	3~400V	Kg	ALTURA DE CARGA EN METROS								TRIF.
CX 65-40-125/1.5	65	40	1,5	2,0	3,5	21	20	19	17,5	16	13	10,5			800,00
CX 65-40-125/2.2	65	40	2,2	3,0	4,9	29	27	26	24	22	20	17	14		902,00
CX 65-40-125/3.0	65	40	3,0	4,0	6,3	37	31	30	29	27	25	22	18		1.060,00
CX 65-40-160/4.0	65	40	4,0	5,5	9,6	49,5	39	38	36,5	34	31	28	24	19	1.281,00
CX 65-40-200/5.5	65	40	5,5	7,5	11,1	62,5	47	46	45	44	41	38	34	30	1.512,00
CX 65-40-200/7.5	65	40	7,5	10	14,9	74,0	52	51,5	51	50	48	45	42	38	1.697,00

MODELO	DN Ø (mm)		P ₂	I (A)	PESO	CAUDAL								P.V.P. B	
	ASP.	IMP.				m ³ /h	l/min	5	10	20	30	40	50		60
	ASP.	IMP.	kW	Hp	3~400V	Kg	ALTURA DE CARGA EN METROS								TRIF.
CX 65-50-125/3.0	65	50	3,0	4,0	6,3	37,5	27	26	23	20	16	10			1.048,00
CX 65-50-125/4.0	65	50	4,0	5,5	9,6	49,5	28	27	26	24	21	16			1.291,00
CX 65-50-160/5.5	65	50	5,5	7,5	11,1	62,5	34,5	34,5	34	31,5	28,5	24	20		1.539,00
CX 65-50-200/7.5	65	50	7,5	10	14,9	73	41	41	40,5	39	36	32	27,5		1.726,00

MODELO	DN Ø (mm)		P ₂	I (A)	PESO	CAUDAL										P.V.P. B
	ASP.	IMP.				m ³ /h	l/min	40	50	60	70	80	90	100	110	
	ASP.	IMP.	kW	Hp	3~400V	Kg	ALTURA DE CARGA EN METROS									
CX 80-65-125/4.0	80	65	4,0	5,5	9,6	49,5	19	18	17	15	13	11	9			1.471,00
CX 80-65-125/5.5	80	65	5,5	7,5	11,1	62,5	22	21	20	19	18	17	15	13	10	1.624,00
CX 80-65-125/7.5	80	65	7,5	10	14,9	69,5	27	26	25	24	23	22	20	18	15	1.826,00



EJE LIBRE NORMALIZADAS



DESCRIPCIÓN

- Cuerpo hidráulico monoetapa.
- Conexiones y dimensiones principales según **DIN 24255/EN 733**.
- El diseño de la bomba permite el completo desmontaje de la unidad rotórica sin desmontar la hidráulica de la tubería.

MATERIALES

- Cuerpo de bomba: **Fundición**
- Eje: **Acero INOX**
- Soporte: **Fundición**
- Acoplamiento: **Fundición**

ÁREA DE TRABAJO

- Temperatura máx. del líquido: **105°C**
- Altura máx.: **100 m**
- Presión máx. trabajo: **10 bar**



IMPULSOR EN INOX



DISPONIBLE EN
50Hz Y 60Hz

NORMALIZADAS

EJE LIBRE

CÁMARA PARTIDA

BOMBA A EJE LIBRE									
MODELO	DN		P.V.P.		MODELO	DN		P.V.P.	
	IMP.	ASP.	Cierre mecánico	Empaq.		IMP.	ASP.	Cierre mecánico	Empaq.
NW 32-125	32	50	529,00	523,00	NW 80-320	80	100	1.486,00	1.471,00
NW 32-160	32	50	572,00	566,00	NW 80-320G	80	100	1.725,00	1.708,00
NW 32-200	32	50	702,00	695,00	NW 80-400	80	100	2.142,00	2.121,00
NW 32-250	32	50	845,00	837,00	NW 100-160	100	125	1.082,00	1.071,00
NW 40-125	40	65	529,00	523,00	NW 100-200	100	125	1.117,00	1.106,00
NW 40-160	40	65	591,00	586,00	NW 100-250	100	125	1.341,00	1.328,00
NW 40-200	40	65	730,00	723,00	NW 100-315	100	125	1.623,00	1.607,00
NW 40-250	40	65	838,00	829,00	NW 100-315G	100	125	2.168,00	2.150,00
NW 40-315	40	65	1.256,00	1.243,00	NW 100-400	100	125	2.245,00	2.223,00
NW 40-320G	40	65	1.512,00	1.497,00	NW 125-200	125	150	1.322,00	1.309,00
NW 50-125	50	65	569,00	563,00	NW 125-250	125	150	1.425,00	1.411,00
NW 50-160	50	65	615,00	609,00	NW 125-250G	125	150	1.805,00	1.789,00
NW 50-200	50	65	734,00	727,00	NW 125-315	125	150	1.998,00	1.978,00
NW 50-250	50	65	900,00	891,00	NW 125-400	125	150	2.610,00	2.583,00
NW 50-250G	50	65	1.022,00	1.012,00	NW 125-500	125	150	4.907,00	4.858,00
NW 50-315	50	65	1.320,00	1.307,00	NW 150-200	150	200	1.521,00	1.505,00
NW 50-320G	50	65	1.617,00	1.600,00	NW 150-250	150	200	2.118,00	2.097,00
NW 65-125	65	80	626,00	620,00	NW 150-315	150	200	2.209,00	2.187,00
NW 65-160	65	80	665,00	658,00	NW 150-400	150	200	2.749,00	2.721,00
NW 65-200	65	80	792,00	785,00	NW 150-500	150	200	5.083,00	5.032,00
NW 65-200G	65	80	897,00	888,00	NW 200-260	200	250	2.811,00	2.783,00
NW 65-250	65	80	1.190,00	1.178,00	NW 200-320	200	250	3.734,00	3.697,00
NW 65-315	65	80	1.423,00	1.409,00	NW 200-400	200	250	4.441,00	4.397,00
NW 65-320G	65	80	1.705,00	1.688,00	NW 200-500	200	250	6.316,00	6.253,00
NW 80-160	80	100	747,00	739,00	NW 250-320	250	300	4.272,00	4.229,00
NW 80-200	80	100	1.003,00	993,00	NW 250-400	250	300	5.001,00	4.951,00
NW 80-250	80	100	1.150,00	1.139,00	NW 250-500	250	300	7.315,00	7.242,00
					NW 300-400	250	300	7.401,00	7.327,00

MONTAJE SOBRE BANCADA		
POTENCIA MOTOR HP	MONTAJE * 1500 rpm 3000 rpm	
	0,25	795,80
0,33	818,20	-
0,5	829,50	-
0,75	870,10	-
1	889,30	863,40
1,5	955,30	878,70
2	989,80	933,90
3	1.124,60	968,00
4	1.444,60	1.344,50
5,5	1.665,40	1.441,10
7,5	1.922,10	1.838,80
10	2.036,50	1.888,40
15	2.817,40	2.706,80
20	3.091,90	2.838,50
25	3.480,00	3.153,20
30	3.600,50	3.558,50
40	4.624,70	4.255,80
50	5.508,80	4.793,90
60	5.885,70	5.480,90
75	6.308,80	6.417,70
100	8.050,80	7.821,80
125	8.794,00	8.574,20
150	-	12.379,60
180	-	12.950,80
220	-	13.312,30
270	-	14.842,40

Recorte de impulsor: 60,00 € P.V.P. neto.

(*) El montaje sobre bancada incluye:

Motor, bancada, acoplamiento, protector de acoplamiento y montaje con la bomba.

No se incluye PVP de la bomba.

HIDRÁULICA CENTRÍFUGA ESTÁNDAR ISO 2858 SERIE CBS

DESCRIPCIÓN

- Cuerpo hidráulico adecuado para el abastecimiento de agua y drenaje, climatización y torre de enfriamiento, protección y extinción de incendios, para la marina (lastre y sentina), grupos de presurización, riego y agricultura.



MATERIALES

- Carcasa: **Fundición**
- Eje: **ASTM1045 (estándar)**
- Impulsor: **Bronce/Fundición o Acero INOX (opcional)**



ÁREA DE TRABAJO

- DN32-200mm**
- Rango altura: **2-160 m**
 - Rango caudal: **4-1000 m³/h**
 - Temperatura media:
Estándar: **15-90°**
Bajo pedido especial: **80-145°**
 - Presión de trabajo:
Estándar: **≤1.6MPa bar**
Bajo pedido: **≤2.4MPa**

MODELO	P.V.P.
CBS 50-32-160	
CBS 50-32-200	
CBS 65-40-200	
CBS 65-40-250	
CBS 65-40-315	
CBS 65-50-160	
CBS 80-50-200	
CBS 80-50-250	
CBS 80-50-315	
CBS 80-65-160	
CBS 100-65-200	
CBS 100-65-250	
CBS 100-65-315	
CBS 100-80-160	
CBS 125-80-200	
CBS 125-80-250	
CBS 125-80-315	
CBS 125-80-400	
CBS 125-100-200	
CBS 125-100-250	
CBS 125-100-315	
CBS 125-100-400	
CBS 125-100-500	
CBS 150-125-250	
CBS 150-125-315	
CBS 150-125-400	
CBS 150-125-500	
CBS 200-150-315	
CBS 200-150-400	
CBS 200-150-500	
CBS 250-200-315	

D

Consulte precios con nuestro dpto. comercial

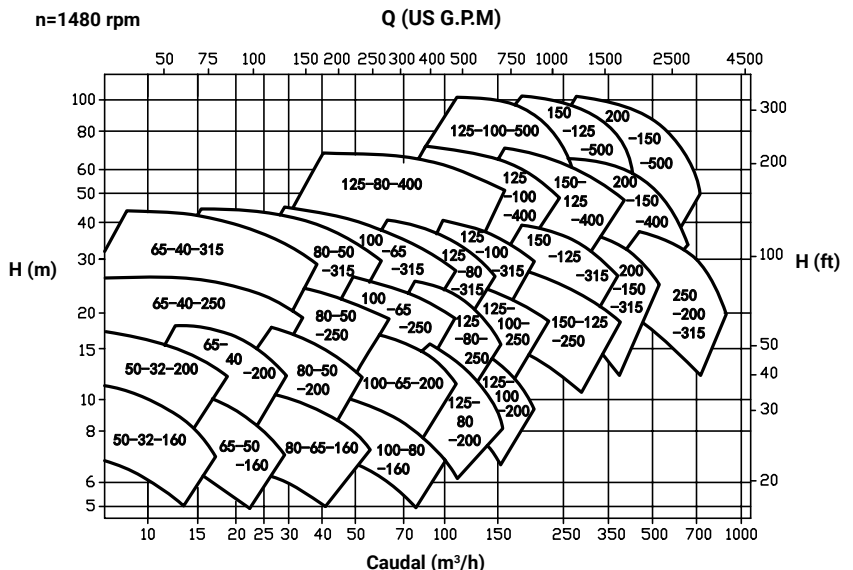
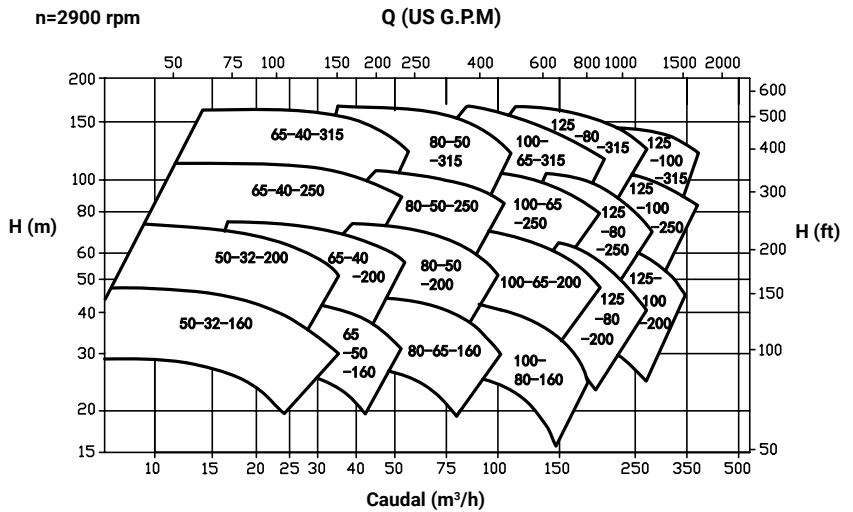

BOMBA DE CÁMARA PARTIDA SERIE BCP

DESCRIPCIÓN

- Los juegos completos de bomba de carcasa dividida tienen un diseño de doble aspiración, lo que garantiza una alta eficiencia y durabilidad.
- Las bombas de succión doble tienen una amplia gama de aplicaciones con caudales medios a altos, que ofrecen un rendimiento superior tanto en eficiencia como en mantenimiento.



MATERIALES

- Carcasa: **Fundición**
- Eje: **ASTM1045 (estándar)**
- Impulsor: **Bronce/Fundición o Acero INOX (opcional)**

ÁREA DE TRABAJO

- Temperatura máx. del líquido: **105°C**
- Altura máx.: **170 m**
- Presión máx. trabajo: **25 bar**

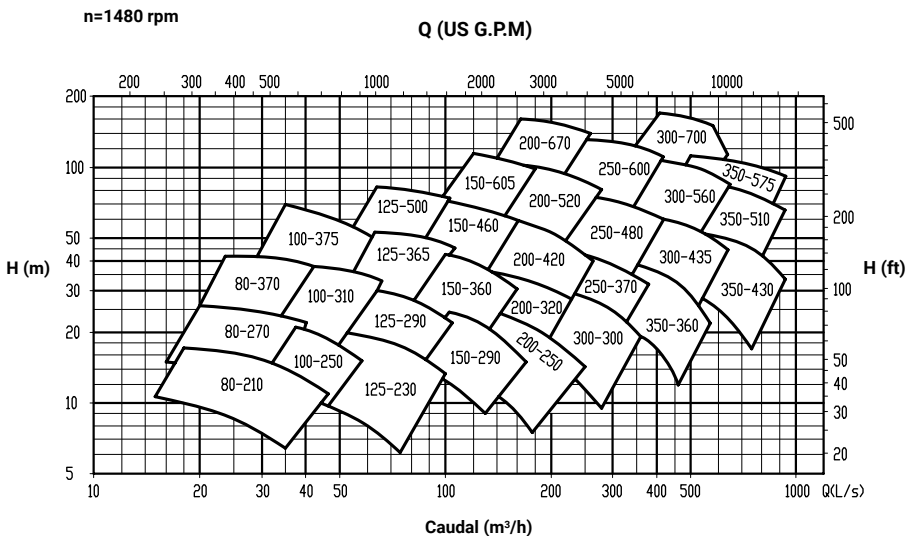
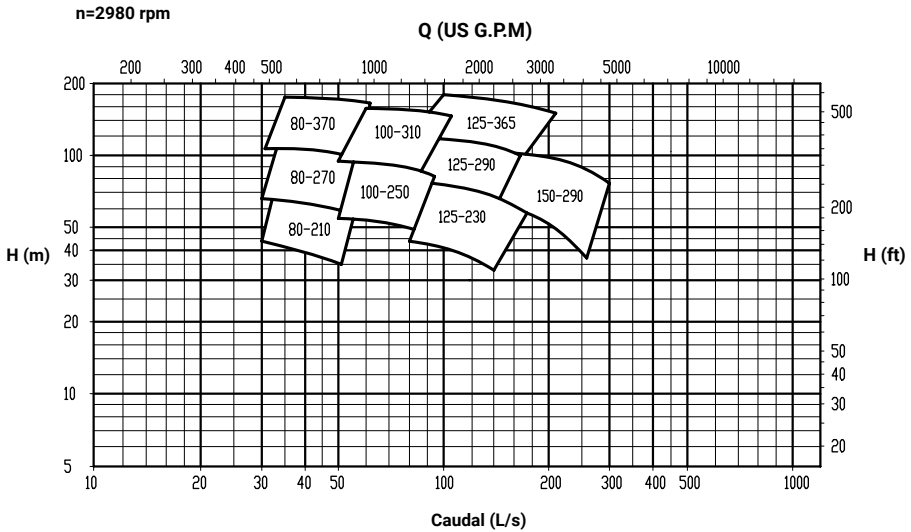

ELECTROBOMBAS EJE LIBRE MULTITAPA

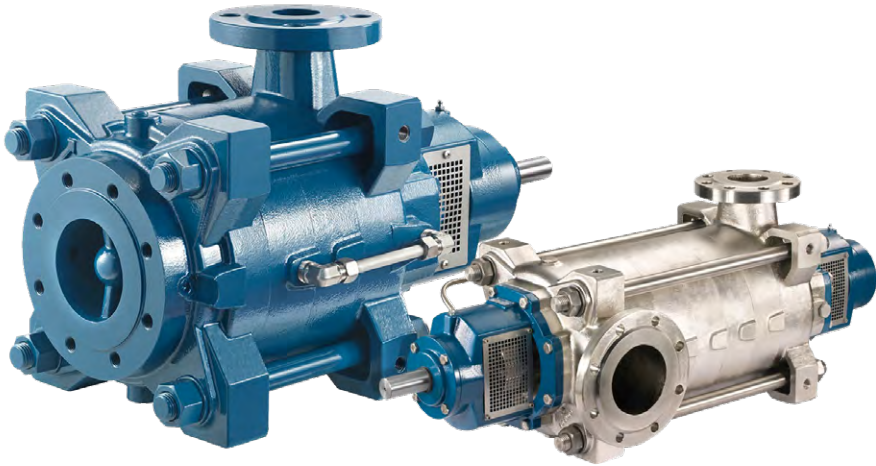

DESCRIPCIÓN

- Electrobombas centrífugas multitapa de **sección radial**, lo que permite su funcionamiento para instalaciones horizontales y/o verticales.
- Las bridas de las bocas de aspiración y descarga son conformes a las **normas EN o ANSI**, estas bocas pueden funcionar radialmente y se pueden girar 90°.
- La gran variedad de materiales, los distintos tipos de sellado en el eje y las diversas soluciones de lubricación para los cojinetes de la bomba, hacen que esta línea sea muy versátil e ideal para muchos usos en los campos industrial, energético y de tratamiento de aguas.
- Diseñadas para funcionar en condiciones de servicio pesado y con presiones muy elevadas (hasta 100 Bar) y temperaturas de hasta 180°C.



GRANDES CAUDALES

Hasta 1.200 m³/h



ALTAS PRESIONES

Hasta 1.000 m



DISEÑO DE SECCIÓN DE DISCO

Mejor eficiencia y ensamblaje



Consulte al comercial de su zona o con el dpto. Técnico para presupuestos en menos de 24 h.

MOTORES ELÉCTRICOS HORIZONTALES

DESCRIPCIÓN

- Los motores eléctricos horizontales están diseñados para su **integración en bombas de eje libre**, ofreciendo un rendimiento fiable y eficiente en aplicaciones de bombeo.
- Disponibles en un rango de **potencias desde 1,0 hasta 270 HP**.
- Configuración en **ejecución B3** (montaje con pies)
- Ideales para su uso en sistemas de abastecimiento de agua, riego agrícola, industria y tratamiento de aguas



MATERIALES

- Cuerpo motor: **≤ 10 Hp aluminio**
> 10 Hp fundición



ÁREA DE TRABAJO

- Trabajo horizontal
- Protección: **IP55**

MODELO	POTENCIA		EFICIENCIA	P.V.P		C
	KW	HP		1450 rpm	2900 rpm	
MOTOR/1	0,75	1,0	IE3	213,00	189,00	
MOTOR/1.5	1,1	1,5	IE3	249,00	204,00	
MOTOR/2	1,5	2,0	IE3	284,00	258,00	
MOTOR/3	2,2	3,0	IE3	388,00	293,00	
MOTOR/4	3,0	4,0	IE3	433,00	394,00	
MOTOR/5.5	4,0	5,5	IE3	567,00	491,00	
MOTOR/7.5	5,5	7,5	IE3	733,00	742,00	
MOTOR/10	7,5	10	IE3	848,00	792,00	
MOTOR/15	11	15	IE3	1.256,00	1.246,00	
MOTOR/20	15	20	IE3	1.427,00	1.376,00	
MOTOR/25	18,5	25	IE3	1.804,00	1.571,00	

MODELO	POTENCIA		EFICIENCIA	P.V.P		C
	KW	HP		1450 rpm	2900 rpm	
MOTOR/30	22	30	IE3	1.925,00	1.964,00	
MOTOR/40	30	40	IE3	2.595,00	2.513,00	
MOTOR/50	37	50	IE3	3.203,00	2.777,00	
MOTOR/60	45	60	IE3	3.583,00	3.470,00	
MOTOR/75	55	75	IE3	4.441,00	4.334,00	
MOTOR/100	75	100	IE3	5.581,00	5.360,00	
MOTOR/125	90	125	IE3	6.330,00	6.144,00	
MOTOR/150	110	150	IE3	9.283,00	9.956,00	
MOTOR/180	132	180	IE3	10.397,00	10.504,00	
MOTOR/220	160	220	IE3	11.568,00	10.893,00	
MOTOR/270	200	270	IE3	12.722,00	12.461,00	

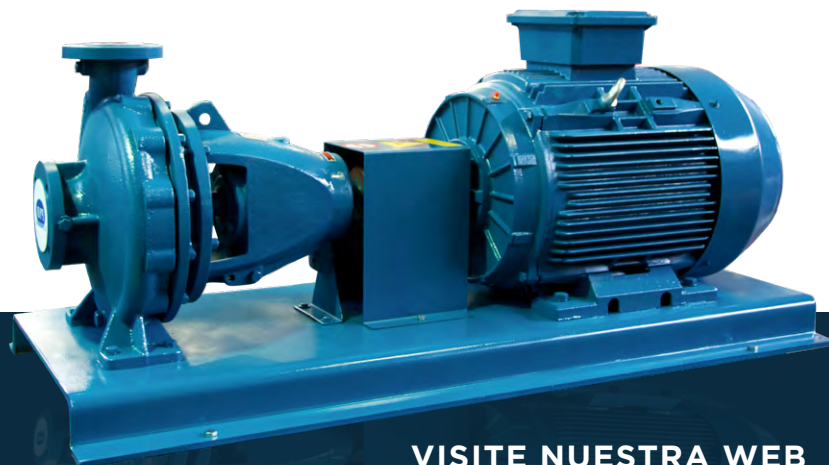

VISITE NUESTRA WEB
PARA OBTENER MÁS
INFORMACIÓN TÉCNICA



Capture el **código QR** para acceder a nuestra web.



CIRCULADORAS CALEFACCIÓN / ACS



PYD
ELECTROBOMBAS

ELECTROBOMBAS CIRCULADORAS SERIE PC

DESCRIPCIÓN

- Electrobombas in-line roscadas con ajuste de tres velocidades para circulación de fluido en sistemas de calefacción y aire acondicionado.

MATERIALES

- Cuerpo de bomba: **Fundición**



ÁREA DE TRABAJO

- Temperatura máx. del líquido: **110°C**
- Grado de protección: **IP44**
- Aislamiento clase: **H**
- Presión máx. trabajo: **10 bar**
- Fluidos limpios, libres de sólidos y aceites minerales, atóxicos y químicamente neutros.



RACORES

MODELO	DN mm	VELOC. Nº	P ₁ W	I A	CAUDAL												P.V.P. B	
					ALTURA DE CARGA EN METROS													
					0	0,5	1	1,5	2	2,5	3	4	5	6	8	10		
					m ³ /h	0	0,5	1	1,5	2	2,5	3	4	5	6	8	10	
					l/min	0	8,3	16,7	25	33,3	41,7	50	66,7	83,3	100	133,3	166,7	
						MONOF.												
PC15-4-130	15	1	30	0,13	2,4	1,6	0,9	0,4										
		2	45	0,20	3,4	2,8	2,2	1,5	0,8									94,00
		3	60	0,26	4	3,5	3,1	2,5	1,9	1,3	0,6							
PC15-6-130	15	1	45	0,20	3,2	2,2	1,5	0,8	0,4									
		2	65	0,30	5,1	4,1	3,3	2,5	1,8	1,1	0,6							102,00
		3	90	0,40	6	5,4	4,9	4,3	3,7	3,0	2,4	1						
PC20-4-130	20	1	60	0,13	2,4	1,6	0,9	0,4										
		2	45	0,20	3,4	2,8	2,2	1,5	0,8									102,00
		3	90	0,26	4	3,5	3,1	2,5	1,9	1,3	0,6							
PC20-6-130	20	1	45	0,20	3,2	2,2	1,5	0,8	0,4									
		2	65	0,30	5,1	4,1	3,3	2,5	1,8	1,1	0,6							109,00
		3	90	0,40	6	5,4	4,9	4,3	3,7	3	2,4	1						
PC25-4-130	25	1	30	0,13	2,4	1,6	0,9	0,4										
		2	45	0,20	3,4	2,8	2,2	1,5	0,8									102,00
		3	60	0,26	4	3,5	3,1	2,5	1,9	1,3	0,6							
PC25-6-130	25	1	45	0,20	3,2	2,2	1,5	0,8	0,4									
		2	65	0,30	5,1	4,1	3,3	2,5	1,8	1,1	0,6							109,00
		3	90	0,40	6	5,4	4,9	4,3	3,7	3	2,4	1						
PC25-4-180	25	1	30	0,13	2,4	1,6	0,9	0,4										
		2	45	0,20	3,4	2,8	2,2	1,5	0,8									102,00
		3	60	0,26	4	3,5	3,1	2,5	1,9	1,3	0,6							
PC25-6-180	25	1	45	0,20	3,2	2,2	1,5	0,8	0,4									
		2	65	0,30	5,1	4,1	3,3	2,5	1,8	1,1	0,6							106,00
		3	90	0,40	6	5,4	4,9	4,3	3,7	3	2,4	1						
PC32-6-180	32	1	45	0,20	3,2	2,2	1,5	0,8	0,4									
		2	65	0,30	5,1	4,1	3,3	2,5	1,8	1,1	0,6							114,00
		3	90	0,40	6	5,4	4,9	4,3	3,7	3	2,4	1						
PC32-8-180	32	1	140	0,63	5	4	3,2	2,4	1,8	1,3	1							
		2	210	0,92	7,5	6,8	6,2	5,5	4,9	4,3	3,8	2,8	1,9	1,2				168,00
		3	245	1,04	8	7,7	7,4	7	6,8	6,4	6,1	5,5	4,8	4,2	2,9	1,6		

ELECTROBOMBAS CIRCULADORAS SERIE PCB



DESCRIPCIÓN

- Electrobombas de circulación ACS (Agua Caliente Sanitaria) con **ajuste de tres velocidades**.

MATERIALES

- Cuerpo de bomba: **Bronce / INOX 304**



ÁREA DE TRABAJO

- Mismas a la Serie PC (pág 194)



RACORES EN BRONCE



MODELO	DN mm	VELOC. Nº	P ₁ W	I A	CAUDAL										P.V.P. B				
					m ³ /h	0	0,5	1	1,5	2	2,5	3	3,5	4		l/min	0	8,3	16,7
PCB20-4-130	20	1	30	0,13	ALTA DE CARGA EN METROS										MONOF. 158,00				
		2	45	0,20	2,4	1,6	0,9	0,4											
		3	60	0,26	3,4	2,8	2,2	1,5	0,8										
PCB20-6-130	20	1	45	0,20	2,4	1,6	0,9	0,4							161,00				
		2	65	0,30	3,2	2,2	1,5	0,8	0,4										
		3	90	0,40	5,1	4,1	3,3	2,5	1,8	1,1	0,6								
PCB20-12-180	20	1	140	0,63	7	4,4	2,4	1							243,00				
		2	210	0,92	10,8	9	7	5,1	3,1	1,3									
		3	245	1,04	12	11,3	10,3	9,1	7,8	6,3	4,7	2,9							
PCB25-4-130	25	1	30	0,13	2,4	1,6	0,9	0,4							172,00				
		2	45	0,20	3,4	2,8	2,2	1,5	0,8										
		3	60	0,26	4	3,5	3,1	2,5	1,9	1,3	0,6								
PCB25-6-130	25	1	45	0,20	3,2	2,2	1,5	0,8	0,4							176,00			
		2	65	0,30	5,1	4,1	3,3	2,5	1,8	1,1	0,6								
		3	90	0,40	6	5,4	4,9	4,3	3,7	3	2,4	1,7	1						
PCB25-4-180	25	1	30	0,13	2,4	1,6	0,9	0,4							174,00				
		2	45	0,20	3,4	2,8	2,2	1,5	0,8										
		3	60	0,26	4	3,5	3,1	2,5	1,9	1,3	0,6								
PCB25-6-180	25	1	45	0,20	3,2	2,2	1,5	0,8	0,4							179,00			
		2	65	0,30	5,1	4,1	3,3	2,5	1,8	1,1	0,6								
		3	90	0,40	6	5,4	4,9	4,3	3,7	3,0	2,4	1,7	1						

CIRCULADORAS CON VARIADOR SERIE PCV

DESCRIPCIÓN

- Electrobombas in-line roscadas con variador de velocidad para circulación de fluido en sistemas de calefacción y de aire acondicionado.
- Permite **tres modos de trabajo**: Presión constante, velocidad constante o presión proporcional.

MATERIALES

- Cuerpo de bomba: **Fundicion**



ÁREA DE TRABAJO

- Mismas a la Serie PC (pág 194)



RACORES



MODELO	DN mm	P ₁ W	CAUDAL MÁXIMO															P.V.P. B													
			m ³ /h	0	0,2	0,4	0,6	0,8	1	1,2	1,4	1,6	1,8	2	2,2	2,4	2,6		2,8	l/min	0	3,3	6,7	10	13,3	16,7	20	23,3	26,7	30	33,3
PCV25-4-130	25	22	ALTA DE CARGA MÁXIMA EN METROS															MONOF. 208,00													
PCV25-4-180	25	22	4,2	4,1	3,7	3,4	3,2	2,7	2,5	2,2	1,8	1,6	1,3	1,1	0,8											208,00					
PCV25-6-130	25	45	6,2	6,1	6	5,9	5,6	5,1	4,6	4,2	3,8	3,4	3,1	2,7	2,4	2,1	1,8											227,00			
PCV25-6-180	25	45	6,2	6,1	6	5,9	5,6	5,1	4,6	4,2	3,8	3,4	3,1	2,7	2,4	2,1	1,8											227,00			
PCV32-6-180	32	45	6,2	6,1	6	5,9	5,6	5,1	4,6	4,2	3,8	3,4	3,1	2,7	2,4	2,1	1,8											227,00			

CIRCULADORA ELECTRÓNICA SERIE PA

DESCRIPCIÓN

- Electrobombas electrónicas para circulación de fluido en sistemas de calefacción y de aire acondicionado.
- Modo de velocidad constante.
- Bajo nivel de ruido.

MATERIALES

- Cuerpo de bomba: **Fundición**



ÁREA DE TRABAJO

- Temperatura máx. del líquido: **110°C**
- Grado de protección: **IP44**
- Aislamiento clase: **F**
- Presión máx. trabajo: **10 bar**
- Fluidos limpios, libres de sólidos y aceites minerales, atóxicos y químicamente neutros.



RACORES

		CAUDAL MÁXIMO													
m ³ /h	0	0,4	0,8	1,2	1,6	2	2,4	2,5	3	4	5	6	7	8	
l/min	0	6,7	13,3	20	26,7	33,3	40	41,7	50	66,7	83,3	100	116,7	133,3	

MODELO	DN	P ₁	ALTURA DE CARGA MÁXIMA EN METROS												P.V.P. B		
	mm	W	MONOF.														
PA20-4-130	20	22	4	3,8	3,3	2,7	2,2	1,4	1	0,9						169,50	
PA20-6-130	20	45	6	5,9	5,3	4,5	3,7	3	2,5	2,3	1,8						171,80
PA25-4-130	25	22	4	3,8	3,3	2,7	2,2	1,4	1	0,9						169,50	
PA25-6-130	25	45	6	5,9	5,3	4,5	3,7	3	2,5	2,3	1,8						171,80
PA25-4-180	25	22	4	3,8	3,3	2,7	2,2	1,4	1	0,9						169,50	
PA25-6-180	25	45	6	5,9	5,3	4,5	3,7	3	2,5	2,3	1,8						171,80
PA25-8-180	25	88	8	8	7,9	7,8	7,7	7,3	6,8	6,7	6,3	5,3	4,2	3,2	2,3	1,3	200,60
PA32-4-180	32	22	4	3,8	3,3	2,7	2,2	1,4	1	0,9						181,00	
PA32-6-180	32	45	6	5,9	5,3	4,5	3,7	3	2,5	2,3	1,8						191,00
PA32-8-180	32	88	8	8	7,9	7,8	7,7	7,3	6,8	6,7	6,3	5,3	4,2	3,2	2,3	1,3	203,70

NOMENCLATURA

PA 20 - 6 - 130

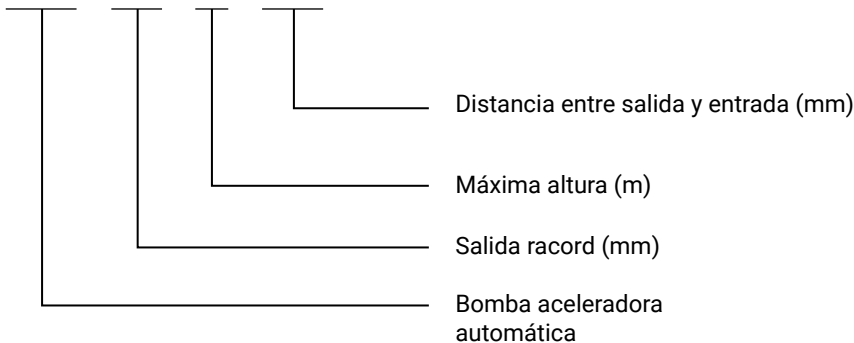



DEPÓSITOS Y VALVULERÍA



DEPÓSITOS DE MEMBRANA EPDM

DESCRIPCIÓN

- Depósitos de acero soldado con **membrana sustituible**, completamente impermeable, de **EPDM** en una sola pieza, manteniendo en permanente aislamiento al agua del aire, excluyendo así cualquier posibilidad de corrosión de la superficie metálica interior del depósito o dilución del aire en el agua.
- La estanqueidad y resistencia de los depósitos se comprueban a una presión 1,5 veces superior a la presión máxima de servicio.
- Todos los depósitos **a partir de 150 litros llevan un manómetro incorporado**.
- Precarga de aire: **4 bar**
- Disponibles en **PN10 y PN16**



MODELO	VOL. P. MÁX		TEMPERATURA DE TRABAJO	CONEXIÓN DE ENTRADA	DIMENSIONES		P.V.P.					
	L	bar			°C	Ø"	mm	mm	PN-10	PN-16	MEMBRANA PN10	MEMBRANA PN16
DEP 5/10	5	10/16	-10 ~+100	1/2	160	315	40,10	60,20	7,15	-		
DEP 25/10	25	10/16	-10 ~+100	1	270	470	65,80	98,60	10,90	16,40		
DEP 50/10 SP	50	10/16	-10 ~+100	1	470	620	129,10	193,70	25,20	37,70		
DEP 50/10 CPS	50	10/16	-10 ~+100	1	565 (L)	410	135,30	202,90	25,20	37,70		
DEP 100/10	100	10/16	-10 ~+100	1	470	920	263,90	395,90	57,10	81,90		
DEP 150/10	150	10/16	-10 ~+100	1	470	1.250	380,70	571,10	93,00	140,60		
DEP 200/10	200	10/16	-10 ~+100	1	600	1.080	518,90	778,30	93,00	140,60		
DEP 300/10	300	10/16	-10 ~+100	1 ½	640	1.245	639,70	959,52	127,70	191,60		
DEP 500/10	500	10/16	-10 ~+100	1 ½	750	1.550	933,30	1.399,90	309,80	372,40		
DEP 750/10	750	10/16	-10 ~+100	2	750	1.850	1.465,50	2.198,20	309,80	372,40		

Los modelos a partir de 100L (incluido) van en posición vertical y con patas. Modelo DEP50/10 CPS va en posición horizontal y con soporte.

DEPÓSITOS DE MEMBRANA FIJA DE BUTILO

DESCRIPCIÓN

- Depósitos fabricados con **membrana fija** de butilo.
- Con la ayuda de este diseño de tanque, **la calidad del agua no se verá contaminada** por la parte interna del cuerpo metálico y tampoco por los ambientes externos.
- Todos los tanques tienen conexión de acero inoxidable para proporcionar estándares higiénicos para el agua potable.



CONEXIÓN EN ACERO INOX



MODELO	VOL. P MÁX		DIMENSIONES		TEMPERATURA	POSICIÓN	CONEXIÓN	P.V.P.
	L	bar	Ø	H	MÁX	TRABAJO	DN	
8V-PW-FT	8	10	200	345	-10~+99	VERTICAL	1	72,20
19V-PW-FT	19	10	270	370	-10~+99	VERTICAL	1	86,90
24V-PW-FT	24	10	300	440	-10~+99	VERTICAL	1	95,40
50H-PW-FT	50	10	470	390	-10~+99	HORIZONTAL	1	228,30
50V-PW-FT	50	10	350	560	-10~+99	VERTICAL	1	211,30
80VL-PW-FT	80	10	425	625	-10~+99	VERTICAL	1	332,30
100VL-PW-FT	100	10	425	790	-10~+99	VERTICAL	1	402,60
150VL-PW-FT	150	10	450	810	-10~+99	VERTICAL	1	570,10

DEPÓSITOS DE MEMBRANA DE BUTILO

DESCRIPCIÓN

- Hidrosfera sanitaria apta para **aguas potables** (caliente o fría).
- Su instalación permite un ahorro de agua y prolonga la vida útil de los grupos protegiéndolos de la cal.
- **Capa interna fabricada en epoxi** que protege el contacto entre el agua y el acero evitando el crecimiento bacteriano.
- **Conformidad con la norma 2014/68/UE.**
- **Conexión de acero esmaltado.**



MODELO	VOL. P MÁX		DIMENSIONES		TEMPERATURA	POSICIÓN	CONEXIÓN	P.V.P.
	L	bar	Ø	H	MÁX	TRABAJO	DN	
			mm	mm	°C	TIPO	Ø"	
HYB8	8	10	200	326	-10~+99	Vertical	¾"	59,00
HYB18	18	10	270	395	-10~+99	Vertical	¾"	66,00
HYB24	24	10	300	436	-10~+99	Vertical	1"	66,00
HYB50V	50	10	380	523	-10~+99	Vertical	1"	213,00
HYB50H	50	10	380	543	-10~+99	Horizontal	1"	216,00
HYB80	80	10	450	626	-10~+99	Vertical	1"	326,00
HYB105	105	10	500	683	-10~+99	Vertical	1¼"	529,00
HYB150	150	10	500	915	-10~+99	Vertical	1¼"	595,00
HYB200	200	10	600	830	-10~+99	Vertical	1¼"	783,00
HYB250	250	10	630	975	-10~+99	Vertical	1¼"	846,00
HYB300	300	10	630	1123	-10~+99	Vertical	1¼"	1.015,00
HYB400	400	10	630	1495	-10~+99	Vertical	1¼"	1.347,00
HYB500	500	10	750	1385	-10~+99	Vertical	1¼"	1.510,00
HYB600	600	10	750	1505	-10~+99	Vertical	1¼"	1.942,00

KITS DE MONTAJE

DESCRIPCIÓN

- Kits de montaje para grupos hidroneumáticos domésticos.
- Se incluye montaje y ensamblaje, cable eléctrico y enchufe.
- **Sumar el precio del kit de presión a la bomba horizontal seleccionada para obtener el precio del grupo completo.**



MODELO	VOL. P MÁX		SUPLEMENTOS DE MONTAJE							P.V.P.
	L	bar	DEPÓSITO	PRESOST.	MANÓM.	RACORD	MALLA	LLAVE	VÁLVULA	
			MEMBRANA	ARRANQUE	SECO	5 VÍAS	FLEXIBLE	ESFERA	RETENCIÓN	
KIT PRESIÓN 25	25	8	DEP 25/8	PM5	5 bar	CORTO	-	-	-	135,00
KIT PRESIÓN 50	50	10	DEP 50/10	PM5	5 bar	CORTO	1x800	1"	1"	268,00

DEPÓSITOS GALVANIZADOS

DESCRIPCIÓN

- Depósitos fabricados en acero galvanizado, de acuerdo a la **Directiva 2014/68/UE** de equipos a presión, a partir de dos fondos embutidos y virola de chapa curvada, unidos entre sí mediante cordones de soldadura, realizados según procedimientos y personal homologado.
- La estanqueidad y resistencia de los depósitos se comprueban a una presión 1,5 veces superior a la presión máxima de servicio.
- La temperatura máx. de servicio es de **60°C**.



MODELO	VOL. L	P MÁX bar	PESO Kg	CONEXIONES		DIMENSIONES		P.V.P. C
				ENTRADA Ø"	INYECTOR Ø"	Ø mm	H mm	
GALV 500 /10	500	10	85,0	1 ½	1/2	650	1.860	2.155,60
GALV 750 /10	750	10	158,0	1 ½	1/2	750	2.080	3.168,00
GALV 1000 /10	1.000	10	227,0	1 ½	1/2	800	2.350	4.834,60
GALV 1250 /10	1.250	10	302,0	2	1 ½	900	2.300	6.633,80
GALV 1500 /10	1.500	10	343,0	2	1 ½	950	2.465	7.049,30
GALV 2000 /10	2.000	10	490,0	3	1 ½	1.100	2.490	9.899,40
GALV 2500 /10	2.500	10	555,0	3	1 ½	1.100	3.045	10.998,70

INYECTORES PARA DEPÓSITOS GALVANIZADOS

DESCRIPCIÓN

- Los inyectores de aire garantizan un suministro abundante y continuo de aire al depósito mediante el uso de **bombas centrífugas externas**. Su construcción es fuerte y compacta.
- El inyector debe ser instalado en vertical como se indica en el esquema. Una válvula de bola (V1) debe instalarse entre el depósito y el extremo superior del inyector. Una segunda válvula de bola (V2) debe instalarse entre el extremo inferior del inyector y el adaptador de succión de la bomba. **No debe instalarse ninguna otra válvula en la tubería que une la bomba y el depósito, o el inyector no funcionará.**
- Es necesario ajustar la válvula V2 en caso de altos niveles de presión, para evitar los ruidos y vibraciones producidos por el descenso rápido de la boya del inyector.
- En caso de que la bomba esté conectada a un suministro de agua, asegúrese de que la presión del depósito es al menos 1,7 veces la presión nominal.

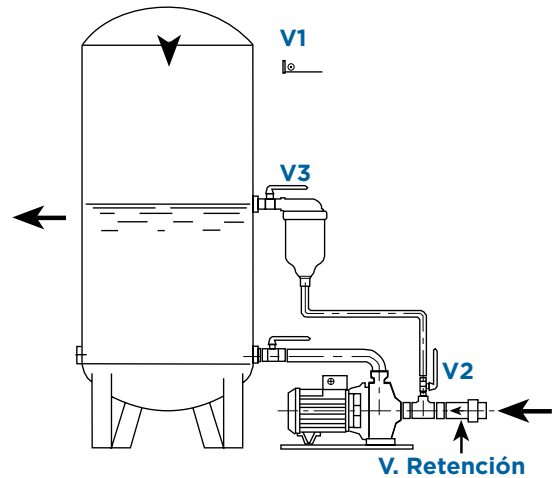

DESCRIPCIÓN

- Inyectores de aire para calderines galvanizados.
- Manguito flexible recubierto en acero galvanizado incluido; en series M y N conexiones 1/2" x 1 metro; en serie A conexiones 1" x 1 metro.

MATERIALES

- Cuerpo: **Resina sintética de alta resistencia**
- Tornillería: **Acero INOX**

ÁREA DE TRABAJO

- Temperatura máxima del líquido: **45°C**
- Servicio continuo



INYECTORES DE 100 A 6.000 LTS.

MODELO	SERIE	VOLUMEN L	P MÁX. bar	CONEXIONES		DIMENSIONES		P.V.P. A
				ENTRADA	SALIDA	D	H	
				Ø"	Ø"	mm	mm	
MINOR	M	100 - 200	8	1/2"	1/2"	86	162	81,60
NICK	N	24 - 750	8	1/2"	1/2"	112	220	75,50
MEDIO	M	300 - 750	8	1/2"	1/2"	86	230	97,70
MAIOR	M	1.000 - 1.500	8	1/2"	1/2"	86	370	147,20
LEON	N	1.000 - 2.000	8	1/2"	1/2"	112	320	90,90
RAN	A	500 - 750	10	1 1/2"	1"	156	290	165,40
AN	A	1.000 - 2.000	10	1 1/2"	1"	156	438	246,80
MAN	A	3.000 - 6.000	10	1 1/2"	1"	156	566	318,90

DESCRIPCIÓN

- Sistema de comprobación de nivel de agua del depósito galvanizado mediante tubo transparente, instalado entre grifos de nivel, haciendo la función de visor.
- El protector del tubo se instala en la parte trasera del visor a modo de espejo, facilitando la lectura del nivel.

MATERIALES

- Grifos de nivel fabricados en latón. Microtubo DN 16 en materiales plásticos, completamente transparente
- Protector en chapa galvanizada

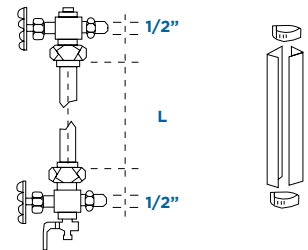

ÚTILES PARA LA INSTALACIÓN

MODELO	DEPÓSITO L	P MÁX. bar	CONEXIONES		DIMENSIONES		P.V.P. A
			ENTRADA	SALIDA	Ø	LONGITUD	
			Ø"	Ø"	mm	mm	
GRIFO NIVEL	100 - 6.000	10	1/2"	1/2"	-	-	80,00
MICROTUBO	100 - 6.000	10	-	-	16	0,5	10,00
PROTECTOR	100 - 6.000	10	-	-	20	0,5	28,00

VÁLVULAS ESFERA PASO TOTAL



DN(Ø")	DN Ø	P.V.P.	C
1/2	0,15	8,00	
3/4	0,25	12,00	
1	0,41	19,00	
1 ¼	0,61	29,00	
1 ½	0,83	41,00	
2	1,33	63,00	

VÁLVULAS ESFERA PORTAMANGUERA



DN(Ø")	DN Ø	P.V.P.	C
1/2	0,15	7,00	
3/4	0,20	10,00	
1	0,33	15,00	

FILTROS VÁLVULAS RETENCIÓN TIPO YORK



DN(Ø")	DN Ø	P.V.P.	C
1/2	0,01	1,00	
3/4	0,01	1,00	
1	0,03	2,00	
1 ¼	0,02	2,00	
1 ½	0,04	3,00	
2	0,06	4,00	
2 ½	0,08	6,00	
3	0,13	8,00	
4	0,19	12,00	

VÁLVULAS DE PIE TIPO YORK



DN(Ø")	DN Ø	P.V.P.	C
1/2	0,10	7,00	
3/4	0,14	10,00	
1	0,20	12,00	
1 ¼	0,28	17,00	
1 ½	0,43	26,00	
2	0,61	37,00	
2 ½	1,07	69,00	
3	1,65	97,00	
4	2,48	164,00	

VÁLVULAS DE COMPUERTA



DN(Ø")	DN Ø	P.V.P.	C
1/2	0,16	8,00	
3/4	0,21	10,00	
1	0,29	14,00	
1 ¼	0,44	21,00	
1 ½	0,60	29,00	
2	1,06	51,00	

FILTRO ANGULAR



DN(Ø")	DN Ø	P.V.P.	C
1/2	0,12	6,00	
3/4	0,18	9,00	
1	0,26	13,00	
1 ¼	0,57	26,00	
1 ½	0,78	35,00	
2	1,26	58,00	

VÁLVULAS DE ESFERA MANDO PALOMILLA



DN(Ø")	DN Ø	P.V.P.	C
1/2	0,14	7,00	
3/4	0,25	11,00	
1	0,36	16,00	

VÁLVULAS REDUCTORAS DE PRESIÓN



DN(Ø")	DN Ø	P.V.P.	C
1/2	0,54	46,00	
3/4	0,57	49,00	
1	1,14	124,00	
1 ¼	1,37	162,00	
1 ½	1,44	208,00	
2	1,53	268,00	

VÁLVULAS DE RETENCIÓN



DN(Ø")	DN Ø	P.V.P.	C
1/2	0,11	6,00	
3/4	0,18	9,00	
1	0,26	12,00	
1 ¼	0,38	17,00	
1 ½	0,51	25,00	
2	0,80	38,00	
2 ½	1,62	82,00	
3	2,35	118,00	
4	3,82	184,00	

VÁLVULAS DE RETENCIÓN TIPO YORK



DN(Ø")	DN Ø	P.V.P.	C
1/2	0,13	9,00	
3/4	0,25	14,00	
1	0,28	16,00	
1 ¼	0,39	24,00	
1 ½	0,61	39,00	
2	0,8	50,00	
2 ½	1,45	99,00	
3	2,11	143,00	
4	3,29	247,00	

VÁLVULAS DE SEGURIDAD



DN(Ø")	DN Ø	P.V.P.	C
1/2	0,34	44,00	
3/4	0,64	54,00	
1	1,03	72,00	
1 ¼	1,63	123,00	
1 ½	2,01	148,00	
2	2,87	231,00	

VÁLVULAS DE RET. CLAPETAS DE METAL



DN(Ø")	DN Ø	P.V.P.	C
1/2	0,15	9,00	
3/4	0,22	12,00	
1	0,33	18,00	
1 ¼	0,46	25,00	
1 ½	0,7	38,00	
2	1,05	53,00	
2 ½	1,59	77,00	
3	2,47	124,00	
4	3,80	205,00	

VÁLVULA RETENCIÓN AGUAS RESIDUALES

DN(mm)	P.V.P. F	
	ROSCA	BRIDA
32	58,60	-
40	65,90	-
50	86,60	83,00
65	124,50	105,10
80	161,50	112,30
100	-	167,60
125	-	269,50
150	-	352,10
200	-	732,20



VÁLVULA DE MARIPOSA GOLD PN 10/16

DN(mm)	P.V.P. F	
	PALANCA REDUCTOR	
50	31,80	68,70
65	37,30	73,80
80	40,40	75,50
100	55,20	84,30
125	75,10	94,90
150	95,10	114,50
200	130,70	169,70
250	212,50	236,90
300	297,10	335,70
400	-	811,80
500	-	1.323,40



VÁLVULA COMPUERTA EMBRIDADA PN 10/16

DN(mm)	P.V.P. F
50	141,70
65	178,60
80	214,70
100	295,00
125	377,10
150	522,40
200	788,60
250	1.204,50
300	2.226,80



VÁLVULA DE RETENCIÓN DE DOBLE DISCO

DN(mm)	P.V.P. F
50	36,10
65	43,30
80	53,20
100	63,20
125	89,30
150	118,20
200	194,00
250	323,00
300	415,00
400	832,80
500	1.430,00



VÁLVULA RETENCIÓN Y PIE DE DISCO AXIAL

DN(mm)	P.V.P. F	
	RETENC.	PIE
50	198,00	-
65	243,10	-
80	282,70	275,70
100	357,50	330,90
125	432,30	441,10
150	573,10	606,60
200	772,00	794,00
250	1.100,00	1.047,70



MANGUITOS ELÁSTICOS EMBRIDADOS

DN(mm)	P.V.P. F
50	38,80
65	46,00
80	57,70
100	68,60
125	96,50
150	129,90
200	193,10
250	282,40
300	342,90
350	468,30
400	582,90
500	889,60
600	1.136,80



FILTROS EN "Y" EMBRIDADOS

DN(mm)	P.V.P. F
50	58,60
65	80,30
80	92,00
100	120,00
125	186,80
150	246,30
200	411,40
250	783,20
300	1.169,30



BRIDA ROSCADA INOX 316 UNE-EN-1092-1

DN(mm)	PN	P.V.P. F
25	40	41,30
32	40	57,20
40	40	66,70
50	16	76,30
65	16	90,50
80	16	114,60
100	16	130,80



BRIDA ROSCADA ACERO AL CARBONO

DN(mm)	PN	P.V.P. F
25	16	14,80
32	16	15,50
40	16	16,20
50	16	16,50
65	16	21,00
80	16	25,60
100	16	31,50
125	16	36,20





CONTROLADORES DE PRESIÓN



kgf/cm² CL 1.0

CONTROLADORES DE PRESIÓN



DESCRIPCIÓN

- **Dispositivos compactos** para el control automático y protección de electrobombas.
- **Fáciles de instalar y ajustar**, permitiendo una configuración rápida y sin complicaciones para el usuario.
- Proporciona **control automático de la presión**, ajustándose de manera precisa a las necesidades del sistema.
- Optimiza el rendimiento de la bomba, asegura un funcionamiento continuo y eficiente durante largos periodos de tiempo.
- Disponen de un sistema de seguridad contra funcionamiento en seco. Funcionan arrancando la bomba automáticamente cuando se produce la apertura de cualquier grifo de la instalación. Cuando cesa el caudal la bomba se detiene.

TABLA COMPARATIVA

MODELO	I MÁX	P MÁX	FREC.	DN	PRESIÓN DE ARRANQUE	PRESIÓN PARADA	REGULABLE	MODO TEMPORIZADOR	PROTECCIÓN TRABAJO EN SECO	MANÓMETRO	TERMINALES	
	A	kW	Hp	Hz	mm	bar						bar
CONTROLPUMP	10	1,5	2,0	50 / 60	25	1,5	No	✗	✗	✓	✓	✗
ECO	10	1,5	2,0	50 / 60	25	1,5	No	✗	✗	✓	✗	✗
PYD-5	10	1,5	2,0	50 / 60	25	1,2 - 2,5	No	✓	✗	✓	✓	✓
PYD-5 ENCH	10	1,5	2,0	50 / 60	25	1,2 - 2,5	No	✓	✗	✓	✓	✗
PYD-15	10	1,5	2,0	50 / 60	25	1,2 - 2,5	No	✓	✓	✓	✓	✓
DIGI-PLUS	16	2,2	3,0	50 / 60	25	0,5 - 6,7	0,8 - 7,0	✓	✗	✓	✓	✓
EURO-2	10	1,5	2,0	50 / 60	25	1,2 - 2,5	No	✓	✗	✓	✓	✓
OPTIPLUS	16	2,2	3,0	50/60	32	1,5 - 2,5	No	✓	✗	✓	✓	✗

MONTAJE

Le podemos servir el controlador y la bomba montados y embalados, listos para su instalación tras la recepción.

El montaje incluye:

- Cable de conexión entre la bomba y el controlador
- Conexionado
- Embalaje

SERVICIO DE MONTAJE	P.V.P.	B
	30,00	

Bomba con controlador conexionado e instalado.

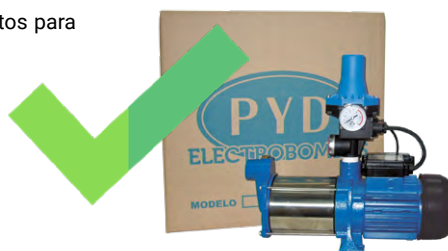

CONTROLADOR SERIE CONTROLPUMP

DESCRIPCIÓN

- Dispositivo compacto para el control automático y protección de electrobombas.
- Sistema patentado **dotado de sensores de caudal y presión integrados** en un circuito electrónico para controlar el funcionamiento de la electrobomba y mantener la presión y el caudal constante.
- Dispone de un **sistema de seguridad contra funcionamiento en seco** de la bomba.

CARACTERÍSTICAS

- **Cable a bomba:** 0,5 m
- **Cable a red:** 1,5 m con enchufe schuko
- **Potencia máx. bomba:** 1,5 kW
- **Protección:** IP54
- **Presión máxima:** 10 bar

FUNCIONALIDADES

- **Sin mantenimiento**
- **Protección contra golpes de ariete**
- **Dimensiones compactas**
- **Sistema de protección integrado**
- **Evita sobredimensionado de la bomba**



IMPULSIÓN EN ÁNGULO 90°



ENCHUFE SCHUKO 1,5M

MODELO	I MÁX.	P MÁX.		FREC.	PESO	CONEXIONES		PRESIÓN	TEMP.	P.V.P.
		kW	Hp			ARRANQUE	MÁX			
CONTROLPUMP	10	1,5	2,0	50 / 60	1,2	Ø"	Ø"	bar	°C	72,00
	A	kW	Hp	Hz	Kg	1	1	1,5	50	

CONTROLADOR SERIE ECO

DESCRIPCIÓN

- Dispositivo compacto para el control automático y protección de electrobombas.
- Su funcionamiento adopta el control de la presión y caudal de la bomba, así como su **arranque y parada automáticos** en función de la demanda de agua.

CARACTERÍSTICAS

- **Cable a bomba:** 0,5 m
- **Cable a red:** 2 m con enchufe schuko
- **Potencia máx. bomba:** 1,1 kW
- **Protección:** IP64
- **Presión máxima:** 10 bar

FUNCIONALIDADES

- **Sin mantenimiento**
- **Protección contra golpes de ariete**
- **Dimensiones compactas**
- **Arranque forzado a los 10s**
- **Evita sobredimensionado de la bomba**
- **Botón de reseteo**



ENCHUFE SCHUKO 2M

MODELO	I MÁX.	P MÁX.		FREC.	PESO	CONEXIONES		PRESIÓN	TEMP.	P.V.P.
		kW	Hp			ARRANQUE	MÁX			
ECO	10	1,1	1,5	50 / 60	1,1	Ø"	Ø"	bar	°C	54,00
	A	kW	Hp	Hz	Kg	G1	G1	1,5	55	

CONTROLADOR SERIE PYD-5

DESCRIPCIÓN

- Dispositivo compacto para el control automático y protección de electrobombas.
- Su funcionamiento adopta el control de la presión y caudal de la bomba, así como su **arranque y parada automáticos** en función de la demanda de agua.

CARACTERÍSTICAS

- **Cable a bomba:** 0,5 m
- **Cable a red:** 2 m con enchufe schuko
- **Potencia máx. bomba:** 1,5 kW
- **Protección:** IP65
- **Terminales a bomba incluidos**
- **Presión máxima:** 10 bar



FUNCIONALIDADES

- **Presión de arranque ajustable**
- **Sin mantenimiento**
- **Protección contra golpes de ariete**
- **Dimensiones compactas**
- **Arranque forzado a los 10s**
- **Evita sobredimensionado de la bomba**
- **Botón de reseteo**



ENCHUFE SCHUKO 2M



TERMINALES INCLUIDOS

MODELO	I MÁX.	P MÁX.		FREC.	PESO	CONEXIONES		PRESIÓN	TEMP.	P.V.P.
		kW	Hp			ARRANQUE	MÁX			
PYD-5	10	1,1	1,5	50 / 60	1,4	Ø"	Ø"	bar	°C	58,00
						G1	G1	1,2 - 2,5	55	

CONTROLADOR SERIE PYD-5 ENCH

DESCRIPCIÓN

- Dispositivo compacto para el control automático y protección de electrobombas.
- Su funcionamiento adopta el control de la presión y caudal de la bomba, así como su **arranque y parada automáticos** en función de la demanda de agua.
- Mismas características que el modelo PYD-5 pero con **toma de enchufe en su frontal**.

CARACTERÍSTICAS

- **Cable a bomba:** 0,5m.
- **Cable a red:** 2 m con enchufe schuko
- **Potencia máx. bomba:** 1,5 kW
- **Protección:** IP44
- **Panel frontal:** Enchufe europeo
- **Presión máxima:** 10 bar



FUNCIONALIDADES

- **Presión de arranque ajustable**
- **Sin mantenimiento**
- **Protección contra golpes de ariete**
- **Dimensiones compactas**
- **Sistema de protección integrado**
- **Evita sobredimensionado de la bomba**
- **Botón de reseteo**



ENCHUFE SCHUKO 2M



ENCHUFE FRONTAL

MODELO	I MÁX.	P MÁX.		FREC.	PESO	CONEXIONES		PRESIÓN	TEMP.	P.V.P.
		kW	Hp			ARRANQUE	MÁX			
PYD-5 ENCH	10	1,5	2,0	50 / 60	1,4	Ø"	Ø"	bar	bar	°C
						G1	G1	1,2 - 2,5	10	55

CONTROLADOR SERIE PYD-15

DESCRIPCIÓN

- Dispositivo compacto para el control automático y protección de electrobombas.
- Su funcionamiento adopta el control de la presión y caudal de la bomba, así como su **arranque y parada automáticos** en función de la demanda de agua.
- Dispone de **3 modos de control** en función a las necesidades de la instalación.

CARACTERÍSTICAS

- **Cable a bomba:** 0,5m.
- **Cable a red:** 2 m con enchufe schuko
- **Potencia máx. bomba:** 1,5 kW
- **Protección:** IP65
- **Terminales a bomba incluidos**



FUNCIONALIDADES

- **Presión de arranque ajustable**
- **Sin mantenimiento**
- **Protección contra golpes de ariete**
- **Dimensiones compactas**
- **3 Modos de funcionamiento**
- **Evita sobredimensionado de la bomba**
- **Botón de reseteo**



ENCHUFE SCHUKO 1,5M



TERMINALES INCLUIDOS

MODELO	I MÁX.		P MÁX.		FREC.	CONEXIONES		PRESIÓN		TEMP.	P.V.P.
	A	kW	Hp	Hz	Kg	ENTRADA	SALIDA	ARRANQUE	MÁX	MÁX	
PYD-15	10	1,1	1,5	50 / 60	1,1	Ø"	Ø"	bar	bar	°C	65,00

3 MODOS DE CONTROL

1 MODO TIEMPO

Permite operar durante periodos específicos (0,5h, 6h o 24h) y apagándose después automáticamente. Ideal para llenado de depósitos y riego.

2 MODO CAUDAL

El sistema arranca cuando los sensores de caudal detectan una demanda de agua.

3 MODO PRESIÓN

El sistema arranca y para cuando la presión de la columna de agua baja según lo establecido.

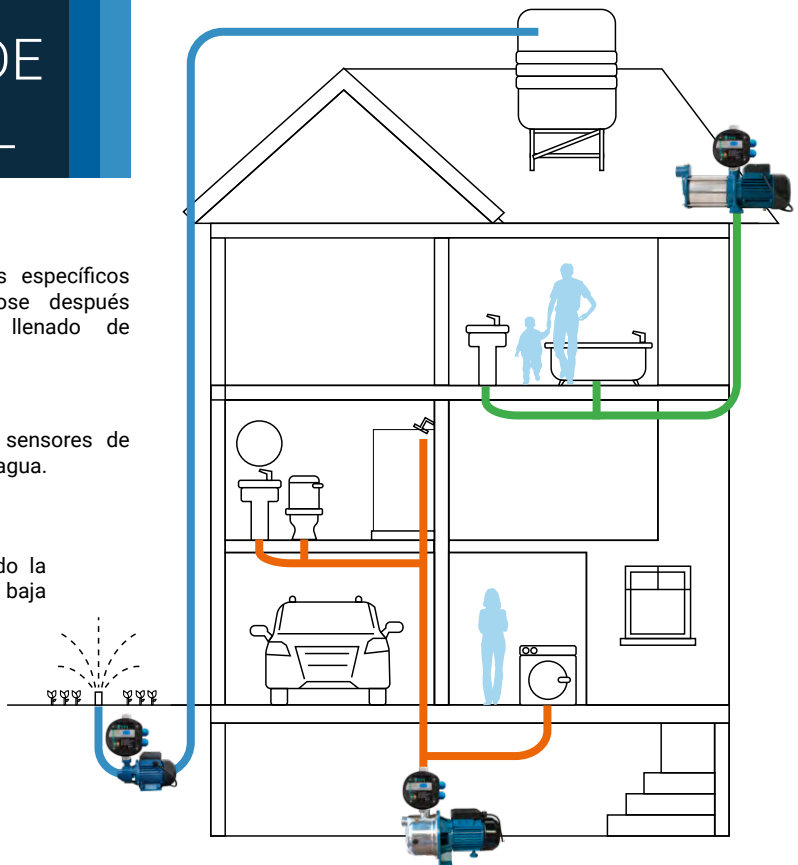

CONTROLADOR SERIE DIGI-PLUS

DESCRIPCIÓN

- Dispositivo para el control automático y protección de electrobombas.
- El Digi-Plus es un modelo multifunción que combina el **presostato electrónico y mecánico tradicional**.
- Incluye **2 modos de funcionamiento** en base a la presión de arranque.

CARACTERÍSTICAS

- **Cable a bomba:** 0,5m.
- **Cable a red:** 2 m con enchufe schuko
- **Potencia máx. bomba:** 2,2 kW
- **Protección:** IP65
- **Terminales a bomba incluidos**



FUNCIONALIDADES

- **Presiones ajustables**
- **Sin mantenimiento**
- **Protección contra golpes de ariete**
- **Dimensiones compactas**
- **Evita sobredimensionado de la bomba**
- **Botón de reseteo**
- **Pantalla digital integrada para visualizar la presión en tiempo real**



ENCHUFE SCHUKO 1,5M



TERMINALES INCLUIDOS

MODELO	I MÁX.	P MÁX.	FREC.	PESO	CONEXIONES		PRESIÓN		TEMP.	P.V.P.	
					ENTRADA	SALIDA	ARRANQUE	PARADA	MÁX		
DIGI-PLUS	30	2,2	3,0	50 / 60	1,3	Ø"	Ø"	bar	bar	°C	94,00
	A	kW	Hp	Hz	Kg	G1	G1	0,5 - 6,7	0,8 - 7,0	60	

CONTROLADORES DE PRESIÓN



HASTA 3HP

MODO 1 (AUTO)

El sistema se activa únicamente **cuando la presión cae por debajo del valor establecido**, encendiendo la bomba para mantener el suministro adecuado.

MODO 2 (MANUAL)

Este modo permite **configurar tanto la presión de arranque como la de parada** de la bomba, asegurando un control más preciso del rango de funcionamiento.

CONTROLADOR SERIE EURO-2

DESCRIPCIÓN

- Dispositivo compacto para el control automático y protección de electrobombas.
- Su funcionamiento adopta el control de la presión y caudal de la bomba, así como su **arranque y parada automáticos** en función de la demanda de agua.
- Conexión de tubería a 90°.

CARACTERÍSTICAS

- **Cable a bomba:** 0,5m.
- **Cable a red:** 2 m con enchufe schuko
- **Potencia máx. bomba:** 1,5 kW
- **Protección:** IP65
- **Terminales a bomba incluidos**



FUNCIONALIDADES

- **Presión de arranque ajustable**
- **Sin mantenimiento**
- **Protección contra golpes de ariete**
- **Dimensiones compactas**
- **Evita sobredimensionado de la bomba**
- **Botón de reseteo**



IMPULSIÓN EN ÁNGULO 90°



ENCHUFE SCHUKO 2 M



TERMINALES INCLUIDOS

MODELO	I MÁX.	P MÁX.		FREC.	PESO	CONEXIONES		PRESIÓN		TEMP.	P.V.P.
		kW	Hp			ENTRADA	SALIDA	ARRANQUE	MÁX	MÁX	
EURO-2	10	1,1	1,5	50 / 60	1,3	Ø"	Ø"	bar	bar	°C	56,00
						G1	G1	1,2 - 2,5	10	55	

SERIE OPTIPLUS

DESCRIPCIÓN

- Aparato compacto para el control automático y protección de electrobombas monofásicas.
- Dispone de un **Sistema de protección** contra el funcionamiento en seco de la bomba.
- **Función ART**, reinicio mediante puestas en marcha automáticas tras detectar un fallo.

CARACTERÍSTICAS

- **Sensores específicos de flujo y de presión** integrados en el circuito electrónico (permiten el correcto funcionamiento de la bomba manteniendo el suministro mientras haya demanda)
- **Manómetro incorporado**



MODELO	I MÁX.	P MÁX.		FREC.	PESO	CONEXIONES		PRESIÓN		TEMP.	P.V.P.
		kW	Hp			ENTRADA	SALIDA	ARRANQUE	MÁX	MÁX	
OPTIPLUS 22	16	2,2	3,0	50/60	1,3	Ø"	Ø"	bar	bar	°C	155,00
						1 1/4"	1 1/4"	1,5 - 2,5	10	60	

DESCRIPCIÓN

- SWITCHMATIC y SWITCHMATIC 2 son presostatos electrónicos con **manómetro digital integrado** que permiten gestionar la puesta en marcha y paro de una bomba monofásica de **hasta 3,0 HP**.
- Las presiones son fácilmente ajustables a través del panel de control de usuario.
- El cableado se realiza de una forma análoga al de un presostato electromecánico tradicional.
- Puede operar como un interruptor de presión diferencial, de presión inversada o simplemente con máxima y mínima presión.
- La unidad SWITCHMATIC 2 **incluye la lectura de corriente consumida instantánea**. Este sistema controla y gestiona la sobreintensidad, el funcionamiento en seco y los ciclos rápidos de funcionamiento.
- Funcionamiento con alternancia y arranque en cascada para grupos con doble bomba monofásica.
- **Necesita calderín.**



CARACTERÍSTICAS

- Grado de protección: **IP55**

ÁREA DE TRABAJO

- Temperatura máx. del agua: **40°C**
- Temperatura máx. ambiente: **50°C**

MODELO	BOMBAS CANT.	CONEX. Ø"	PESO Kg	PRESIÓN		DIFERENCIAL		TENSIÓN V	INT. MÁXIMA A	POTENCIA MÁXIMA HP	P.V.P. A
				MARCHA	PARO	MÍNIMO	MÁXIMO				
SWITCHMATIC	1	1/4	0,4	0,5 ÷ 11,5	1 ÷ 12	0,3	11,5	~1 x 110-230	16	3	60,00
SWITCHMATIC2	1	1/4	0,4	0,5 ÷ 11,5	1 ÷ 12	0,5	11,5	~1 x 110-230	16	3	85,00

PRESOSTATOS ELECTRÓNICOS SWITCHMATIC 2T

DESCRIPCIÓN

- La unidad Switchmatic 2T es un presostato electrónico trifásico con manómetro digital integrado.
- Permite gestionar la puesta en marcha y paro de una bomba trifásica **hasta 5,5 HP**.
- Las presiones son fácilmente ajustables a través del panel de control de usuario.
- El cableado se realiza de forma análoga al de un presostato electromecánico tradicional.
- El Switchmatic 2T **incluye la lectura de corriente consumida instantánea y voltaje**.
- Puede ser montado individualmente o en grupos de 2 bombas operando en cascada y con secuencia de puesta en marcha alternada. Este sistema patentado controla y gestiona la sobreintensidad, voltaje fuera de rango, el funcionamiento en seco y los ciclos rápidos de funcionamiento.



CARACTERÍSTICAS

- Grado de protección: **IP55**

ÁREA DE TRABAJO

- Temperatura máx. del agua: **40°C**
- Temperatura máx. ambiente: **50°C**

MODELO	BOMBAS CANT.	CONEX. Ø"	PESO Kg	PRESIÓN		DIFERENCIAL		TENSIÓN V	INT. MÁXIMA A	POTENCIA MÁXIMA HP	P.V.P. A
				MARCHA	PARO	MÍNIMO	MÁXIMO				
SWITCHMATIC 2T	1	1/4"	0,7	0,5 ÷ 11,5	1 ÷ 12	0,5	1,5	~3 x 230-400	12	5,5	190,00

DESCRIPCIÓN

- El SWITCHMATIC 3 es un presostato electrónico con **manómetro digital integrado**. Las presiones son fácilmente ajustables a través del panel de control de usuario. El cableado se realiza de forma análoga al de un presostato electromecánico tradicional.
- Su salida de libre potencial es ideal para transmitir una señal de abrir o cerrar el circuito hacia un panel de control.
- Puede ser alimentado (1~48Vac ÷ 230Vac) desde el panel de control o a través de la red eléctrica.



CARACTERÍSTICAS

- Grado de protección: **IP55**

ÁREA DE TRABAJO

- Temperatura máx. del agua: **55°C**
- Temperatura máx. ambiente: **60°C**



MODELO	CONEX. Ø"	PESO Kg	PRESIÓN		DIFERENCIAL		FRECUENCIA	TENSIÓN	INT. MÁXIMA	POTENCIA MÁXIMA	P.V.P.
			MARCHA	PARO	MÍNIMO	MÁXIMO					
SWITCHMATIC 3	1/4	0,4	bar		0,3	11,5	50/60	Vdc	A	HP	64,00
			0,5 ÷ 11,5	1 ÷ 12				~1 x 48-230	10	3	

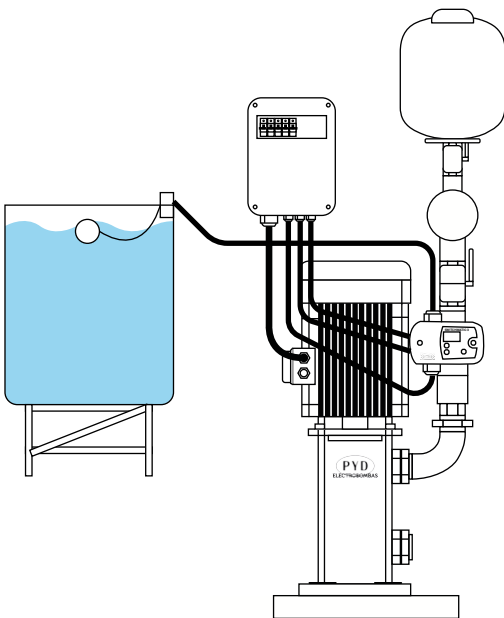

FUNCIONES

- ✓ **Transductor de presión interno** con indicador digital.
- ✓ **Manómetro interno** en bar y psi con lectura instantánea digital.
- ✓ **Panel de mandos y display** numérico de 3 cifras, indicadores led luminosos y pulsadores.
- ✓ **Protección contra funcionamiento en seco** por presión mínima.
- ✓ **Función ART** (Automatic Reset Test). Cuando el dispositivo se encuentra desconectado por la intervención del sistema de protección por falta de agua, el ART intenta, con una periodicidad programada, conectar el dispositivo hasta el restablecimiento de la alimentación de agua.
- ✓ **Alarma de ciclos rápidos marcha-paro**: Cuando el tanque hidropneumático ha perdido aire y se producen frecuentes paradas y arrancadas se activa una alarma.
- ✓ **Modo stand-by** con bajo consumo de potencia.
- ✓ **Pulsador** de puesta en marcha manual.
- ✓ **Modalidades de funcionamiento**: Diferencial e inversado.
- ✓ **Menú de configuración experto**: Diferenciales, tiempos de retardo y otros ajustes.

DESCRIPCIÓN

- El T-KIT Switchmatic es un **presostato electrónico integrado** en una **válvula de tres vías con manómetro digital integrado**. Puede controlar la presión de puesta en marcha y paro de una bomba monofásica hasta 3,0 HP.
- Las presiones son fácilmente ajustables a través del panel de control de usuario. El cableado se realiza de forma análoga al de un presostato electromecánico tradicional.
- Puede operar como un presostato de presión diferencial o de presión inversada. Alberga una válvula anti-retorno en su interior.
- T-KIT Switchmatic 2 **incluye la lectura de corriente consumida instantánea**. Este sistema patentado controla y gestiona la sobreintensidad, el funcionamiento en seco y los ciclos rápidos de funcionamiento.



CARACTERÍSTICAS

- Grado de protección: **IP55**

ÁREA DE TRABAJO

- Temperatura máx. del agua: **55°C**
- Temperatura máx. ambiente: **60°C**

MODELO	BOMBAS CANT.	CONEX. Ø"	PESO Kg	PRESIÓN		DIFERENCIAL		TENSIÓN	INT.	POTENCIA	P.V.P.
				MARCHA	PARO	MÍNIMO	MÁXIMO		MÁXIMA	MÁXIMA	
T-KIT SWITCHMATIC 1	1	1	0,6	bar		bar		Vac	A	HP	89,00
T-KIT SWITCHMATIC 2	1	1	0,6	0,5 ÷ 7	1 ÷ 8	0,5 ÷ 0,5	7,5	~1 x 110-230	16	3	99,00

CONTROLADORES DE PRESIÓN

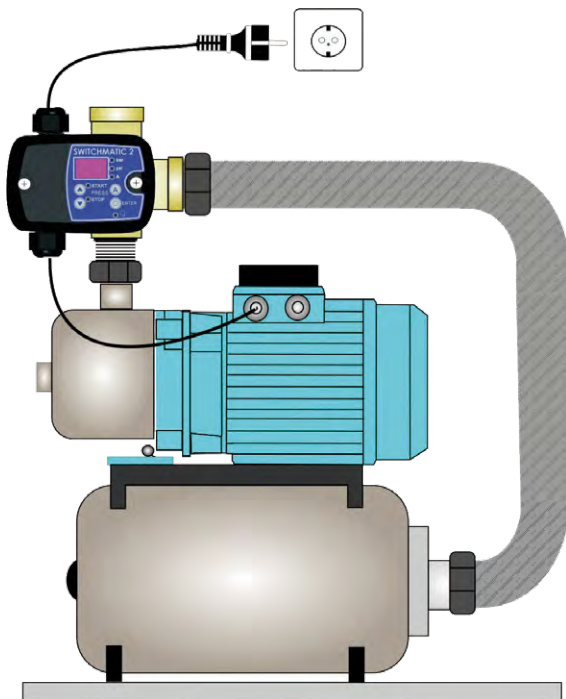

FUNCIONES

- ✔ **Válvula anti-retorno incorporada.**
- ✔ **Modo stand-by** con bajo consumo de potencia.
- ✔ **Transductor de presión interno** con indicador digital.
- ✔ **Manómetro interno** en BAR y PSI con lectura instantánea digital.
- ✔ **Panel de mandos y display numérico** de 3 cifras, indicadores led luminosos y pulsadores.
- ✔ **Protección contra funcionamiento en seco** por intensidad (T-KIT Switchmatic 2) y por presión mínima (T-KIT Switchmatic 1).
- ✔ **Función ART** (Automatic Reset Test). Si el sistema de protección desconecta el dispositivo por falta de agua, el ART intentará reconectarlo periódicamente hasta que se restablezca el suministro.
- ✔ **Protección contra sobreintensidad** (T-KIT Switchmatic 2).
- ✔ **Alarma de ciclo rápido:** Si el tanque hidropneumático pierde aire y causa paradas frecuentes, se activa una alarma.
- ✔ **Pulsador de puesta en marcha manual.**
- ✔ **Modalidades de funcionamiento:** Diferencial, inversado y sincronizado (T-KIT Switchmatic 2).
- ✔ **Menú de configuración experto:** Diferenciales, tiempos de retardo y otros ajustes.
- ✔ **Certificado EMC y certificado de seguridad eléctrica.**
- ✔ **Conforme a RoHS 2 y WEEE .**



VARIADORES ELECTRÓNICOS



BEDFORD SERIE W713B

DESCRIPCIÓN

- Variador de frecuencia avanzado, diseñado para cubrir las necesidades del usuario.
- Adecuado para todo tipo de bombas de superficie, horizontales o verticales, con un sistema único de fácil adaptación.
- **Mantiene una presión constante sin necesidad de manipulación** de acuerdo a la necesidad puntual de demanda de agua.
- **Parada automática y rearme al vuelo**, incluso tras pérdida de tensión en la alimentación del variador.
- **Protección contra el trabajo en seco** y control de nivel del depósito mediante sensor.
- **Control centralizado** opcional a través de conector RS485.
- **Grado de protección: IP54**
- **Nº máx. de bombas conectadas: Hasta 6**

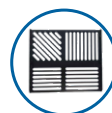

BASE DE MONTAJE UNIVERSAL

FUNCIONES



CONTROLADOR

Permite una temperatura y tensión constantes



MODO SLEEP

Activación automática del modo reposo



CONTROL REMOTO

Monitoriza el funcionamiento de tu equipo a través de la app



ANTIHIELO

Previene la congelación del agua dentro de las tuberías



ALTERNANCIA

Equilibra el uso de cada bomba aumentando su vida útil



REARME AUTOMÁTICO

Restablecimiento del suministro en caso de fallo eléctrico

MODELO	P ₂ MOTOR		FUNCIÓN ALTERNANCIA	TENSIÓN		INTENSIDAD (A)		P.V.P.
	kW	Hp		ENTRADA	SALIDA	ENTRADA	SALIDA	
W713B-4001	0,75	1,0	✓	3~380V	3~380V	3,4	2,1	616,00
W713B-4002	1,5	2,0	✓	3~380V	3~380V	5,0	3,8	625,00
W713B-4003	2,2	3,0	✓	3~380V	3~380V	5,8	5,1	634,00
W713B-4004	3,0	4,0	✓	3~380V	3~380V	9,0	6,8	638,00
W713B-4005	4,0	5,5	✓	3~380V	3~380V	13,5	9,5	788,00
W713B-4007	5,5	7,5	✓	3~380V	3~380V	19,5	14,0	792,00
W713B-4010	7,5	10,0	✓	3~380V	3~380V	25,0	18,5	814,00
W713B-4015	11,0	15,0	✓	3~380V	3~380V	32,0	25,0	1.092,00
W713B-4020	15,0	20,0	✓	3~380V	3~380V	40,0	32,0	1.255,00
W713B-4025	18,5	25,0	✓	3~380V	3~380V	47,0	38,0	1.272,00



ACCEDER A NUESTRA WEB Y DESCUBRE NUESTROS VIDEOTUTORIALES PARA LA CONFIGURACIÓN





PROTECCIÓN DEL MOTOR

- ✓ Sobrecarga eléctrica
- ✓ Cortocircuito
- ✓ Circuito abierto
- ✓ Sobre calentamiento
- ✓ Exceso de tensión / baja tensión



DISPLAY DIGITAL

Permite la **visualización y configuración de parámetros** operativos, así como la supervisión de códigos de error en tiempo real



FUNCIÓN ALTERNANCIA

Cambia automáticamente entre las distintas bombas del equipo hidráulico, garantizando un funcionamiento más equilibrado y prolongando su vida útil.



CONEXIONES

El variador cuenta con la **capacidad de integrar un sensor de flujo y un interruptor de nivel tipo boya**, permitiendo un control avanzado y adaptativo del sistema en función de las condiciones operativas del fluido y los niveles de llenado

BEDFORD SERIE WLD191



DESCRIPCIÓN

- El variador de frecuencia WLD191 **permite adecuar y mantener el caudal y la presión de la bomba** adaptándose a las necesidades de la instalación.
- Especialmente diseñado para bombas de agua ofrece una mejora en la eficiencia energética y una mayor vida útil.
- Ideal para sistemas de riego, distribución de agua potable, y aplicaciones industriales donde se requiere un control preciso del flujo de líquidos.



PROTECCIÓN

- ✓ **Baja tensión**
- ✓ **Sobretensión**
- ✓ **Sobrecorriente**
- ✓ **Sobrecalentamiento**
- ✓ **Pérdida de fase**
- ✓ **Alta presión del agua**
- ✓ **Baja presión del agua**
- ✓ **Circuito abierto el sensor**
- ✓ **Otras funciones de protección contra fallos**

FUNCIONES



Rearme automático en caso de fallo eléctrico.



Funciones de alarma de avería en el suministro.



Transductor de presión externo incluido.



Funcionamiento sencillo

MODELO	ENTRADA		SALIDA			P.V.P. ^B
	TENSIÓN	HZ	TENSIÓN	kW	Hp	
WLD191	1~220V	50 / 60	1~220V	1,1	1,5	308,00
			3~220V	2,2	3,0	

ESQUEMA DE CONEXIÓN

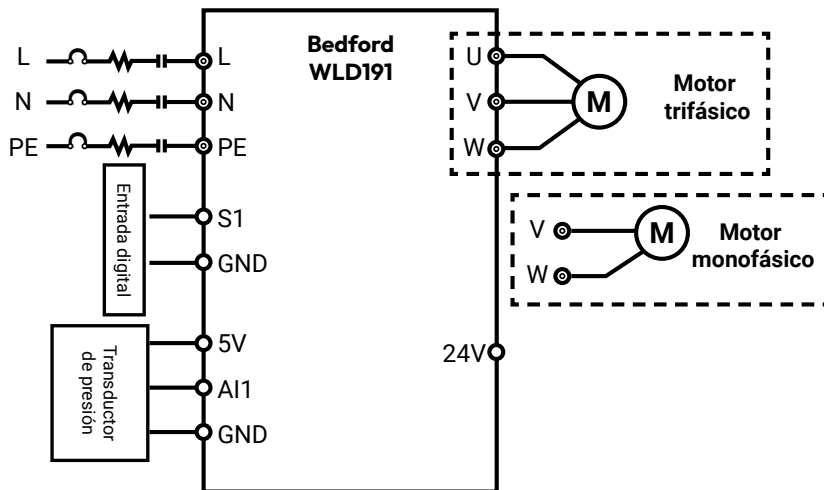

DESCRIPCIÓN

- Kit de presión diseñado para **optimizar el rendimiento** de una electrobomba doméstica horizontal, asegurando un **suministro de agua constante** y eficiente.
- Este sistema incluye el **variador de frecuencia Bedford WLD191**, que permite ajustar y regular la presión de manera automática, optimizando el consumo energético y prolongando la vida útil de la bomba.
- Ideal para aplicaciones residenciales, garantizando un **funcionamiento silencioso** y una presión estable en toda la red de suministro de agua.



ELECTROBOMBA

El modelo de bomba debe seleccionarse según los siguientes requisitos:

- Monofásica: 1~230V hasta 1,5hp
- Trifásica: 3~230V hasta 3,0hp
- Intensidad máxima: 10A.
- DN de impulsión: 1"

MODELO	POTENCIA		HIDROSFERA		MANÓMETRO GLIC.	RACORD 5 VÍAS	VARIADOR	+ BOMBA A ELEGIR*	P.V.P.
	1~230V	3~230V	VOL.	PRES.MÁX	PRES.MÁX.	CONEX.	Modelo		
KIT PRESIÓN + WLD191	≤ 1,5 Hp	≤ 3,0 Hp	L	bar	bar	"	WLD191		410,00

(*) Se debe sumar el PVP de la bomba seleccionada al Kit de Presión.

**CONTROL INTELIGENTE
EN CADA ARRANQUE**



VARIADORES DE FRECUENCIA SPEEDMATIC EASY

DESCRIPCIÓN

- Variadores de frecuencia in-line con alimentación monofásica y salida monofásica o trifásica a 230V.

PROTECCIÓN

- Sistema de control y protección de las electrobombas contra sobreintensidades.
- Sistema de protección contra el funcionamiento de las electrobombas en seco por falta de agua.
- Tensión de alimentación anómala.
- Cortocircuito entre fases de salida del sistema.
- Sumergible.



MODELO	BOMBAS CANT.	CONEX. Ø"	TENSIÓN		I MÁX.	POTENCIA MÁX.	PRESIÓN MÁX.	TEMP. MÁX.	CAUDAL MÁX.	PESO NETO	P.V.P.
			ENTRADA	SALIDA							
EASY 10	1	1 ¼"	1~230	3~230	10	3	8	40	10.000	2,5	576,00
EASY 12	1	1 ¼"	1~230	1~230	12	2	8	40	10.000	2,5	561,00

SPEEDBOX

DESCRIPCIÓN

- Variador de frecuencia de instalación sobre mural (SPEEDBOX) para bombas tanto monofásicas como trifásicas, que ajusta las revoluciones del motor en función de la demanda de caudal.
- Registro de controles operacionales (horas de funcionamiento, contador de arranque, contador de conexiones a red eléctrica) y de alarmas (tipo y número de alarmas generadas desde la puesta en marcha).

PROTECCIÓN

- Sistema de control y seguridad contra sobreintensidades.
- Control electrónico y sistema de seguridad contra funcionamiento en seco de las electrobombas (ART- Automatic Reset Test)
- Tensión de alimentación anómala.
- Sistema automático de rearme.
- Cortocircuito.



MODELO	POTENCIA MÁX.		I MÁX.	PESO	TENSIÓN		FRECUENCIA		P.V.P.
	kW	Hp			ENTRADA	SALIDA	ENTRADA	SALIDA	
SPEEDBOX 1112	2,2	3,0	12	3,5	1~230	1~230	50/60	0 - 55	826,00
SPEEDBOX 1010	2,2	3,0	10	4,5	1~230	3~230	50/60	0 - 55	885,00
SPEEDBOX 1305	2,2	3,0	5	5,1	3~380	3~380	50/60	0 - 55	959,00
SPEEDBOX 1309	4,0	5,5	9	5,1	3~380	3~380	50/60	0 - 55	1.049,00
SPEEDBOX 1314	5,5	7,4	14	4,5	3~380	3~380	50/60	0 - 55	1.157,00

SPEEDBOX DUO

DESCRIPCIÓN

- Variador de frecuencia de instalación sobre mural (SPEEDBOX). Bombas trifásicas o monofásicas controladas por dos INVERTERS.
- La alimentación eléctrica del dispositivo es monofásica a 230V.
- El aparato hace trabajar en cascada y en alternancia ambas bombas.
- Cada bomba está controlada por un **inverter**.

PROTECCIÓN

- Sistema de control y protección de las electrobombas contra sobreintensidades.
- Sistema de protección contra el funcionamiento de las electrobombas en seco por falta de agua.
- Tensión de alimentación anómala.
- Cortocircuito entre fases de salida del sistema.
- Detección fallo transductor.
- Entrada del transductor: IP55
- Sistema de enfriamiento: Convección forzada



MODELO	RANGO DE REGULACIÓN	FRECUENCIA	TEMPERATURA AMBIENTE MÁX.	TENSIÓN	INTENSIDAD MÁX. POR BOMBA	PESO		P.V.P.
						Kg	A	
SPEEDBOX DUO	0,5 ÷ 16 bar	50/60 Hz	50 °C	~1 x 230 Vac	10A (~3 x 230 Vac) o 12A (~1 x 230 Vac) 10A (~3 x 230 Vac) o 12A (~1 x 230 Vac)	4,8		1.328,00

SPEEDBOX DUO SET

DESCRIPCIÓN

- Variador de frecuencia de instalación sobre mural (SPEEDBOX). El SPEEDBOX DUO SET es un aparato compacto para el control de grupos de presión de 2 bombas con **sistema electrónico gestionado por un software** que responde a las rigurosas exigencias de eficacia y seguridad de los más importantes constructores de bombas.
- Incluye un **INVERTER** (variador de frecuencia) para el control de la bomba principal regulando su velocidad para mantener constante y fija la presión óptima en la instalación, independientemente del caudal que el grupo está suministrando. La bomba auxiliar está gestionada mediante un relé de potencia.
- La secuencia de funcionamiento de las bombas es alternada, en cada ciclo de funcionamiento cambia la primera bomba en ponerse en marcha y siempre se pone en marcha a través del variador.



PROTECCIÓN

- Sistema de control y protección de las electrobombas contra sobreintensidades.
- Sistema de protección contra el funcionamiento de las electrobombas en seco por falta de agua.
- Tensión de alimentación anómala.
- Cortocircuito entre fases de salida del sistema.
- Detección fallo transductor.
- Entrada del transductor: IP55
- Sistema de enfriamiento: Convección forzada

MODELO	RANGO DE REGULACIÓN	FRECUENCIA	TEMPERATURA AMBIENTE MÁX.	TENSIÓN	INTENSIDAD MÁX. POR BOMBA	PESO		P.V.P.
						Kg	A	
SPEEDBOX DUO SET	0,5 ÷ 16 bar	50/60 Hz	50 °C	~3 x 400 Vac	9 A (~3 x 400 Vac)	4,8		NO DISPONIBLE

CUADRO PROTECCIÓN PARA VARIADORES SERIE VSC

DESCRIPCIÓN

- Sistema diseñado para la **protección por cortocircuito y gestión eficiente de variadores de frecuencia** en instalaciones de bombeo.
- Permite la conexión y desconexión manual del suministro eléctrico de la instalación para una mayor comodidad.
- Diseño **compacto y robusto** ideal para sistemas de bombeo industriales, agrícolas y de abastecimiento de agua.



1 BOMBA				2 BOMBAS				3 BOMBAS			
MODELO	POTENCIA		P.V.P.	MODELO	POTENCIA		P.V.P.	MODELO	POTENCIA		P.V.P.
	MONOF.	TRIF.			MONOF.	TRIF.			MONOF.	TRIF.	
VSC-1B10	≤ 3 Hp	≤ 10 Hp	123,90	VSC-2B10	≤ 3 Hp	≤ 10 Hp	189,30	VSC-3B10	≤ 3 Hp	≤ 10 Hp	258,20
VSC-1B15	-	≤ 15 Hp	130,80	VSC-2B15	-	≤ 15 Hp	203,10	VSC-3B15	-	≤ 15 Hp	275,40
VSC-1B20	-	≤ 20 Hp	137,70	VSC-2B20	-	≤ 20 Hp	254,70	VSC-3B20	-	≤ 20 Hp	337,30
VSC-1B25	-	≤ 25 Hp	144,60	VSC-2B25	-	≤ 25 Hp	275,40	VSC-3B25	-	≤ 25 Hp	378,60



CARACTERÍSTICAS

- ✓ Disponibles para 1, 2, 3 o más bombas (consulte a nuestro dpto comercial).
- ✓ Conexión mediante bornes de entrada y salida directa desde magnetotérmico (ajustado según la potencia de las bombas).
- ✓ Cajas de mecanismos IP40 de 6, 8, 12 o 24 módulos, según los elementos incorporados.
- ✓ Prensaestopas preparados para la salida de bombas y compatibilidad con mangueras.
- ✓ Opcional: Diferenciales, magnetotérmicos generales, relojes programadores y otros elementos según necesidades.



CUADROS DE PROTECCIÓN Y ALTERNANCIA



CUADROS MULTIFUNCIÓN SERIE ALLINONE

DESCRIPCIÓN

- Cuadros eléctricos de control multifunción diseñados para gestionar el funcionamiento de una o dos bombas en aplicaciones como grupos de presión, estaciones de aguas residuales y control de pozos o depósitos.
- Permite comandar **bombas hasta 13 A.**
- Grado de protección: **IP54**
- Un único cuadro hace las funciones de **cuadro de protección y alternancia, cuadro de pozo con sondas y cuadro de aguas residuales o pluviales.**



El mismo cuadro permite operar con tensión monofásica o trifásica según las siguientes configuraciones:

- ✓ **Config. monofásica:** Admite una tensión de entrada monofásica (1~220) y está diseñado para la operación de electrobombas monofásicas con una potencia máxima de 2,0 Hp
- ✓ **Config. trifásica:** Admite una tensión de entrada trifásica (3~380) y está diseñado para la operación de electrobombas trifásicas con una potencia máxima de 5,5 Hp.

MODELO	Nº BOMBAS	CONFIG. MONOFÁSICA				CONFIG. TRIFÁSICA				P.V.P.
		I MÁX. A	T. ENTRADA V	T. BOMBA V	P. MÁX. Hp	T. ENTRADA V	T. BOMBA V	P. MÁX. Hp		
ALLINONE-1B	1	13	220/230	220/230	2,0	380/400	380/400	5,5	275,00	
ALLINONE-2B	2	13	220/230	220/230	2,0	380/400	380/400	5,5	407,00	

ESQUEMAS DE INSTALACIÓN

GRUPO DE PRESIÓN CON INTERRUPTOR DE NIVEL

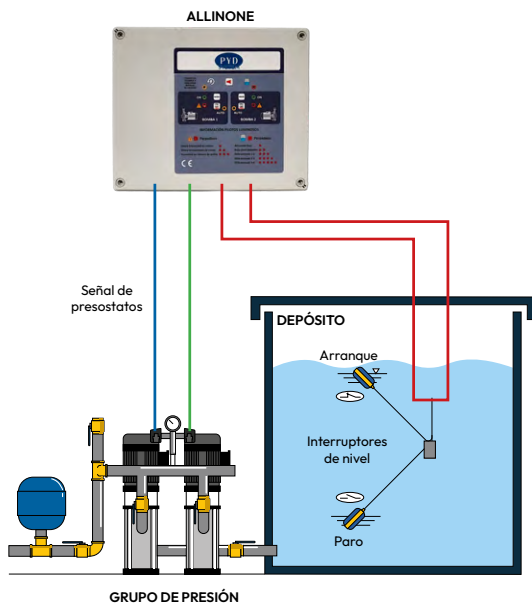

ELECTROBOMBAS DE AGUAS RESIDUALES CON BOYAS

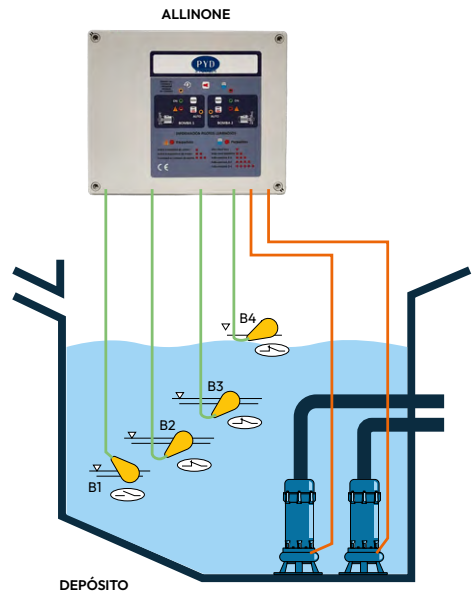

- B1: Boya de desconexión
- B2: Boya de arranque primer nivel
- B3: Boya de arranque segundo nivel
- B4: Boya de alarma arranque de emergencia



CONEXIÓN ELÉCTRICA

Compatible con sistemas monofásicos y trifásicos (230-400V) con bornes de maniobra y conexiones a tierra.



FÁCIL CONFIGURACIÓN

Selector de aplicaciones y número de sonda o boyas, además de temporización ajustable para rearme.



MATERIALES DE CALIDAD

Armario de ABS con protección IP65 y componentes de alta calidad para mayor durabilidad y seguridad.



AVISOS Y ALARMAS

Indicadores LED, zumbador acústico y pilotos para señalizar los fallos y errores.



SENSORES

Admite sondas de nivel, presostato y boyas para el control de arranque y paro



FUNCIONES AVANZADAS

Alternancia, funcionamiento en cascada y protección contra arranques súbitos.



UN SÓLO CUADRO

CONTROL TOTAL

CUADROS PROTECCIÓN Y ALTERNANCIA

PYD SYSTEM

CÓDIGO QR: ESCANEA Y DESCARGA MANUAL DE USUARIO

BOMBA 1 | **BOMBA 2**

ON | MAN | ON/OFF | AUTO

INFORMACIÓN PILOTOS LUMINOSOS

Parpadeos

- Sobre intensidad de motor
- Sobre temperatura de motor
- Humedad en cámara de aceite
- Alto nivel fosa
- Bajo nivel depósito
- Fallo entrada 1-2
- Fallo entrada 2-3
- Fallo entrada 3-4

CE



CUADROS DE PROTECCIÓN

DESCRIPCIÓN

- Cuadros eléctricos **contra sobrecarga, sobreintensidad y temperatura.**
- Provistos de un contacto libre para interruptor de nivel, alarma acústica, etc.
- Los cuadros dobles incorporan relé de alternancia, repartiendo los arranques y horas de trabajo entre los dos motores, alargando su vida útil.



MODELO (*)	TENSIÓN		P (Hp)		I (A)		P.V.P.
	V	MÍN	MÁX	MÍN	MÁX	PROTECCIÓN	
CUADRO 005 M	1~230		0,5		2,8	4,0	146,00
CUADRO 010 M	1~230	0,75	1,0	4,0	6,3		146,00
CUADRO 020 M	1~230	1,5	2,0	8,0	12,5		156,00
CUADRO 030 M	1~230		3,0	11,0	17,0		180,00

MODELO (*)	TENSIÓN		P (Hp)		I (A)		P.V.P.
	V	MÍN	MÁX	MÍN	MÁX	PROTECCIÓN	
CUADRO 005 T	3~400		0,5	1,2	1,8		160,00
CUADRO 008 T	3~400		0,75		1,8	2,0	153,00
CUADRO 010 T	3~400		1,0		1,8	2,8	153,00
CUADRO 015 T	3~400		1,5		2,8	4,0	153,00
CUADRO 030 T	3~400	2,0	3,0	4,0	6,3		153,00
CUADRO 040 T	3~400		4,0		7,0	10,0	153,00
CUADRO 055 T	3~400		5,5		8,0	12,5	163,00
CUADRO 075 T	3~400		7,5	11,0	17,0		187,00
CUADRO 125 T	3~400	10,0	12,5	15,0	23,0		222,00

CUADROS DE ALTERNANCIA

DESCRIPCIÓN

- Cuadro para maniobra y protección de 2 electrobombas en alternancia monofásico a 230V.
- Cuenta con **alarma acústica** por nivel máximo y salida a 230V para conexión de cualquier otro sistema.
- Los distintos niveles se pueden activar mediante boyas o sondas.
- Protección y maniobra mediante contactores y relés térmicos.



CUADROS DE PROTECCIÓN DOBLES CON ALTERNANCIA

MODELO	BOMBAS CANTIDAD	POTENCIA MÁXIMA		REGULACIÓN		P.V.P.	
		MONOFÁSICA	TRIFÁSICA	ARRANQUE	PARO	MONOF.	TRIF.
		Hp	Hp	A	A		
CUADRO D01	2	-	0,50	0,85	1,30	-	319,00
CUADRO D02	2	-	0,75	1,20	1,80	-	319,00
CUADRO D03	2	-	1,00	1,80	2,80	-	350,00
CUADRO D04	2	-	1,50	2,80	4,00	-	350,00
CUADRO D06	2	0,50	3,00	4,00	6,30	350,00	350,00
CUADRO D10	2	0,75 - 1,00	4,00	7,00	10,00	350,00	350,00
CUADRO D12	2	1,50 - 2,00	5,50	8,00	12,50	371,00	371,00
CUADRO D17	2	3,00	7,50	11,00	17,00	420,00	420,00

DESCRIPCIÓN

- Este dispositivo detiene la bomba cuando es detectado un funcionamiento en seco o una sobreintensidad de corriente.
- Integra un zócalo tipo Schuko para la conexión de la bomba.



CARACTERÍSTICAS

- **Auto-configurable.**
- Protección contra sobre-intensidad
- Grado de protección: **IP44**
- Temperatura máxima: **50 °C**



IDEAL PARA
BOMBAS DE ACHIQUE

MODELO	P		I MÁX.	PESO	TENSIÓN	FRECUENCIA	P.V.P. ^A
	kW	Hp	A	Kg	V	Hz	
SAFEMATIC	0,37- 2,2	0,50-3,0	16	0,4	~1 x 110-230	50/60 Hz	68,00

PRESOSTATOS DE ARRANQUE

DESCRIPCIÓN

- Dispositivo electromecánico que permite abrir o cerrar el circuito eléctrico en función de la presión.

CARACTERÍSTICAS

- Disponibles para 220V y 380V de tensión.
- Hasta 5 bar de presión máxima.
- **Modelo PX7** con manómetro y racor incluido.



PM - PT



PX3



PX7

MODELO	TENSIÓN	TOMA	PRES. MÍN	PRES. MÁX	P.V.P. ^B
	V	Ø"	bar	bar	
PX 3	220	1/4	1	5	9,00
PM 5	220	1/4	1	5	14,00
PT5	380	1/4	1	5	16,00
PX 7	220	1	1	5	15,00
PM 12	220	1/4	3	12	15,00
PT 12	380	1/4	3	12	17,00

MANÓMETROS

DESCRIPCIÓN

- Medidor de presión de diafragma fabricado totalmente en acero inoxidable.
- Es aplicable en la industria química, alimentaria y otros sectores.

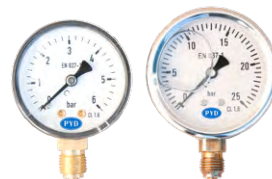

MODELO	TOMA	CAJA		PRES. MÁX	P.V.P. ^A
	Ø"	BAÑO	DN (mm)	bar	
M 6	1/4	Seco	50	6	4,95
M 10	1/4	Glicerina	63	10	11,55

RACCORD 5 VÍAS

MODELO	LONG.		CONEXIONES			P.V.P. ^C
	mm	Ø"	Ø"	Ø"	Ø"	
CORTO	80	1	1	1	1	7,75
LARGO	100	1	1	1	1	10,35



**RACCORD CURVO PORTAMANGUERAS - 3 PIEZAS
ROSCA GAS EN POLIAMIDA**

MODELO											P.V.P. ^A
	G1	DN	D	H	H1	L(a)	E	L	K		
200046.0732	1"	32	24,5	103	97	31	55	12	32	7,00	
200046.0940	1 1/4"	40	33	126	108	36	64	15	45	9,00	
200046.1150	1 1/2"	50	42	139	128	35	83	15,5	45	13,00	
200046.1550	2"	50	42	147	128	35	83	16,5	56	13,00	



**RACCORD RECTO PORTAMANGUERAS - 3 PIEZAS
ROSCA GAS EN POLIAMIDA**

MODELO											P.V.P. ^A
	G1	DN	D	H	L(a)	E	L	K			
200044.0732	1"	32	24	95	28	55	12	32	5,00		
200044.0940	1 1/4"	40	33	115	35	64	15	45	7,00		
200044.1150	1 1/2"	50	42,5	125	42	83	15,5	45	10,00		
200044.1550	2"	50	42,5	133	42,5	83	15,5	56	10,00		



TUBERÍA FLEXIBLE



ELECTRO-VÁLVULAS



MODELO	CONEXIONES		PRES MÁX. bar	P.V.P. ^C		
	M	H		300 mm	500 mm	800 mm
MALLA 20R	3/4"	3/4"	20	8,10	9,60	12,00
MALLA 25R	1"	1"	20	13,00	15,60	19,30
MALLA 30R	1 1/4"	1 1/4"	20	27,90	31,90	37,00
MALLA 40R	1 1/2"	1 1/2"	20	41,70	46,10	52,70
MALLA 50R	2"	2"	20	69,10	75,80	85,90
MALLA 25C	1"	1"	20	-	-	20,50

MODELO	DN Ø"	P.V.P. ^C	
		N. ABIERTA	N. CERRADA
EV1	3/8	126,00	102,00
EV2	1/2	127,00	103,00
EV3	3/4	178,00	153,00
EV4	1	204,00	168,00
EV5	1 1/4	408,00	331,00
EV6	1 1/2	430,00	351,00
EV7	2	504,00	479,00

* R=Recta ; C=Curva

INTERRUPTORES DE NIVEL PARA AGUAS LIMPIAS

DESCRIPCIÓN

Boyas para aguas limpias de ajuste automático, fácil de operar, seguro y fiable, respetuoso con el medio ambiente y no tóxico.



MODELO	TENSIÓN	CABLE	CONTRA	I MÁX	P.V.P.
	V	mts.	PESO	A	
BOYA-3	220-230	3	SÍ	10	14,00
BOYA-5	220-230	5	SÍ	10	19,00
BOYA-10	220-230	10	SÍ	10	30,00

INTERRUPTORES DE NIVEL PARA AGUAS RESIDUALES

DESCRIPCIÓN

Interruptores de nivel para condiciones extremas que permiten el comando de la bomba a través del cuadro eléctrico. Cada modelo puede configurarse para trabajar tanto en modo depósito (llenado) como en modo pozo (vaciado) a elección del instalador.

Todas fabricadas en PP y EPDM.

TAURUS



TAURUS-EX



FLOTEC



MODELO	TEMPERATURA	ÁNGULO	TENSIÓN	PROFUNDIDAD MÁX.	CONTRA PESO	LONG. CABLE	I MÁX	P.V.P.
	°C	ACTIVACIÓN	V	mts.	Externo	mts.	A	
Taurus *	50	20°	250	20	NO	6	10	74,00
Flotec **	50	45°	250	20	SI	6	10	71,00
Taurus-ex *	80	20°	4-40 (Vac)	20	NO	10	0,1	130,00

* Taurus = boya + fixing kit (Kit de fijación) ** Flotec = boya + contrapeso

ACCEDE A NUESTRA WEB Y DESCUBRE
EL SUMINISTRO DE BOMBEO MÁS COMPLETO



www.proindecsa.com





GRUPOS DE PRESIÓN





GRUPOS DE PRESIÓN

En **PYD**, nos especializamos en la **fabricación de grupos de presión** diseñados para garantizar el suministro automático de agua a presión en instalaciones que requieren un caudal variable. Nuestras soluciones son ideales para bloques de apartamentos, urbanizaciones, hoteles, residencias, campings, colegios y aplicaciones en procesos industriales, asegurando un suministro eficiente y fiable.

Ofrecemos grupos de presión en configuración **simple, doble, triple o con múltiples bombas**, disponibles con sistemas de alternancia o mediante variadores de frecuencia, optimizando el rendimiento energético y la estabilidad del sistema.



TABLAS DE SELECCIÓN DE CAUDAL Y ALTURA

Selección de un grupo de presión conociendo el número de plantas del edificio y el número de viviendas:

1. Obtenga de la tabla la presión del equipo, a partir del número de plantas del edificio, incluyendo el sótano si el grupo va a ir instalado en el mismo.
2. Seleccione el tipo de viviendas a las que el grupo va a dar servicio, de acuerdo con el siguiente cuadro.



1º ALTURA MANOMÉTRICA

A continuación, se presenta una tabla que muestra la altura manométrica del equipo en función del número de plantas o la altura total del edificio, incluyendo el sótano, en caso de que el grupo se instale en dicho nivel.

Número de plantas	1	2	3	4	5	6	7	8	9	10	11	12	13	14	15
Altura del edificio en metros	6	9	12	15	18	21	24	27	30	33	36	39	42	45	48
Presión del equipo en m.c.a.	18	22	26	30	33	37	41	45	49	53	57	61	66	69	72
Presión de arranque en Kg/cm ²	1,8	2,2	2,6	3,0	3,3	3,7	4,1	4,5	4,9	5,3	5,7	6,1	6,6	6,9	7,2

2º TIPO DE VIVIENDAS

A, B, C, D ó E, según la siguiente tabla:

Tipo de viviendas	TIPO A	TIPO B	TIPO C	TIPO D	TIPO E
Dependencias	1 cocina 1 baño	1 cocina 1 baño 1 aseo	1 cocina 2 baños	1 cocina 2 baños 2 aseos	1 cocina 3 baños

3º CAUDAL

Seleccione el caudal necesario en m³/h según el tipo y número de viviendas, de acuerdo con los siguientes cuadros:

Nº de viviendas	A	B	C	D	E	Nº de viviendas	A	B	C	D	E	Nº de viviendas	A	B	C	D	E
10	4,6	5,3	5,8	6,3	6,7	45	9,9	11,3	12,2	13,4	14,2	80	13,1	15,0	16,3	17,9	18,9
15	5,7	6,5	7,1	7,7	8,2	50	10,4	11,9	12,9	14,1	15,0	85	13,5	15,5	16,8	18,4	19,5
20	6,6	7,5	8,1	8,9	9,5	55	10,9	12,5	13,5	14,8	15,7	90	13,9	15,9	17,3	18,9	20,1
25	7,3	8,4	9,1	10,0	10,6	60	11,4	13,0	14,1	15,5	16,4	95	14,3	16,4	17,8	19,5	20,6
30	8,0	9,2	10,0	10,9	11,6	65	11,8	13,5	14,7	16,1	17,1	100	14,7	16,8	18,2	20,0	21,2
35	8,7	9,9	10,8	11,8	12,5	70	12,3	14,1	15,2	16,7	17,7	125	16,4	18,8	20,4	22,3	23,7
40	9,3	10,6	11,5	12,6	13,4	75	12,7	14,5	15,8	17,3	18,3	150	18,0	20,6	22,3	24,5	25,9

Conociendo ya la presión del equipo en m.c.a. (presión de arranque del equipo en Kg/cm²) y el caudal en m³/h, seleccione usted mismo en las siguientes páginas la bomba o bombas que proporcione/n, por exceso, dichos valores.

GP CON CUADRO DE PROTECCIÓN Y ALTERNANCIA

DESCRIPCIÓN

- Conjuntos hidroneumáticos de presión para el suministro automático de agua a bloques de apartamentos, urbanizaciones, hoteles e instalaciones que precisen gran caudal y presión.
- Es necesaria la instalación de un acumulador presurizado (no incluido) en la impulsión del grupo, haciendo función antiarriete, acumulación de agua presurizada y minimizando el número de arranques debido a la falta de presión en los puntos de suministro.
- Con cuadro electromecánico sobre soporte en bancada. Para otras ejecuciones o requerimientos de caudal y presión consulte con nuestro departamento técnico. Fabricamos grupos a medida.



MODELO	P ₂		CUADRO		CONEXIONES	
	kW	Hp	AUTOMATISMO	ASPIRACIÓN	COLECTOR	
GP VERTI 304TP	1,0	1,35	ALT-AD	1"	2"	
GP VERTI 306TP	1,5	2	ALT-AD	1"	2"	
GP VERTI 308TP	2,2	3	ALT-AD	1"	2"	
GP VERTI 354TP-A	1,5	2	ALT-AD	1 ½"	2"	
GP VERTI 355TP-A	1,9	2,5	ALT-AD	1 ½"	2"	
GP VERTI 356TP-A	2,2	3	ALT-AD	1 ½"	2"	
GP VERTI 358TP-A	3	4	ALT-AD	1 ½"	2"	
GP VERTI 554TP	2,2	3	ALT-AD	1 ½"	2"	
GP VERTI 556TP	3	4	ALT-AD	1 ½"	2"	
GP VERTI 557TP	4	5,5	ALT-AD	1 ½"	2"	
GP VERTI 356TI	2,2	3	ALT-AD	1 ½"	2"	
GP VERTI 358TI	3	4	ALT-AD	1 ½"	2"	
GP VERTI 3510TI	4	5,5	ALT-AD	1 ½"	2"	
GP VERTI 554TI	2,2	3	ALT-AD	1 ½"	2"	
GP VERTI 556TI	3	4	ALT-AD	1 ½"	2"	
GP VERTI 557TI	4	5,5	ALT-AD	1 ½"	2"	
GP U7V-300/6	2,2	3	ALT-AD	1 ¼"	2"	
GP U7V-400/8	3	4	ALT-AD	1 ¼"	2"	
GP U9V-400/7	3	4	ALT-AD	1 ½"	2"	
GP U9V-550/10	4	5,5	ALT-AD	1 ½"	2"	
GP U18V-550/6	4	5,5	ALT-AD	2"	2"	
GP U18V-750/8	5,5	7,5	ALT-AD	2"	2"	

GRUPOS PERSONALIZADOS

Consulte al comercial de su zona o póngase en contacto con nuestro dpto. técnico y pida presupuesto sin compromiso.



Disponible con electrobombas series Verti-P, Verti-I, Vertinox, CTV y Ultras V.

GP CON VARIADOR SPEEDBOARD

DESCRIPCIÓN

- Los equipos de presión **SPEEDBOARD** con variación de frecuencia para viviendas individuales o colectivas mantienen la presión constante en el suministro de agua, ajustándola a la demanda en tiempo real, gracias a un variador de velocidad de instalación on-board (directa sobre caja de bornas del motor), de muy fácil programación.
- Estos grupos incluyen **acumulador de 25l**.



MODELO	P ₂		CUADRO		CONEXIONES	
	kW	Hp	AUTOMATISMO	ASPIRACIÓN	COLECTOR	
SB VERTI 304TP	1,0	1,35	1305 TT	1"	2"	
SB VERTI 306TP	1,5	2	1305 TT	1"	2"	
SB VERTI 308TP	2,2	3	1309 TT	1"	2"	
SB VERTI 354TP-A	1,5	2	1305 TT	1 ½"	2"	
SB VERTI 355TP-A	1,9	2,5	1309 TT	1 ½"	2"	
SB VERTI 356TP-A	2,2	3	1309 TT	1 ½"	2"	
SB VERTI 358TP-A	3	4	1309 TT	1 ½"	2"	
SB VERTI 554TP	2,2	3	1309 TT	1 ½"	2"	
SB VERTI 556TP	3	4	1309 TT	1 ½"	2"	
SB VERTI 557TP	4	5,5	1309 TT	1 ½"	2"	
SB VERTI 356TI	2,2	3	1309 TT	1 ½"	2"	
SB VERTI 358TI	3	4	1309 TT	1 ½"	2"	
SB VERTI 3510TI	4	5,5	1309 TT	1 ½"	2"	
SB VERTI 554TI	2,2	3	1309 TT	1 ½"	2"	
SB VERTI 556TI	3	4	1309 TT	1 ½"	2"	
SB VERTI 557TI	4	5,5	1309 TT	1 ½"	2"	
SB U7V-300/6	2,2	3	1309 TT	1 ¼"	2"	
SB U7V-400/8	3	4	1309 TT	1 ¼"	2"	
SB U9V-400/7	3	4	1309 TT	1 ½"	2"	
SB U9V-550/10	4	5,5	1309 TT	1 ½"	2"	
SB U18V-550/6	4	5,5	1309 TT	2"	2"	
SB U18V-750/8	5,5	7,5	1309 TT	2"	2"	

GRUPOS PERSONALIZADOS

Consulte al comercial de su zona o póngase en contacto con nuestro dpto. técnico y pida presupuesto sin compromiso.



Disponible con electrobombas series Verti-P, Verti-I, Vertinox, CTV y Ultras V.

GP CON VARIADOR BEDFORD

DESCRIPCIÓN

- Los equipos de presión **BEDFORD** con variación de frecuencia para viviendas individuales o colectivas mantienen una presión constante en el suministro de agua, ajustándola a la demanda en tiempo real, gracias a un variador de velocidad de instalación on-board, de muy fácil programación.
- Estos grupos **incluyen el acumulador**.



MODELO	P ₂		CUADRO		CONEXIONES	
	kW	Hp	AUTOMATISMO	ASPIRACIÓN	COLECTOR	
GB VERTI 304TP	1,0	1,35	B603-4002	1"	2"	
GB VERTI 306TP	1,5	2	B603-4002	1"	2"	
GB VERTI 308TP	2,2	3	B603-4003	1"	2"	
GB VERTI 354TP-A	1,5	2	B603B-4002	1 ½"	2"	
GB VERTI 355TP-A	1,9	2,5	B603B-4003	1 ½"	2"	
GB VERTI 356TP-A	2,2	3	B603B-4003	1 ½"	2"	
GB VERTI 358TP-A	3	4	B603-4005	1 ½"	2"	
GB VERTI 554TP	2,2	3	B603-4003	1 ½"	2"	
GB VERTI 556TP	3	4	B603-4005	1 ½"	2"	
GB VERTI 557TP	4	5,5	B603-4005	1 ½"	2"	
GB VERTI 356TI	2,2	3	B603-4003	1 ½"	2"	
GB VERTI 358TI	3	4	B603-4005	1 ½"	2"	
GB VERTI 3510TI	4	5,5	B603-4005	1 ½"	2"	
GB VERTI 554TI	2,2	3	B603-4003	1 ½"	2"	
GB VERTI 556TI	3	4	B603-4005	1 ½"	2"	
GB VERTI 557TI	4	5,5	B603-4005	1 ½"	2"	
GB U7V-300/6	2,2	3	B603-4003	1 ¼"	2"	
GB U7V-400/8	3	4	B603-4005	1 ¼"	2"	
GB U9V-400/7	3	4	B603-4005	1 ½"	2"	
GB U9V-550/10	4	5,5	B603-4005	1 ½"	2"	
GB U18V-550/6	4	5,5	B603-4005	2"	2"	
GB U18V-750/8	5,5	7,5	B603-4005	2"	2"	

GRUPOS PERSONALIZADOS

Consulte al comercial de su zona o póngase en contacto con nuestro dpto. técnico y pida presupuesto sin compromiso.



Disponible con electrobombas series Verti-P, Verti-I, Vertinox, CTV y Ultras V.

CON PRESOSTATO ELECTRÓNICO SWITCHMATIC 2

DESCRIPCIÓN

- Equipos de presión **SWITCHMATIC 2** con protección y alternancia para bombas monofásicas hasta 3 Hp, trabajo en modo presostático con valores de marcha y paro establecidos.
- Montaje sencillo sobre colector de impulsión, sin necesidad de presostatos, cuadro de protección ni soporte.



MODELO	TENSIÓN		P ₂		CUADRO	CONEXIONES		A
	V	kW	Hp	AUTOMATISMO	ASPIRACIÓN	COLECTOR		
SW VERTI 254MP	1~230	0,75	1	SWITCHMATIC2	1"	2"		
SW VERTI 255MP	1~230	1	1,35	SWITCHMATIC2	1"	2"		
SW VERTI 257MP	1~230	1	1,35	SWITCHMATIC2	1"	2"		
SW VERTI 304MP	1~230	1	1,35	SWITCHMATIC2	1"	2"		
SW VERTI 306MP	1~230	1,5	2	SWITCHMATIC2	1"	2"		
SW VERTI 354MP-A	1~230	1,5	2	SWITCHMATIC2	1 ½"	2"		
SW VERTI 355MP-A	1~230	1,9	2,5	SWITCHMATIC2	1 ½"	2"		
SW VERTI 454MP	1~230	1,5	2	SWITCHMATIC2	1 ½"	2"		
SW VERTI 455MP	1~230	2,2	3	SWITCHMATIC2	1 ½"	2"		
SW U5V-150/5	1~230	1,1	1,5	SWITCHMATIC2	1 ¼"	2"		
SW U5V-200/7	1~230	1,5	2	SWITCHMATIC2	1 ¼"	2"		
SW U7V-300/6	1~230	2,2	3	SWITCHMATIC2	1 ½"	2"		

GRUPOS PERSONALIZADOS

Consulte al comercial de su zona o póngase en contacto con nuestro dpto. técnico y pida presupuesto sin compromiso.



Disponible con electrobombas series Verti-P, Verti-I, Vertinox, CTV y Ultras V.

CON VARIADOR ABB

DESCRIPCIÓN

- Conjuntos automáticos para el suministro de agua a presión constante, controlados por variador de velocidad mural.
- Se fabrican los mismos modelos indicados en las tablas de características anteriores de grupos hidroneumáticos y para prestaciones superiores.
- Estos equipos **incluyen el acumulador de 25 litros** y el transductor de presión.



MODELO	P ₂		CUADRO		CONEXIONES	
	kW	Hp	AUTOMATISMO	ASPIRACIÓN	COLECTOR	
GV VERTI 304TP	1	1,35	VF ABB-580	1"	2"	
GV VERTI 306TP	1,5	2	VF ABB-580	1"	2"	
GV VERTI 308TP	2,2	3	VF ABB-580	1"	2"	
GV VERTI 354TP-A	1,5	2	VF ABB-580	1 ½"	2"	
GV VERTI 355TP-A	1,9	2,5	VF ABB-580	1 ½"	2"	
GV VERTI 356TP-A	2,2	3	VF ABB-580	1 ½"	2"	
GV VERTI 358TP-A	3	4	VF ABB-580	1 ½"	2"	
GV VERTI 554TP	2,2	3	VF ABB-580	1 ½"	2"	
GV VERTI 556TP	3	4	VF ABB-580	1 ½"	2"	
GV VERTI 557TP	4	5,5	VF ABB-580	1 ½"	2"	
GV VERTI 356TI	2,2	3	VF ABB-580	1 ½"	2"	
GV VERTI 358TI	3	4	VF ABB-580	1 ½"	2"	
GV VERTI 3510TI	4	5,5	VF ABB-580	1 ½"	2"	
GV VERTI 554TI	2,2	3	VF ABB-580	1 ½"	2"	
GV VERTI 556TI	3	4	VF ABB-580	1 ½"	2"	
GV VERTI 557TI	4	5,5	VF ABB-580	1 ½"	2"	
GV U7V-300/6	2,2	3	VF ABB-580	1 ¼"	2"	
GV U7V-400/8	3	4	VF ABB-580	1 ¼"	2"	
GV U9V-400/7	3	4	VF ABB-580	1 ½"	2"	
GV U9V-550/10	4	5,5	VF ABB-580	1 ½"	2"	
GV U18V-550/6	4	5,5	VF ABB-580	2"	2"	
GV U18V-750/8	5,5	7,5	VF ABB-580	2"	2"	

GRUPOS PERSONALIZADOS

Consulte al comercial de su zona o póngase en contacto con nuestro dpto. técnico y pida presupuesto sin compromiso.



Disponible con electrobombas series Verti-P, Verti-I, Vertinox, CTV y Ultras V.

CON VARIADOR SPEEDMATIC

DESCRIPCIÓN

- Los equipos de presión **SPEEDMATIC** con variación de frecuencia para viviendas individuales o colectivas mantienen una presión constante en el suministro de agua, ajustándola a la demanda en tiempo real, gracias a un variador de velocidad inline, de muy fácil programación.
- Estos grupos incluyen el acumulador.



*Funcionamiento de la bomba principal con variador de frecuencia y entrada directa en cascada en las bombas auxiliares, a pleno régimen.

MODELO	P ₂		CUADRO		CONEXIONES	
	kW	Hp	AUTOMATISMO	ASPIRACIÓN	COLECTOR	
GL VERTI 304TP	1	1,35	SET-X010	1"	2"	
GL VERTI 306TP	1,5	2	SET-X010	1"	2"	
GL VERTI 308TP	2,2	3	SET-X010	1"	2"	
GL VERTI 354TP-A	1,5	2	SET-X010	1 ½"	2"	
GL VERTI 355TP-A	1,9	2,5	SET-X010	1 ½"	2"	
GL VERTI 356TP-A	2,2	3	SET-X010	1 ½"	2"	
GL VERTI 554TP	2,2	3	SET-X010	1 ½"	2"	
GL VERTI 356TI	2,2	3	SET-X010	1 ½"	2"	
GL VERTI 554TI	2,2	3	SET-X010	1 ½"	2"	
GL U7V-300/6	2,2	3	SET-X010	1 ¼"	2"	

GRUPOS PERSONALIZADOS

Consulte al comercial de su zona o póngase en contacto con nuestro dpto. técnico y pida presupuesto sin compromiso.



Disponible con electrobombas series Verti-P, Verti-I, Vertinox, CTV y Ultras V.

ELEMENTOS DE MONTAJE

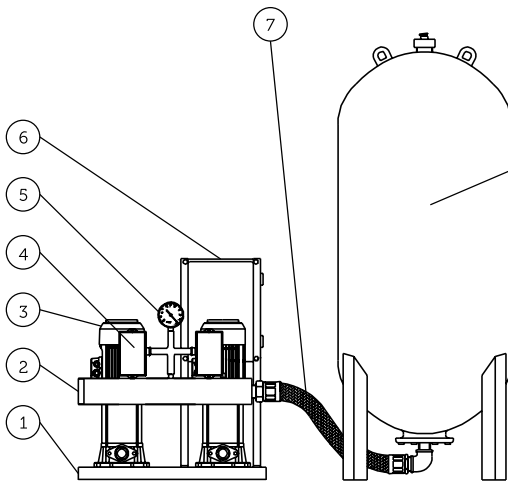

**GRUPO DE PRESIÓN DOBLE
HIDRONEUMÁTICO**

1. Bancada general
2. Colector común de impulsión
3. Bomba de servicio
4. Presostato
5. Manómetro
6. Cuadro de protección y maniobra alterna
7. Manguera flexible
8. Acumulador hidroneumático

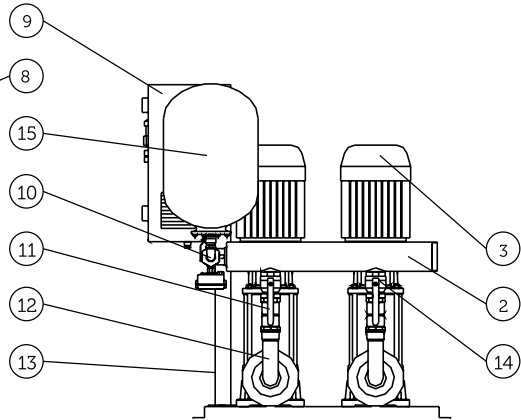

**GRUPO A PRESIÓN DOBLE
CON VARIADOR DE FRECUENCIA**

9. Variador de frecuencia
10. Transductor de presión diferencial
11. Llave de corte
12. Curva 90° impulsión
13. Soporte cuadro eléctrico/variador
14. Rácor 3 piezas
15. Acumulador 25/50 L

CAUDAL:

Calculado en base al coeficiente de simultaneidad detallado en el CTE, en base al consumo medio de viviendas tipo D (ver página anterior)

PRESIÓN DE ARRANQUE:

Altura geométrica + Pérdidas de carga totales de la instalación + Presión requerida en el punto más desfavorable.

PRESIÓN DE PARADA:

Presión de arranque + 15 m.

PRESIÓN MÍNIMA DE ARRANQUE:

Se obtiene añadiendo 15 m a la altura geométrica desde el nivel mínimo del agua o base de las bombas hasta el techo de la planta más alta que se tenga que alimentar, más las pérdidas de carga.

CAPACIDAD DE LOS DEPOSITOS DE EXPANSIÓN EN FUNCIÓN DE LOS CAUDALES Y PRESIONES

Para h geométrica máx. del edificio 10 m
P. arranque: 2,9 Kg - P. parada: 4,0 Kg

CAUDAL (m³/h)	DEP. MEMBRANA	DEPÓSITOS GALVANIZADOS	
	CAPACIDAD (litros)	CAPACIDAD (litros)	INYECTOR RECOMENDADO
5	100/8 bar	300/6 bar	Medio
6,5	150/8 bar	500/6 bar	Medio
8	200/8 bar	500/6 bar	Medio
10	200/8 bar	800/6 bar	Maior
12	250/8 bar	800/6 bar	Maior
14	300/8 bar	800/6 bar	Maior
16	350/8 bar	1.000/6 bar	Maior
18	350/8 bar	1.000/6 bar	Maior
20	500/8 bar	1.500/6 bar	Maior

Para h geométrica máx. del edificio 15 m
P. arranque: 3,0 Kg - P. parada: 4,5 Kg

CAUDAL (m³/h)	DEP. MEMBRANA	DEPÓSITOS GALVANIZADOS	
	CAPACIDAD (litros)	CAPACIDAD (litros)	INYECTOR RECOMENDADO
5	100/8 bar	300/6 bar	Medio
6,5	150/8 bar	500/6 bar	Medio
8	200/8 bar	500/6 bar	Medio
10	200/8 bar	800/6 bar	Maior
12	250/8 bar	800/6 bar	Maior
14	300/8 bar	1.000/6 bar	Maior
16	350/8 bar	1.000/6 bar	Maior
18	350/8 bar	1.000/6 bar	Maior
20	500/8 bar	1.500/6 bar	Maior

Para altura geométrica máx. del edificio 20 m
P. arranque: 4,0 Kg - P. parada: 5,0 Kg

CAUDAL (m³/h)	DEP. MEMBRANA	DEPÓSITOS GALVANIZADOS	
	CAPACIDAD (litros)	CAPACIDAD (litros)	INYECTOR RECOMENDADO
5	150/8 bar	500/6 bar	Medio
6,5	200/8 bar	500/6 bar	Medio
8	200/8 bar	800/6 bar	Maior
10	300/8 bar	800/6 bar	Maior
12	300/8 bar	1.000/6 bar	Maior
14	350/8 bar	1.000/6 bar	Maior
16	500/8 bar	1.500/6 bar	Maior
18	500/8 bar	1.500/6 bar	Maior
20	500/8 bar	1.500/6 bar	Maior
25	700/8 bar	2.000/6 bar	An

Para altura geométrica máx. del edificio 25 m
P. arranque: 4,5 Kg - P. parada: 6,0 Kg

CAUDAL (m³/h)	DEP. MEMBRANA	DEPÓSITOS GALVANIZADOS	
	CAPACIDAD (litros)	CAPACIDAD (litros)	INYECTOR RECOMENDADO
5	150/8 bar	500/6 bar	Medio
6,5	200/8 bar	500/6 bar	Medio
8	250/8 bar	800/6 bar	Maior
10	300/8 bar	800/6 bar	Maior
12	350/8 bar	1.000/6 bar	Maior
14	500/8 bar	1.500/6 bar	Maior
16	500/8 bar	1.500/6 bar	Maior
18	500/8 bar	1.500/6 bar	Maior
20	700/8 bar	2.000/6 bar	An
25	2 x 500/8 bar	2.000/6 bar	An

Para altura geométrica máx. del edificio 30 m
Presión arranque: 5,0 Kg - Presión parada: 6,5 Kg

CAUDAL (m³/h)	DEP. MEMBRANA	DEPÓSITOS GALVANIZADOS	
	CAPACIDAD (litros)	CAPACIDAD (litros)	INYECTOR RECOMENDADO
5	150/8 bar	500/8 bar	Medio
6,5	200/8 bar	800/8 bar	Maior
8	250/8 bar	800/8 bar	Maior
10	300/8 bar	1.000/8 bar	Maior
12	350/8 bar	1.000/8 bar	Maior
14	500/8 bar	1.500/8 bar	Maior
16	500/8 bar	1.500/8 bar	Maior
18	700/8 bar	1.500/8 bar	Maior
20	700/8 bar	2.000/8 bar	An
25	700/8 bar	2.500/8 bar	An
30	2 x 500/8 bar	2.500/8 bar	An

Para altura geométrica máx. del edificio 35 m
Presión arranque: 5,5 Kg - Presión parada: 7,0 Kg

CAUDAL (m³/h)	DEP. MEMBRANA	DEPÓSITOS GALVANIZADOS	
	CAPACIDAD (litros)	CAPACIDAD (litros)	INYECTOR RECOMENDADO
5	150/8 bar	500/8 bar	Medio
6,5	200/8 bar	800/8 bar	Maior
8	250/8 bar	800/8 bar	Maior
10	300/8 bar	1.000/8 bar	Maior
12	500/8 bar	1.000/8 bar	Maior
14	500/8 bar	1.500/8 bar	Maior
16	500/8 bar	1.500/8 bar	Maior
18	700/8 bar	2.000/8 bar	Maior
20	700/8 bar	2.000/8 bar	An
25	700/8 bar	2.500/8 bar	An
30	2 x 500/8 bar	3.000/8 bar	Man

Para altura geométrica máx. del edificio 40 m
Presión arranque: 6,5 Kg - Presión parada: 8,0 Kg

CAUDAL (m³/h)	DEP. MEMBRANA	DEPÓSITOS GALVANIZADOS	
	CAPACIDAD (litros)	CAPACIDAD (litros)	INYECTOR RECOMENDADO
5	200/8 bar	500/8 bar	Medio
6,5	250/8 bar	800/8 bar	Maior
8	300/8 bar	800/8 bar	Maior
10	350/8 bar	1.000/8 bar	Maior
12	500/8 bar	1.500/8 bar	Maior
14	500/8 bar	1.500/8 bar	Maior
16	700/8 bar	2.000/8 bar	Maior
18	700/8 bar	2.000/8 bar	Maior
20	700/8 bar	2.000/8 bar	An
25	2 x 500/8 bar	2.500/8 bar	An
30	2 x 500/8 bar	3.000/8 bar	An

Para altura geométrica máx. del edificio 45 m
Presión arranque: 7,0 Kg - Presión parada: 8,5 Kg

CAUDAL (m³/h)	DEP. MEMBRANA	DEPÓSITOS GALVANIZADOS	
	CAPACIDAD (litros)	CAPACIDAD (litros)	INYECTOR RECOMENDADO
5	200/10 bar	500/10 bar	Ran
6,5	250/10 bar	800/10 bar	An
8	300/10 bar	800/10 bar	An
10	350/10 bar	1.000/10 bar	An
12	500/10 bar	1.500/10 bar	An
14	500/10 bar	1.500/10 bar	An
16	700/10 bar	2.000/10 bar	An
18	700/10 bar	2.000/10 bar	An
20	700/10 bar	2.500/10 bar	An
25	2 x 500/10 bar	3.000/10 bar	Man
30	2 x 500/10 bar	4.000/10 bar	Man

DESCRIPCIÓN

- Grupo de presión monofásico para suministro de hidrocarburos a presión constante, provisto de presostato para presión máxima y mínima.
- Bomba volumétrica de **anillo líquido con rodete en estrella** que otorga a la bomba una notable capacidad aspirante.
- Cuerpo de bomba con extremidad de latón para reducir el riesgo de bloqueo.

MATERIALES

- Bancada con soporte: **Acero galvanizado**
- Cuerpo bomba: **Fundición y latón**
- Soporte de motor: **Fundición**
- Impulsor: **Latón**
- Eje: **Acero INOX 416**

ÁREA DE TRABAJO

- Temperatura máx. del líquido: **90°C**
- Grado de protección: **IP44**
- Aislamiento clase: **F**



MODELO	DN ø"	P ₂			I (A) 1~230V	CAUDAL						P.V.P. B
		kW	Hp	1~230V		m ³ /h	0,3	0,6	1,2	1,8	2,4	
GG-MD100	1	0,75	1,00	5,4	ALTURA DE CARGA EN METROS						1.296,00	
					53	48	37	25	13,5	9		

TRASIEGO DE GASÓLEO GGS

DESCRIPCIÓN

- Grupo de presión monofásico particularmente apropiado en las operaciones de trasiego para combustibles de baja viscosidad gasóleos o aceites muy ligeros y cualquier fluido compatible con los materiales construidos que desprendan gases.
- Acumulador hidroneumático de membrana de 8L.

MATERIALES

- Cuerpo bomba: **Fundición y latón**
- Eje: **Acero INOX 416**
- Soporte de motor: **Fundición**
- Impulsor: **Latón**
- Cierre mecánico: **Cer/Graf**
- Depósito: **Acero**

ÁREA DE TRABAJO

- Temperatura máx. del líquido: **90°C**
- Grado de protección: **IP44**
- Aislamiento clase: **F**
- Presión máx. de trabajo: **8 bar**
- Capacidad depósito: **8L**



MODELO	DN ø"	P ₂			I (A) 1~230V	CAUDAL						P.V.P. B
		kW	Hp	1~230V		m ³ /h	0	0,3	0,6	1,2	1,8	
GGS-MD100	1	0,74	1,00	5,4	ALTURA DE CARGA EN METROS						MONOF. 820,00	
					60	53	48	37	25	13,5		9



GRUPOS CONTRA INCENDIOS



PYD
ELECTROBOMBAS



GRUPOS CONTRA INCENDIOS

En Proindexsa, a través de nuestra marca **PYD System**, nos especializamos en la **fabricación de Grupos de Contra Incendios (GCI)** cumpliendo con diversas normativas vigentes.

Nuestro compromiso se basa en ofrecer un **asesoramiento personalizado**, brindando a cada cliente soluciones adaptadas a sus necesidades específicas desde nuestro **departamento de producción**. Disponemos de una amplia gama de productos, diseñados en conformidad con las últimas normativas y ajustándonos a los requerimientos particulares de cada instalación.

Gracias a este enfoque, garantizamos el **desarrollo de equipos fiables, eficientes y alineados con las normativas más exigentes del sector**.

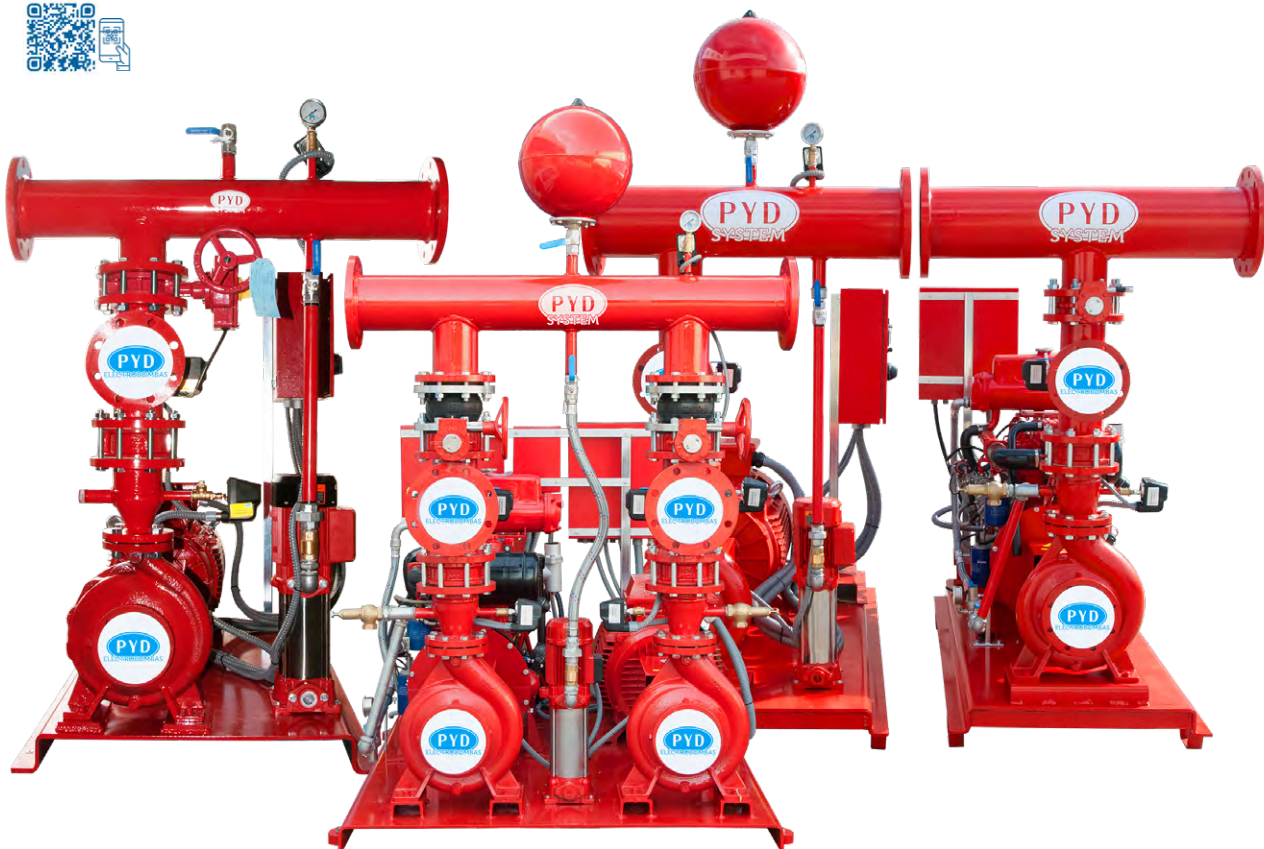



UNE 23-500/90 Y ANEXO C DE UNE 23-500/2012

DESCRIPCIÓN

Equipos de bombeo automáticos especialmente diseñados y contruidos para ofrecer la mejor solución en el suministro automático de agua a presión en una instalación de protección contra incendios bajo la normativa **UNE 23-500 del año 1990.**

ANEXO C 2012

Grupos contra incendios compuestos por una **bomba principal eléctrica y una bomba auxiliar jockey** destinados a abastecimientos sencillos con un caudal de **demanda máximo de 200 l/min**, exclusivamente para instalaciones de B.I.E. de 25 mm de diámetro, cumpliendo con el Anexo C de la normativa **UNE 23-500/2012.**

UNE 23-500/12, UNE 23-500/18, UNE 23-500/21 EN 12845 Y CEPREVEN

DESCRIPCIÓN

Equipos de bombeo automáticos especialmente diseñados y contruidos para ofrecer la mejor solución en el suministro automático de agua a presión en una instalación de protección contra incendios bajo las normativas **UNE 23-500/2012, UNE 23-500/2018, UNE 23-500/2021, UNE EN 12845 y CEPREVEN.**

CUADRO

Cuadros eléctricos montados en armario metálico de color rojo **RAL 3000 CC**, con interruptor general de corte, preparados para cumplir con todas las especificaciones técnicas de la norma certificada. Montados sobre soporte vertical, cableados y probados.

CONFIGURACIÓN

Cada grupo se compone de una bomba **Jockey** y una o **más bombas principales** que pueden ser **eléctrica o diésel**, de este modo las distintas configuraciones podrían ser las siguientes:

- Jockey + Eléctrica
- Jockey + Diésel
- Jockey + Eléctrica + Diésel
- Jockey + Diésel + Diésel
- Jockey + Eléctrica + Eléctrica (exclusivo para CEPREVEN R.T.2-ABA)

NOMENCLATURA

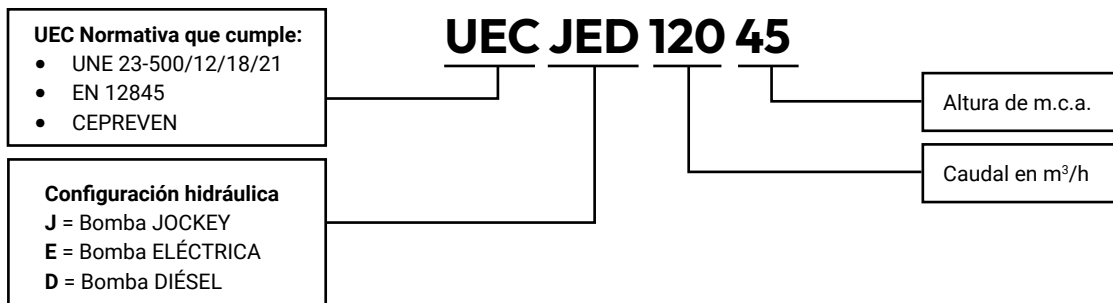

DOCUMENTACIÓN



Manual cuadro Jockey + Eléctrico



Manual cuadro Jockey



Manuales cuadro diésel



Manual cuadro cofre



Manual instrucciones GCI



Certificado CE



UNE 23-500/12, EN 12845 y CREPREVEN



UEC JE 120 60



UEC JD 120 70

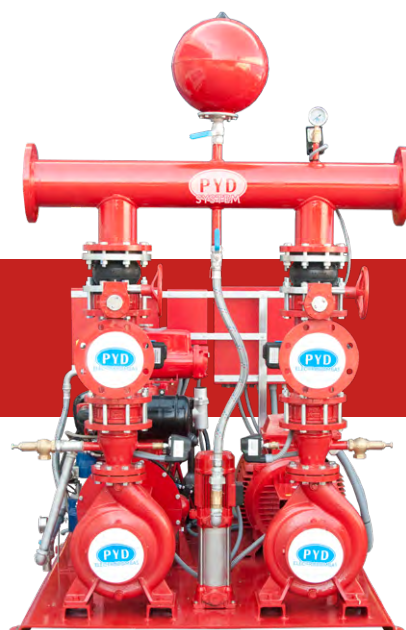

UEC JED 120 70



UEC JED 23 500



UEC JDD 120 70



GRUPOS CONTRA INCENDIOS

UNE 23-500/90 y ANEXO C - UNE 23-500/18 S



U90 JE 24 60



U90 JD 12 60



U90 JED 12 65



U18 JD 12 60



U18 JE 12 60



DEPÓSITO DE CEBADO

DESCRIPCIÓN

- Depósitos de polietileno para cebado de bombas principales en Grupos Contra Incendios según normativa UNE 23-500.

CARACTERÍSTICAS

- Incluye racord de salida.
- Sensor de nivel de agua.
- Válvula de retención.
- Válvula de corte.

MATERIALES

- Cuerpo y tapa fabricado en polietileno lineal, aditivado anti-UV.

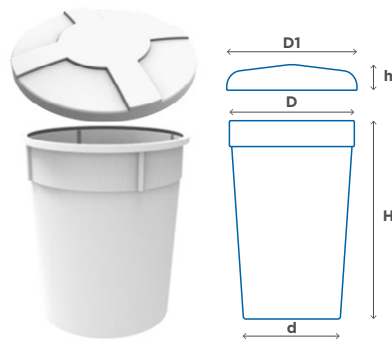

CAPACIDAD (L)	DIMENSIONES					P.V.P.
	D1	D	d	H	h	
130*	610	600	530	650	50	Consulte precios con nuestro dpto. comercial
200	670	650	500	890	130	
500	920	880	720	1.100	145	

(*) Modelo de dimensiones cilíndricas. Resto en dimensiones cónicas.

CAUDAL (m ³ /h)	SELECCIÓN SEGÚN NORMATIVAS			
	UNE 23-500:2012	UNE 23-500:2018	UNE 23-500:2021	EN 12845
Qn ≤ 36	500*	100	100	500
36 < Qn ≤ 120	500*	500	500	500
Qn > 120	500*	500	500	500

CAUDALÍMETROS

DESCRIPCIÓN

- Amplia gama de modelos para pequeños, medios y grandes caudales. Aptos para mediciones de líquidos.
- **Serie OP:** Solo permite instalación de tubería horizontal
- **Serie T:** Pueden ser instalados en posición horizontal o vertical, con independencia del sentido de circulación.

MATERIALES

- Tubo medidor: **Polisulfón o policarbonato irrompible.**
- Para mediciones de gases y líquidos
- Fácil mantenimiento
- Alta calidad certificada



MODELO	DN	RANGO MÁX.	CAUDAL	P.V.P
	"	m ³ /h	m ³ /h	
T-50-22	2	22	12	Consulte precios con nuestro dpto. comercial
T-50-40	2	40	24	
T-65-60	2 ^{1/2}	60	36	
T-100-120	4	120	72	
T-100-150	4	150	84	
T-150-300	6	300	180	
T-200-500	8	500	270	
T-200-500	8	500	300	

MODELO	DN	RANGO MÁX.	CAUDAL	P.V.P
	"	m ³ /h	m ³ /h	
OP-50-35	2	35	18	Consulte precios con nuestro dpto. comercial
OP-65-54	2 ^{1/2}	54	30	
OP-80-70	3	70	42	
OP-80-95	3	95	48	
OP-100-110	4	110	60	
OP-100-180	4	180	90	
OP-125-220	5	220	120	
OP-125-300	5	300	150	
OP-150-400	6	400	210	
OP-150-400	6	400	240	



BATERÍA DE DEPÓSITOS PARA ALIMENTACIÓN

DESCRIPCIÓN

- Batería de **4 depósitos** de 12.000L (3.000L cada ud.) para reserva de agua de Grupos Contra Incendios con colector de aspiración.
- Conectados mediante sus correspondientes kits de unión incluidos.

CARACTERÍSTICAS

- Fabricados en **polietileno de alta densidad**.
- Fácil instalación.
- Para sistemas de extinción de incendios de BIEs de 25 mm.

NORMATIVAS

- Apto para aplicaciones con **normativa UNE 23-500/12 (Anexo C)** de Grupos Contra Incendios.



Opcional: Envío directo a obra/instalación

ESPECIFICACIONES

VOLÚMEN	LONGITUD	ANCHURA	ALTURA	P.V.P.
L	mm	mm	mm	
12.000	1.725	4.753	1.850	4.175,00

REDUCCIÓN EXCÉNTRICA

DESCRIPCIÓN

- Componente de tubería para disminuir el diámetro.
- Enfocado para reducir las bolsas de aire en los Grupos Contra Incendios.

MATERIALES

- Fabricado en hierro
- Pintado en RAL 3000 (según normativa)

NORMATIVAS

- UNE 23-500/12
- UNE 23-500/18
- UNE 23-500/21

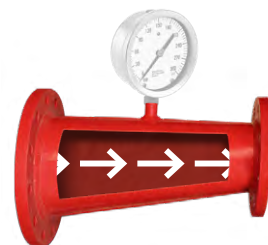

	DN ASPIRACIÓN		P.V.P.
DN65 (2½")	➔	DN50 (2")	287,00
DN80 (3")	➔	DN50 (2")	304,00
DN100 (4")	➔	DN50 (2")	329,00
DN80 (3")	➔	DN65 (2½")	304,00
DN100 (4")	➔	DN65 (2½")	329,00
DN150 (6")	➔	DN65 (2½")	385,00
DN100 (4")	➔	DN80 (3")	329,00
DN150 (6")	➔	DN80 (3")	385,00
DN200 (8")	➔	DN100 (4")	471,00
DN200 (8")	➔	DN125 (5")	471,00
DN250 (10")	➔	DN125 (5")	594,00
DN200 (8")	➔	DN150 (6")	471,00
DN250 (10")	➔	DN150 (6")	594,00
DN300 (12")	➔	DN150 (6")	736,00



GRUPOS CONTRA INCENDIOS

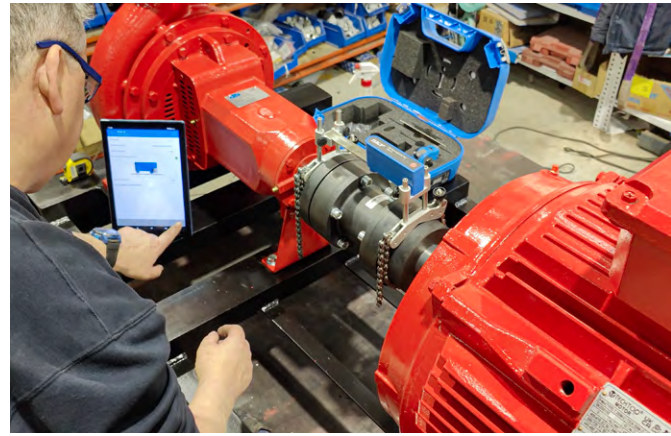



USO SANITARIO



ELECTROBOMBA SANITARIA INOX SERIES LATTEA Y TURBO

DESCRIPCIÓN

- Bombas centrífugas sanitarias fácilmente desmontables sin ayuda de herramientas para una inspección y mantenimiento rápidos y sencillos.
- Diseñadas para garantizar la higiene de los líquidos tratados.

MATERIALES

- Disponibles con cubierta inoxidable en **AISI 304** para el motor.
- Suministrables asimismo con trípode.
- Orificios de aspiración e impulsión roscados según **DIN 11851**.

APLICACIONES

- Industrias enológica
- Alimentaria
- Química
- Cosmética
- Farmacéutica.



SERIE TURBO



MODELO	CONEXIONES (mm)		P ₂		MOTOR R.P.M.
	ENTRADA	SALIDA	kW	Hp	
LATTEA 200	25	25	0,20	0,35	1.400
	25	25	0,75	1,00	2.800
LATTEA 300	40	25	1,10	1,50	1.400
	40	25	2,25	3,00	2.800
LATTEA 500	50	40	2,25	3,00	1.400
	50	40	4,10	5,50	2.800
LATTEA 1000	65	65	2,25	3,00	1.400
	65	65	5,60	7,50	2.800
STAR LATTEA	50	50	2,25	3,00	1.400
	50	50	3,00	4,00	2.800
	50	50	5,25	7,00	2.800
TURBO 2	-	-	0,65	0,90	2.800

	CAUDAL								P.V.P.
	H = ALTURA mts.				Q = CAUDAL l/min				
	0	1	2	3	3,5	4			
H	0	1	2	3	3,5	4			
Q	110	90	75	55	40	10			1.814,00
H	5	8	10	12	15	16			
Q	200	175	150	135	60	0			1.814,00
H	0	2	4	5	6				
Q	240	210	150	110	0				2.165,00
H	5	10	15	20	25	26			
Q	360	310	260	200	80	0			2.165,00
H	0	2	4	6	8	10	11	12	
Q	720	710	640	570	500	380	290	0	2.548,00
H	5	10	15	20	25	30	33		
Q	700	600	500	400	280	80	0		2.548,00
H	0	2	4	6	8	10	12	13	
Q	900	850	800	600	410	240	100	0	3.187,00
H	5	10	15	20	25	30	35	38	
Q	800	680	600	500	340	170	60	0	3.464,00
H	0	2,5	5	7,5					
Q	400	300	270	150					2.936,00
H	2	5	10	15	20	25	28	30	
Q	820	770	650	540	410	230	100	MÁX	2.936,00
H	2	5	10	15	20	25	30	34	35
Q	930	900	880	850	700	540	350	150	MÁX
H	0	2	5	8					
Q	240	200	100	25					620,00

SUPLEMENTOS

SERIE LATTEA	P.V.P.
Cubierta INOX + Trípode LT200	484,00
Cubierta INOX + Trípode LT300	515,00
Cubierta INOX + Trípode LT500	638,00
Cubierta INOX + Trípode LT1000 (3HP)	658,00
Cubierta INOX + Trípode LT1000 (7,5HP)	667,00

STAR LATTEA	P.V.P.
Cubierta + Trípode 3,00-4,00 CV	475,00
Cubierta + Carrito 3,00-4,00 CV	484,00
Cubierta + Trípode 7,50 CV	872,00
Cubierta + Carrito 7,50 CV	884,00



ELECTROBOMBA SANITARIA SERIE EP

DESCRIPCIÓN

- Electrobombas autoaspirantes en acero inoxidable con impulsor flexible (para tensión trifásica, tensión monofásica bajo demanda).
- Motor con interruptor e inversor de giro, provisto con 6 metros de cable (excepto en modelo MAXI 80).

MATERIALES

- Modelos MINI y MIDEX en acero inoxidable **AISI 316**, resto de modelos en **AISI 304**.
- Cierre mecánico estándar en **INOX/Graf/NBR**.
- Impulsor en **goma natural NR**.
(Bajo demanda: nitrilo, neopreno, EPDM, silicona)

APLICACIONES

- Industrias enológica
- Alimentaria
- Química
- Cosmética
- Farmacéutica.



MINOR - MAJOR - MAXI



MINI - MIDEX



MODELO	P ₂		MOTOR	N°	PESO
	kW	Hp			
EP MINI ¾	0,37	0,50	900	1	9,3
	0,55	0,75	1.400	1	9,0
	0,55	0,75	900	1	15,0
EP MIDEX 1 ¼	0,75	1,00	1.400	1	15,0
	0,56 ~ 0,37	0,75 ~ 0,50	1.400 ~ 700	2	15,0
EP MINOR 40	1,50	2,00	900	1	20,0
	1,50	2,00	1.400	1	20,0
	2,10 ~ 1,20	2,80 ~ 1,60	1.400 ~ 900	2	27,0
EP MAJOR 60	1,25	1,70	470	1	38,0
	1,50	2,00	700	1	31,0
EP MAXI 80	1,87	2,50	900	1	31,0
	3,30	4,50	470	1	68,0
EP MAXI 80	3,50	4,70	600	1	68,0

F	ALTURA DE CARGA EN METROS										P.V.P.
	0	4	8	12	16	18	24	27	30	32	
	CAUDAL (m³/h)										
1	0,9	0,9	0,7	0,5	0,5	0					870,00
1,6	1,4	1,3	1,1	1	0,9	0,6	0,4	0,2	0		823,00
3,8	3,5	3,2	2,8	2,2	1,8	0,7	0				1.351,00
5,8	5,2	4,8	4,3	3,6	3,2	1,9	1,2	0			1.297,00
5,8	5,2	4,8	4,3	3,6	3,2	1,9	1,2	0			1.478,00
6,9	6,2	5,8	5	4,2	3,7	1,8	0				1.646,00
10	9	8	6,9	5,5	4,9	2,6	1,7	0			1.646,00
10	9	8	6,9	5,5	4,9	2,6	1,7	0			2.500,00
12	10,5	8,7	5,1	0							3.244,00
18	15	12	8,4	2,5	0						2.453,00
22,5	19,6	15	11,2	3	0						2.595,00
36	34,2	30	24	12	0						4.699,00
43,8	41,4	36	30	16	0						4.699,00

RACCORES	P.V.P.
Raccord portamangueras EP MINI 3/4" x 20	72,00
Raccord portamangueras EP MIDEX 1 ¼" x 25	93,00
Raccord portamangueras EP MIDEX 1 ¼" x 30	93,00
Reducción 1 ¼" GAS-FX40 EP MIDEX	60,00

IMPULSOR FLEXIBLE

Los principales beneficios del sistema de rodete flexible:

- **Autoaspirante:** Aspiración del producto hasta 9 metros, incluso en seco.
- **Reversible:** Funciona en ambas direcciones de rotación, permitiendo el reflujo del exceso sin intervención manual y el vaciado al final de la operación.
- **Rendimiento** excelente incluso a bajas revoluciones, que permite la transferencia de fluidos con viscosidades de hasta 50.000 cp y con partículas sólidas en suspensión sin airear, emulsionar o dañar el líquido.
- Trasiego del fluido **sin pulsaciones**, con una velocidad de flujo constante, ideal para dosificación, llenado y filtración.
- Funcionamiento en **cualquier posición**.

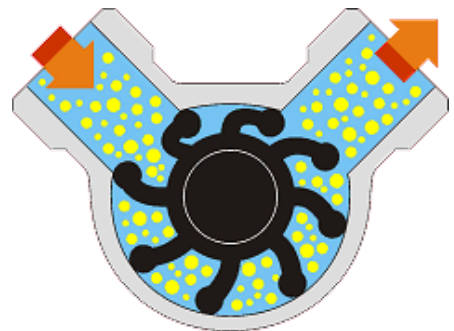

ELECTROBOMBA SANITARIA SERIE EP - INOX 316

DESCRIPCIÓN

- Electrobombas de anillo líquido, autocebantes y reversibles.
- Adecuadas para el trasvase de líquidos claros, sin partes sólidas en suspensión.

MATERIALES

- Modelos en acero inoxidable **AISI 316**,
- Cierre mecánico estándar en **INOX/Graf/NBR**.
- Impulsor en **acero INOX**
(Bajo demanda: nitrilo, neopreno, EPDM, silicona)

APLICACIONES

- Industrias enológica
- Alimentaria
- Química
- Cosmética
- Farmacéutica



MODELO	P ₂		MOTOR R.P.M.	PESO Kg
	kW	Hp		
EPH NEOS 3/4"	0,22	0,30	2.800	5,5
EP NEOS 3/4"	0,22~0,26	0,3~0,35	2.800	5,1
EP JUNIOR 1"1/4	0,45~0,56	0,6~0,75	2.800	9,3
EP SENIOR 1"1/2	0,75~1	1~1,35	1.400	19,9
EP MASTER 2"	1,87	2,50	1.400	35,5
EP 60 INOX	4,0	5,4	1.400	42,0
EP 70 INOX	5,5~7,5	7,4~10	1.400	87,0
EP 80 INOX	15	20	1.400	216,0

ALTURA DE CARGA EN METROS										
	0	5	10	15	18	22	30	35	40	50
CAUDAL (m ³ /h)										
	1,74	1,5	1,1	0,7	0,5	0				
	1,74	1,5	1,1	0,7	0,5	0				
	3,5	2,8	2	1,3	0,8	0				
	7,2	6,3	5,1	3,7	2,7	0				
	13,8	12,3	10,5	8,4	7,2	4,8	0			
	21	18,6	15,9	13,2	11,4	9	3,6	0		
	30	27,3	24,9	21,9	19,8	16,8	9,9	5,4	0	
	54	50,4	46,8	43,2	39,6	37,2	30	24,6	18,6	6,6

Consulte P.V.P.

I: Modelo con regulador de velocidad. Cable de 2 m con conexión schuko para monofásica / cable de 4 m para trifásica.

L: Modelo monofásico con cable de 2 m y conexión schuko.

M: Modelo con caja de bornes.



ANILLO LÍQUIDO

- El anillo líquido en una bomba sanitaria es un componente crucial diseñado para crear un **sello hermético** entre las cámaras de presión y succión de la bomba. Cuando la bomba está en funcionamiento, este anillo líquido se mueve junto con el impulsor, formando un sello continuo que **evita la fuga de líquido y la entrada de aire** o contaminantes externos al sistema.



Su función de sellado también contribuye a la **lubricación y enfriamiento del impulsor**, ayudando así a mantener un rendimiento óptimo y una larga vida útil de la bomba.

Fabricado con líquidos compatibles con los estándares sanitarios, como agua o soluciones limpiadoras.

ELECTROBOMBA SANITARIA SERIE EP - BRONCE

DESCRIPCIÓN

- Electrobombas de anillo líquido, autocebantes y reversibles.
- Fabricadas en bronce son especialmente valoradas por su resistencia a la corrosión como agua de mar, dulce, gasóleo, etc.

MATERIALES

- Modelos en **Bronce**,
- Cierre mecánico estándar en **INOX/Graf/NBR**.
- Impulsor en **bronce**
(Bajo demanda: nitrilo, neopreno, EPDM, silicona)



APLICACIONES

- Náutica
- Agrícola
- Química
- Cosmética
- Farmacéutica



MODELO	P ₂		MOTOR	PESO	ALTURA DE CARGA EN METROS																	
	kW	Hp			R.P.M.	Kg	0	5	10	12	15	18	22	24	30	35	40					
EPH 20	0,22	0,30	2.800	5,5	1,7	1,2	0,6	0,4	0													
EPH 25	0,45	60	2.800	9,2	3,6	2,8	1,8	1,4	0,7	0												
EP 20	0,22~0,26	0,30~0,35	2.800	5,9	1,7	1,2	0,6	0,4	0													
EP 25	0,45~0,56	0,60~0,75	2.800	9,8	3,6	2,8	1,8	1,4	0,7	0												
EP 30	0,75	1	1.400	13,5	4,5	3,6	2,4	1,8	0,9	0												
EP40	0,75~1	1~1,3	1.400	19,8	7,2	6,3	5,1	4,8	3,7	2,7	0											
EP 50	1,9	2,5	1.400	13,5	13,8	12,3	10,5	9,6	8,4	7,2	4,8	3,6	0									
EP 70	5,5~7,5	7,3~10	1.400	19,8	30	27,3	24,9	23,4	21,9	19,8	16,8	15,3	9,9	5,4	0							

Consulte P.V.P.

Los modelos EPH 20, EPH 25, EP 20 llevan la manilla incluida. Los modelos EP 25, EP 30 y EP 40 la manilla está disponible bajo demanda. Resto de modelos no incluye manilla.

APLICACIONES



MOTORREDUCTOR SERIE RID

DESCRIPCIÓN

- Electrobombas con motorreductor para tensión trifásica en acero inoxidable **AISI 304**.

MATERIALES

- Cierre mecánico estándar en **INOX/Graf/NBR**.
- Impulsor en goma **natural NR** (bajo demanda nitrilo, neopreno, EPDM, silicona)



APLICACIONES

- Náutica
- Agrícola
- Química
- Cosmética
- Farmacéutica



MODELO	P ₂		MOTOR R.P.M.	N° VELOC.	PESO Kg	ALTURA DE CARGA EN METROS					P.V.P.	
	kW	Hp				0	4	12	16	18		20
RID MINOR 40	1,5	2,0	350	1	38	CAUDAL (m³/h)						
	1,5	2,0	700	1	38	2,75	2,5	1,6	0,8	0	3.944,00	
	2,2	3,0	700	2	38	5,0	4,7	3,7	3,0	2,5	1,8	3.944,00
	1,5	2,0	350	2	38	5,0	4,7	3,7	3,0	2,5	1,8	4.105,00
RID MAJOR 60	2,2	3,0	470	1	48	2,75	2,5	1,6	0,8	0	4.105,00	
	2,2	3,0	700	1	48	12,0	10,5	5,1	0		4.537,00	
	2,2	3,0	700	1	48	18,0	15,0	8,4	2,5	0	4.537,00	
	2,2	3,0	470	2	48	12,0	10,5	5,1	0		4.698,00	
	1,5	2,0	235	2	48	6,3	5,1	0			4.698,00	
	2,2	3,0	700	2	48	18,0	15,0	8,4	2,5	0	4.698,00	
RID MAXI 80	1,5	2,0	350	2	48	9,0	7,8	3,7	0		4.698,00	
	4,0	5,5	470	1	79	36,0	24,2	24,0	12,0	0	6.170,00	
	4,0	5,5	600	1	79	43,8	41,4	30,0	16,0	0	6.170,00	
	4,5	6,0	470	2	79	36,0	24,2	24,0	12,0	0	6.638,00	
	3,3	4,5	235	2	79	19,2	18,0	9,6	0		6.638,00	
	4,5	6,0	600	2	79	43,8	41,4	30,0	16,0	0	6.638,00	
	3,3	4,5	300	2	79	24,6	22,2	12,0	0		6.638,00	

CARRITOS DE ACERO

SERIE RID
Modelo MINI
Modelo MIDEX
Modelo MINOR
Modelo MAJOR
Modelo MAXI

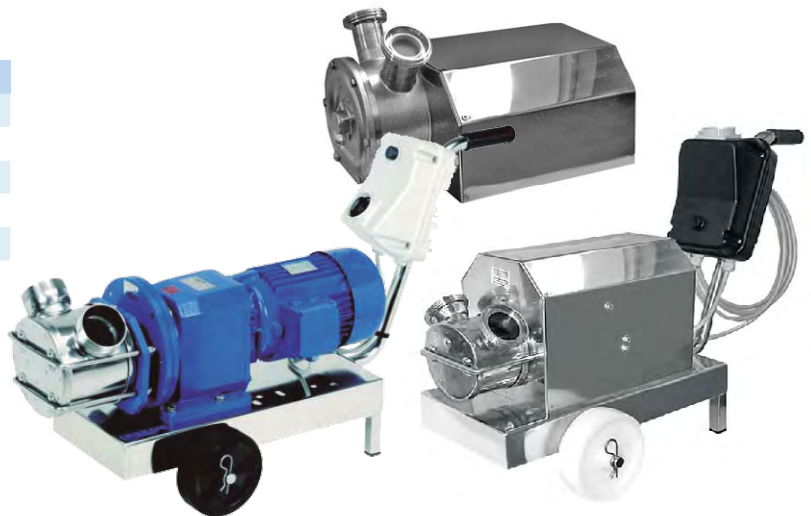

Cuadros eléctricos no incluidos en el carrito. Solicite más información.



ENGRANAJES



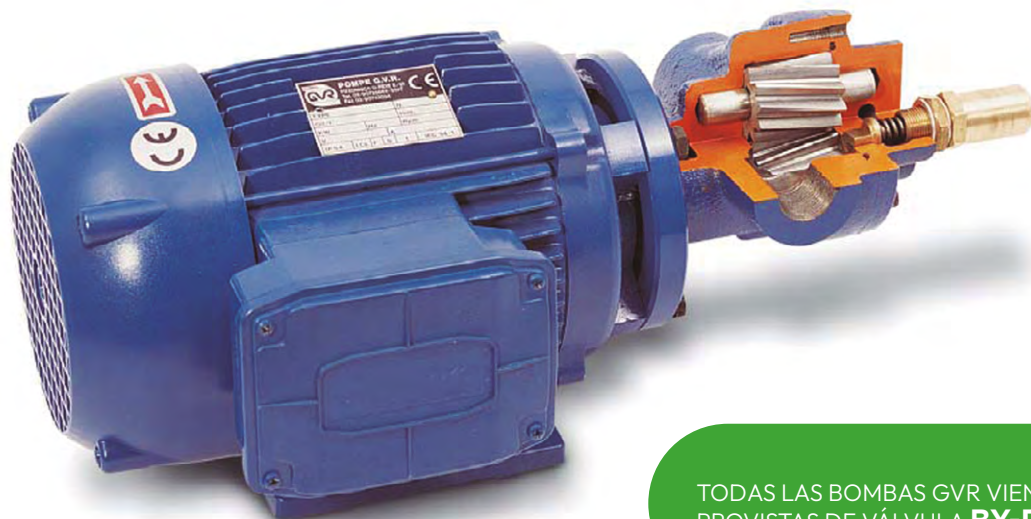

TODAS LAS BOMBAS GVR VIENEN PROVISTAS DE VÁLVULA **BY-PASS**

TABLA INDICATIVA DE LA VELOCIDAD RESPECTO A LA VISCOSIDAD

R.P.M.	1.500	1.000	750	600	500	400	300	200	100
Cst	300	600	1.000	2.000	3.200	6.000	10.000	20.000	30.000
°Engler	39,4	78,9	131,6	240	400	800	1.300	2.500	4.000

Para una correcta selección de la bomba es indispensable conocer:



- Tipo de líquido a tratar
- Temperatura
- Viscosidad
- Caudal necesario
- Altura de elevación
- Peso específico
- Altura de aspiración

DOBLE VALVULA BY-PASS

- Las bombas de la serie BMF se pueden suministrar con **doble válvula by-pass**, cierre mecánico reversible y doble sentido de giro, de modo que la bomba se convierte en **reversible**.
- El interruptor para el cambio de sentido de rotación es opcional (consulte suplementos).

SUPLEMENTO DOBLE BY-PASS

MODELOS	F
BMF5 - BMF25	
BMF35 - BMF70	

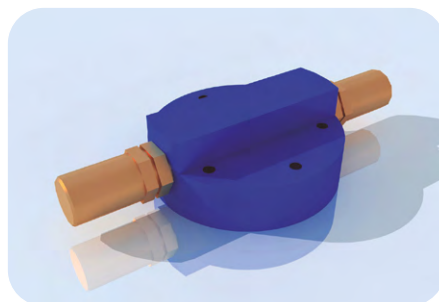

NOMENCLATURA

BMF
└──────── Trifásico

BCF
└──────── Monofásico

V = con válvula by-pass

X = Inoxidable

Z = Bonce

BOMBAS DE ENGRANAJES MONOBLOC SERIE BMF

DESCRIPCIÓN

- Bombas volumétricas de engranajes monobloc adecuadas para la transferencia de **líquidos viscosos** sin sólidos en suspensión.
- La válvula by-pass es de tipo recirculación interna y se puede parar rodando el tornillo de regulación.

MATERIALES

- Ejecución estándar bombas BMF: **Fundición**
- Ejes y engranajes: **Acero tratado**
- Cierre mecánico: **Vitón**
- BMFZ: **Bronce**
- BMFX: **Acero INOX AISI 316**



ÁREA DE TRABAJO

- Bombeo de aceite combustible, productos petrolíferos, cosméticos, alimentarios, barnices, aceites, lubricantes, grasas, betunes, melazas, etcétera.
- Temperatura máx. del líquido (modelo estándar): **120°C**.
- Aislamiento clase: **F**
- Grado de protección: **IP55**



MODELO	P ₂ Hp	P.V.P. ^F
BMF2	0,12	Consulte precios con nuestro dpto. comercial
BMF2M	0,18	
BMF3	0,18	
BMF3M	0,25	
BMF4	0,25	
BMF5	0,35	
BMF5M	0,35	
BMF10	0,35	
BMF10M	0,50	
BMF15	0,50	
BMF15M	0,75	
BMF25	0,75	
BMF25M	1,00	

MODELO	P ₂ Hp	P.V.P. ^F
BMF35	1,00	Consulte precios con nuestro dpto. comercial
BMF35M	1,50	
BMF50	1,50	
BMF50M	2,00	
BMF60	2,00	
BMF60M	2,50	
BMF5/6	0,25	
BMF10/6	0,35	
BMF15/6	0,50	
BMF25/6	0,75	
BMF35/6	1,00	
BMF50/6	1,50	
BMF60/6	1,50	

Las bombas terminadas en /6 son con motores de 6 polos (900 r.p.m.)
Ver suplementos por doble válvula by-pass en la página anterior.

RENDIMIENTOS PARA VISCOSIDAD 6°E

MODELO	1400 r.p.m.				900 r.p.m.	
	A 50 m DE ALTURA		A 100 m DE ALTURA (M)		A 100 m DE ALTURA (/6)	
	CAUDAL (l/hora)	POTENCIA (Hp)	CAUDAL (l/hora)	POTENCIA (Hp)	CAUDAL (l/hora)	POTENCIA (Hp)
BMF2	120	0,12	90	0,18	-	-
BMF3	210	0,18	160	0,25	-	-
BMF4	240	0,25	210	0,25	-	-
BMF5	320	0,35	300	0,35	200	0,25
BMF10	600	0,35	580	0,50	400	0,35
BMF15	900	0,50	850	0,75	600	0,50
BMF25	1.500	0,75	1.400	1,00	1.000	0,75
BMF35	2.100	1,00	2.000	1,50	1.400	1,00
BMF50	3.000	1,50	2.900	2,00	2.000	1,50
BMF60	3.600	2,00	3.400	2,50	2.400	1,50

BOMBAS DE ENGRANAJES SOBRE BANCADA SERIE B

DESCRIPCIÓN

- Bombas volumétricas autoaspirantes de engranajes sobre bancada adecuadas para la transferencia de líquidos viscosos sin sólidos en suspensión.

MATERIALES

- Bombas del tipo B: **Fundición**
- BZ: **Bronce**
- BX: **Acero INOX AISI 316 en ejecución sobre bancada con motor IE2.**

ÁREA DE TRABAJO

- Bombeo de líquidos viscosos (aceite combustible, productos petrolíferos, cosméticos, alimentarios, barnices, aceites, lubricantes, grasas, etc.) con viscosidades desde 1 hasta 700°E.
- Temperatura máx. del líquido (modelo estándar): **120°C.**

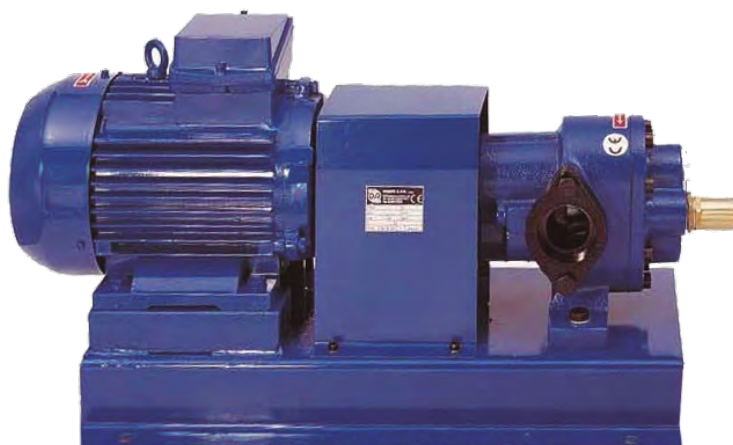

RENDIMIENTOS PARA VISCOSIDAD 6°E A 1.400 RPM

MODELO	DN	25 m	50 m	75 m	100 m	POTENCIA A INSTALAR (Hp)		P.V.P.
	Ø"	CAUDAL (l/min)				HASTA 50 m	HASTA 100 m	
B3	1/2	4,1	3,8	3,6	3,2	0,25	0,25	Consulte precios con nuestro dpto. comercial
B5	1/2	6,0	5,8	5,6	5,2	0,25	0,35	
B10	3/4	12,0	11,8	11,6	11,0	0,35	0,50	
B15	3/4	17,5	17,0	16,8	16,0	0,50	0,75	
B25	3/4	25,0	24,8	24,0	22,0	0,75	1,00	
B40	1	43,0	42,6	41,1	40,0	1,00	1,50	
B50	1 ½	54,0	52,0	51,0	50,0	1,50	2,00	
B70	1 ½	74,0	72,0	71,0	70,0	3,00	3,00	
B100	2	120	115	110	105	3,00	4,00	
B150	2	170	164	160	156	4,00	5,50	
B200	2 ½	215	212	208	205	5,50	7,50	
B250	2 ½	260	258	255	250	5,50	10,00	
B300	2 ½	320	314	306	302	7,50	10,00	
B350	2 ½	370	365	358	350	7,50	15,00	
B400	2 ½	420	415	410	405	10,00	15,00	
B450	3	475	468	460	455	10,00	15,00	
B500	3	525	515	510	505	15,00	20,00	
B550	3	565	560	550	545	15,00	20,00	
B600	3	630	620	610	600	15,00	20,00	

BOMBAS DE ENGRANAJES A EJE LIBRE SERIE B

DESCRIPCIÓN

- Bombas volumétricas autoaspirantes de engranajes con eje libre y campana de acoplamiento a motores forma B3/B14.

MATERIALES

- Bomba: **Fundición**
- Ejes y engranajes: **Acero tratado**

ÁREA DE TRABAJO

- Bombeo de líquidos viscosos sin sólidos en suspensión. Rango de líquidos con viscosidades desde 1 hasta 700°E.
- Temperatura máx. del líquido (modelo estándar): **120°C**.



MODELO	RENDIMIENTOS PARA VISCOSIDAD 6°E A 720 RPM								P.V.P. F
	10 m		20 m		30 m		50 m		
	Q (l/m)	kW abs.*	Q (l/m)	kW abs.*	Q (l/m)	kW abs.*	Q (l/m)	kW abs.*	
B1500	4,1	6,75	3,8	7,50	3,6	8,25	3,2	9,75	CONSULTAR
B2000	12,0	7,90	11,8	9,00	11,6	9,75	11,0	13,8	

* La potencia a instalar debe ser un 20% superior a la indicada como absorbida.

BOMBAS DE ENGRANAJES: MONTAJES

Bancada, acoplamiento elástico y motor eléctrico para determinar precio del grupo electrobomba, según modelos.

MODELOS EJECUCIONES Y TAMAÑOS	POTENCIA MOTOR (Hp)	R.P.M. MOTOR	P.V.P. F
B (Fundición) - BZ (Bronce) - BX (Inox) 3-5-10-15-25-30-40 IFXP (Inox) - IFZP (Bronce) 5-10-15-25	0,25	1.400	Consulte precios con nuestro dpto. comercial
	0,35		
	0,50		
	0,75		
	1,00		
B (Fundición) - BZ (Bronce) - BX (Inox) 50-70	1,50	1.400	
	2,00		
	3,00		
B (Fundición) - BZ (Bronce) - BX (Inox) 100-150	3,00	1.400	
	4,00		
	5,50		
B (Fundición) - BZ (Bronce) - BX (Inox) 200-250-300	5,50	1.400	
	7,50		
	10,00		
B (Fundición) - BZ (Bronce) - BX (Inox) 350-400-450	7,50	1.400	
	10		
	15		
B (Fundición) - BZ (Bronce) - BX (Inox) 500-550-600	15	1.400	
	20		
	10		
B (Fundición) 1500-1800-2000	15	720	
	20		
APF 5-10-15-25-30-40-50-60 Solamente motores eléctricos	0,35	1.400	
	0,50		
	0,75		
	1,00		
	1,50		
	2,00		
	3,00		
	4,00		

BOMBAS DE ENGRANAJES A EJE LIBRE SERIE APF

DESCRIPCIÓN

- Bombas volumétricas autoaspirantes de engranajes con eje libre y campana de acoplamiento a motores forma B3/B14.

MATERIALES

- APF: **Fundición**
- Ejes y engranajes: **Acero tratado**
- APFZ: **Bronce**
- APFX: **Acero INOX AISI 316**

ÁREA DE TRABAJO

- Bombeo de líquidos viscosos sin sólidos en suspensión. Rango de líquidos con viscosidades desde **1 hasta 700°E**.
- Temperatura máx. del líquido (modelo estándar): **120°C**.



RENDIMIENTOS PARA VISCOSIDAD 6°E A 1.400 RPM

MODELO	DN	HASTA 10 ATM.		HASTA 20 ATM.	
		CAUDAL (l/hora)	POTENCIA (Hp)	CAUDAL (l/hora)	POTENCIA (Hp)
APF5	1/2	300	0,35	250	0,50
APF10	3/4	600	0,50	540	1,00
APF15	3/4	900	0,75	720	1,50
APF25	3/4	1.500	1,00	1.300	2,00
APF30	1	1.800	1,50	1.600	3,00
APF40	1	2.400	1,50	2.100	3,00
APF50	1 ¼	3.000	2,00	2.800	4,00
APF60	1 ¼	3.600	3,00	2.600	5,50

P.V.P.

Consulte precios con nuestro dpto. comercial

SERIE IF

DESCRIPCIÓN

- Bombas volumétricas autoaspirantes de engranajes en ejecución sobre eje libre, aptas para su acoplamiento a motores B3/B14.

MATERIALES

- SERIE IFZ:
 - Cuerpo y cubiertas: **Bronce**
 - Engranajes y ejes: **Acero INOX AISI 316**

ÁREA DE TRABAJO

- Adecuadas para la transferencia de líquidos incluso con viscosidad de 1°E como el agua.



SERIE IFX:

- Completamente en acero inoxidable AISI 316.**

MODELO	ALTURA EN METROS							DN	PESO	CAUDAL BOMBA SEGÚN MOTOR (l/hora)	
	HASTA 100 m		HASTA 150 m		HASTA 200 m		Ø"				Kg
	kW	Hp	kW	Hp	kW	Hp					
IFX-IFXP 5	0,25	0,35	0,37	0,50	0,55	0,75	1/2	4,5	360 330 294 258 228 192 156 120		
IFX-IFXP 10	0,37	0,50	0,55	0,75	0,75	1,00	3/4	4,9	810 750 684 618 552 486 420 360		
IFX-IFXP 15	0,55	0,75	0,75	1,00	1,10	1,50	3/4	5,0	1.230 1.152 1.074 996 918 840 768 690		
IFX-IFXP 25	0,75	1,00	1,50	2,00	2,20	3,00	3/4	6,0	1.740 1.650 1.560 1.470 1.380 1.296 1.200 1.110		
IFZ-IFZP 5	0,25	0,35	0,37	0,50	0,55	0,75	1/2	6,3	384 348 312 282 246 210 180 144		
IFZ-IFZP 10	0,37	0,50	0,55	0,75	0,75	1,00	3/4	6,7	816 750 684 618 552 492 420 360		
IFZ-IFZP 15	0,55	0,75	0,75	1,00	1,10	1,50	3/4	7,3	1.260 1.188 1.110 1.032 954 876 798 720		
IFZ-IFZP 25	0,75	1,00	1,50	2,00	2,20	3,00	3/4	8,3	1.800 1.698 1.602 1.506 1.404 1.308 1.206 1.110		

P.V.P.

Consulte precios con nuestro dpto. comercial

TABLA DE CONVERSIÓN DE VISCOSIDADES

CENTI-STOKES	GRADOS ENGLER	SEG. SAYBOLT	SEG. REDWOOD	CENTI-STOKES	GRADOS ENGLER	SEG. SAYBOLT	SEG. REDWOOD	CENTI-STOKES	GRADOS ENGLER	SEG. SAYBOLT	SEG. REDWOOD
1.500	197,4	6.818	6.073	540	71,1	2.455	2.186	140	18,4	637	567
1.450	190,8	6.591	5.870	530	69,7	2.409	2.146	130	17,1	592	527
1.400	184,2	6.364	5.668	520	68,4	2.364	2.105	120	15,8	547	486
1.350	177,6	6.136	5.466	510	67,1	2.318	2.065	110	14,5	501	446
1.300	171,1	5.909	5.263	500	65,8	2.273	2.024	100	13,2	456	405
1.250	164,5	5.682	5.061	490	64,5	2.228	1.984	95	12,5	433	385
1.200	157,9	5.455	4.858	480	63,2	2.182	1.943	90	11,9	411	365
1.150	151,3	5.227	4.656	470	61,8	2.137	1.903	85	11,2	388	345
1.100	144,7	5.000	4.453	460	60,5	2.091	1.862	80	10,5	365	325
1.050	138,2	4.773	4.251	450	59,2	2.046	1.822	75	9,9	343	304
1.000	131,6	4.546	4.049	440	57,9	2.000	1.781	70	9,2	320	284
950	125,0	4.318	3.846	430	56,6	1.955	1.741	65	8,6	298	264
900	118,4	4.091	3.644	420	55,3	1.909	1.701	60	7,9	275	244
850	111,8	3.864	3.441	410	53,9	1.864	1.660	55	7,3	252	224
800	105,3	3.637	3.239	400	52,6	1.819	1.620	50	6,6	230	203
790	103,9	3.591	3.198	390	51,3	1.773	1.579	45	6,0	207	183
780	102,6	3.546	3.158	380	50,0	1.728	1.539	40	5,3	185	163
770	101,3	3.500	3.117	370	48,7	1.682	1.498	35	4,7	163	143
760	100,0	3.455	3.077	360	47,4	1.637	1.458	30	4,1	141	123
750	98,7	3.409	3.037	350	46,1	1.591	1.417	25	3,5	118	103
740	97,4	3.364	2.996	340	44,7	1.546	1.377	20	2,9	97	85
730	96,1	3.318	2.956	330	43,4	1.500	1.336	15	2,3	77	67
720	94,7	3.273	2.915	320	42,1	1.455	1.296	10	1,8	58	51
710	93,4	3.227	2.875	310	40,8	1.410	1.255	5	1,4	42	37
700	92,1	3.182	2.834	300	39,4	1.364	1.215	1	1,0		
690	90,8	3.137	2.794	290	38,2	1.319	1.174				
680	89,5	3.091	2.753	280	36,8	1.273	1.134				
670	88,2	3.046	2.713	270	35,1	1.228	1.093				
660	86,8	3.000	2.672	260	34,2	1.182	1.053				
650	85,5	2.955	2.632	250	32,9	1.137	1.012				
640	84,2	2.909	2.591	240	31,6	1.091	972				
630	82,9	2.864	2.551	230	30,3	1.046	931				
620	81,6	2.818	2.510	220	28,9	1.001	891				
610	80,3	2.773	2.470	210	27,6	955	850				
600	78,9	2.727	2.429	200	26,3	910	810				
590	77,6	2.682	2.389	190	25,0	864	769				
580	76,3	2.637	2.348	180	23,7	819	729				
570	75,0	2.591	2.308	170	22,4	774	689				
560	73,7	2.546	2.267	160	21,0	728	648				
550	72,4	2.500	2.227	150	19,7	683	608				

Cst = Cps
Pe

Cst = Centistokes

Cps = Centipoises

Pe = Peso específico

Cada 20°E aumentar un 10%
la potencia instalada

ACCEDE A NUESTRA WEB Y DESCUBRE
EL SUMINISTRO DE BOMBEO MÁS COMPLETO



www.proindecsa.com





NEUMÁTICAS DOBLE DIAFRAGMA



BOMBAS DE DOBLE DIAFRAGMA



DESCRIPCIÓN

- Bombas accionadas por aire comprimido. **No precisan de electricidad.**
- Múltiples combinaciones de materiales para una completa compatibilidad con el fluido de bombeo.
- Autoaspirantes y autocebantes, **capaces de trabajar en seco.**
- Funcionamiento tanto en **superficie** como **sumergidas.**
- Prestaciones en función del caudal y la presión de aire.
- Bajo mantenimiento, no es necesaria la lubricación de la válvula de aire.
- Incluyen silenciador.
- Adecuadas para bombeo de fluidos con **alta viscosidad.**



NEUMÁTICAS DOBLE DIAFRAGMA



APTAS PARA UNA AMPLIA GAMA DE ENTORNOS INDUSTRIALES

- ✓ **Minera:** Transferencia de lodos y pulpas, manejo de fluidos abrasivos, suministro de lubricantes y grasas, y bombeo de productos químicos utilizados en procesos como la flotación y la lixiviación.
- ✓ **Química:** Ideales para transferir productos químicos corrosivos como ácidos y solventes, y para el drenaje en pozas de sumidero.
- ✓ **Alimentaria:** Demuestran su eficacia al refinar productos como chocolates, cremas u otros productos similares.
- ✓ **Textil:** Se usan en la estampación y el acabado textil, así como para suministrar colas y adhesivos en las máquinas laminadora.

INTERPRETACIÓN - CURVA DE UNA BOMBA NEUMÁTICA

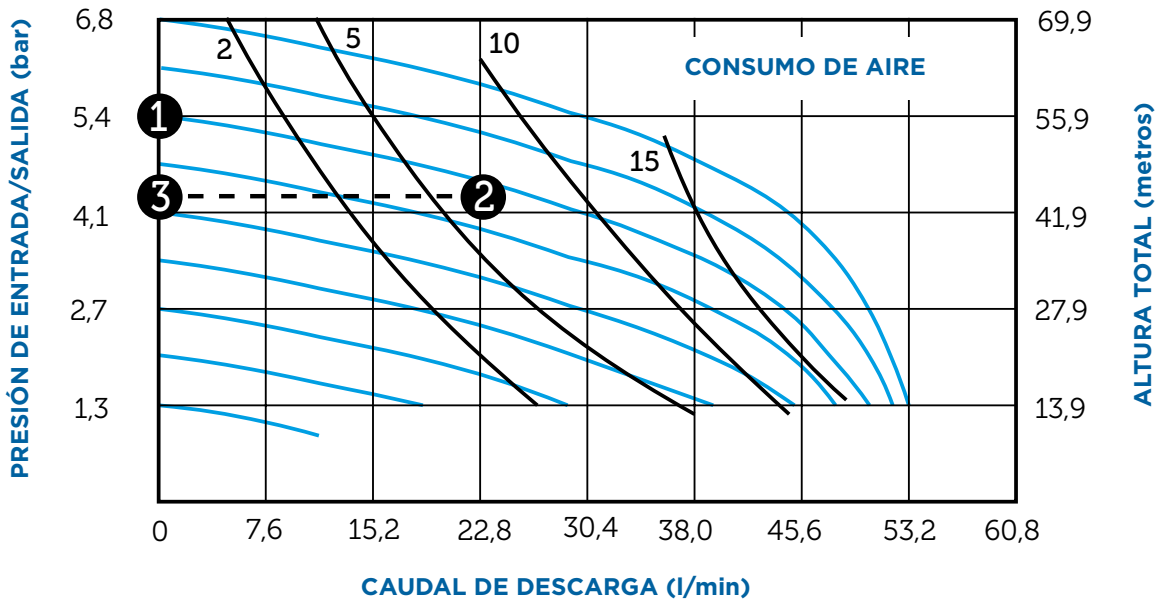

⚠ IMPORTANTE Para seleccionar una bomba neumática se deben conocer los siguientes datos:

① PRESIÓN DE DESCARGA

Veamos un ejemplo utilizando la curva de características que se muestra arriba (correspondiente a una bomba de 1/2"). Suponemos que se dispone de una presión de aire de 5,4 bar y que el caudal que se precisa es de 22,8 l/min.

Se sigue la curva cóncava azul ① partiendo de 5,4 bar hacia la derecha, donde se unirá a la línea vertical de los 22,8 l/min en ②.

Desde ese punto, debe trazar una línea recta hacia la izquierda y obtendrá la presión que tendrá en la impulsión (4,5 bar en este caso).

② PRESIÓN DE AIRE REQUERIDA

En este caso se procede con los pasos anteriores, al contrario. Teniendo una presión requerida de 4,5 bar ③, trazamos una línea recta al caudal requerido ② de 22,8 l/min. Por último, desde aquí seguimos la curva azul hacia la izquierda hasta llegar al punto ①, donde encontraremos la presión requerida de 5,4 bar.

Si precisa una mayor presión en la impulsión y no la puede obtener con la bomba seleccionada, debe seleccionar una bomba de mayor tamaño.

③ CONSUMO DE AIRE

Las líneas rojas convexas representan el consumo de aire, y la línea más cercana al lugar donde intersectan la línea azul y la del caudal ② representa la capacidad de aire requerida. En nuestro ejemplo, el consumo de aire sería de aproximadamente 6 SCFM. Se multiplica por 1,7 para obtener la medida en m³/h, lo que nos daría un consumo de aire en el ejemplo de 10,2 m³/h.

BOMBAS DE DOBLE DIAFRAGMA

1/4" - 3/8"



ÁREA DE TRABAJO

- Caudal máx.: **27 l/min**
- Altura máx.: **70 m**
- Presión máx.: **7 bar**
- Paso de sólidos: **1,6 mm**

MODELO	Conex. líquido	Conex. aire	T. Máx.	CUERPO	DIAFRAGMA	VÁLVULA BOLA	ASIENTO VÁLVULA	P.V.P.
	Ø"	Ø"	°C					
KT-025-TK	1/4 - 3/8*	1/4	93	PVdF	Teflón	Teflón	PVdF	1.118,00
PS-025-TP	1/4 - 3/8*	1/4	66	PP	Santoprene	Teflón	PP	474,00
PT-025-TP	1/4 - 3/8*	1/4	66	PP	Teflón	Teflón	PP	427,00

*Este modelo incluye doble salida/entrada. Aspiración/impulsión en el lateral de 1/4" y aspiración/impulsión superior e inferior de 3/8".

BOMBAS DE DOBLE DIAFRAGMA

1/2" - 3/4"



ÁREA DE TRABAJO

- Caudal máx.: **57 l/min**
- Altura máx.: **84 m**
- Presión máx.: **8,4 bar**
- Paso de sólidos: **2,5 mm**

MODELO	Conex. líquido	Conex. aire	T. Máx.	CUERPO	DIAFRAGMA	VÁLVULA BOLA	ASIENTO VÁLVULA	P.V.P.
	Ø"	Ø"	°C					
AS-05-SI	1/2 - 3/4*	3/8	100	Aluminio	Santoprene	Santoprene	INOX 304	608,00
AT-05-TI	1/2 - 3/4*	3/8	100	Aluminio	Teflón	Teflón	INOX 304	706,00
KT-05-TK	1/2 - 3/4*	3/8	93	PVdF	Teflón	Teflón	PVdF	2.065,00
LS-05-SL	1/2 - 3/4*	3/8	100	INOX 316	Santoprene	Santoprene	INOX 316	1.227,00
LT-05-TL	1/2 - 3/4*	3/8	100	INOX 316	Teflón	Teflón	INOX 316	1.346,00
PS-05-SP	1/2 - 3/4*	3/8	66	PP	Santoprene	Santoprene	PP	641,00
PT-05-TP	1/2 - 3/4*	3/8	66	PP	Teflón	Teflón	PP	706,00

*Este modelo incluye doble salida/entrada. Aspiración/impulsión en el lateral de 1/2" y aspiración/impulsión superior e inferior de 3/4".

BOMBAS DE DOBLE DIAFRAGMA

1"



ÁREA DE TRABAJO

- Caudal máx.: **157 l/min**
- Altura máx.: **84 m**
- Presión máx.: **8,4 bar**
- Paso de sólidos: **2,5 mm**

MODELO	Conex. líquido	Conex. aire	T. Máx.	CUERPO	DIAFRAGMA	VÁLVULA BOLA	ASIENTO VÁLVULA	P.V.P.
	Ø"	Ø"	°C					
AS-10-SS	1	1/2	100	Aluminio	Santoprene	Santoprene	Santoprene	908,00
AT-10-TT	1	1/2	100	Aluminio	Teflón	Teflón	Teflón	1.171,00
KT-10-TK	1	1/2	93	PVdF	Teflón	Teflón	PVdF	3.897,00
LS-10-SS	1	1/2	100	INOX 316	Santoprene	Santoprene	Santoprene	2.129,00
LT-10-TT	1	1/2	100	INOX 316	Teflón	Teflón	Teflón	2.548,00
PS-10-SP	1	1/2	66	PP	Santoprene	Santoprene	PP	1.041,00
PT-10-TP	1	1/2	66	PP	Teflón	Teflón	PP	1.354,00

BOMBAS DE DOBLE DIAFRAGMA

1 - 1/2"



ÁREA DE TRABAJO

- Caudal máx.: **358 l/min**
- Altura máx.: **84 m**
- Presión máx.: **8,4 bar**
- Paso de sólidos: **4 mm**

MODELO	Conex. líquido	Conex. aire	T. Máx.
	Ø"	Ø"	°C
AS-15-SS	1 - 1/2	1/2	100
AT-15-TT	1 - 1/2	1/2	100
KT-15-TK	1 - 1/2	1/2	93
LS-15-SS	1 - 1/2	1/2	100
LT-15-TT	1 - 1/2	1/2	100
PS-15-SP	1 - 1/2	1/2	66
PT-15-TP	1 - 1/2	1/2	66

CUERPO	DIAFRAGMA	VÁLVULA BOLA	ASIENTO VÁLVULA
--------	-----------	--------------	-----------------

MATERIALES DE CONSTRUCCIÓN				P.V.P.
Aluminio	Santoprene	Santoprene	Santoprene	1.366,00
Aluminio	Teflón	Teflón	Teflón	1.887,00
PVdF	Teflón	Teflón	PVdF	6.246,00
INOX 316	Santoprene	Santoprene	Santoprene	3.378,00
INOX 316	Teflón	Teflón	Teflón	4.080,00
PP	Santoprene	Santoprene	PP	1.419,00
PP	Teflón	Teflón	PP	1.939,00

*Este modelo incluye doble salida/entrada. Aspiración/impulsión en el lateral de 1" y aspiración/impulsión superior e inferior de 1/2".

BOMBAS DE DOBLE DIAFRAGMA

2"



ÁREA DE TRABAJO

- Caudal máx.: **587 l/min**
- Altura máx.: **84 m**
- Presión máx.: **8,4 bar**
- Paso de sólidos: **6 mm**

MODELO	Conex. líquido	Conex. aire	T. Máx.
	Ø"	Ø"	°C
AS-20-SS	2	1/2	100
AT-20-TT	2	1/2	100
PS-20-SP	2	1/2	66
PT-20-TP	2	1/2	66

CUERPO	DIAFRAGMA	VÁLVULA BOLA	ASIENTO VÁLVULA
--------	-----------	--------------	-----------------

MATERIALES DE CONSTRUCCIÓN				P.V.P.
Aluminio	Santoprene	Santoprene	Santoprene	2.004,00
Aluminio	Teflón	Teflón	Teflón	2.590,00
PP	Santoprene	Santoprene	PP	2.310,00
PP	Teflón	Teflón	PP	2.896,00

BOMBAS DE DOBLE DIAFRAGMA

3"



ÁREA DE TRABAJO

- Caudal máx.: **1060 l/min**
- Altura máx.: **84 m**
- Presión máx.: **8,4 bar**
- Paso de sólidos: **9,4 mm**

MODELO	Conex. líquido	Conex. aire	T. Máx.
	Ø"	Ø"	°C
AS-30-SS	3	3/4	100
AT-30-TT	3	3/4	100
PT-30-TP	3	3/4	66

CUERPO	DIAFRAGMA	VÁLVULA BOLA	ASIENTO VÁLVULA
--------	-----------	--------------	-----------------

MATERIALES DE CONSTRUCCIÓN				P.V.P.
Aluminio	Santoprene	Santoprene	Santoprene	3.226,00
Aluminio	Teflón	Teflón	Teflón	4.301,00
PP	Teflón	Teflón	Teflón	6.359,00

APLICACIONES DE ALTA VISCOSIDAD

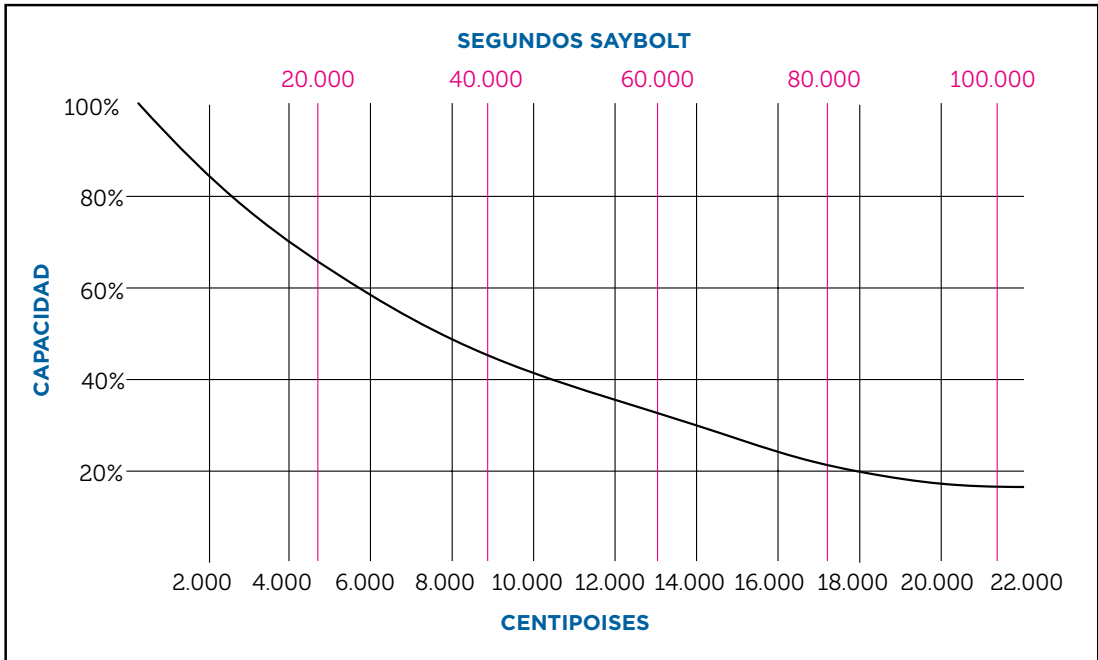

Como se puede observar en la gráfica, según aumentan las viscosidades se reduce la capacidad de la bomba. No deben excederse los 22.000 centipoises ó 100.000 segundos Saybolt en las bombas desde 1/2" a 3". No exceder los 10.000 centipoises ó 50.000 segundos Saybolt en las de 1/4".

Algunos puntos a recordar cuando se bombean altas viscosidades:



1. Instale la bomba lo más próxima posible al nivel del depósito o por debajo de este, para garantizar un óptimo flujo del líquido a bombear.
2. Aumente el diámetro de los tubos de aspiración, pudiendo ser hasta tres veces el diámetro de entrada de la bomba. En caso de disponer de orificios dobles, estos pueden emplearse para optimizar la operación.
3. Inicie el arranque de la bomba de manera gradual, utilizando una válvula de control en la entrada del aire para regular el flujo de forma precisa.
4. Determine la presión de aire óptima, siendo esta aquella en la que un incremento adicional no genera un aumento en el caudal de la bomba.
5. Para necesidades de mayor caudal, seleccione una bomba de mayor capacidad que cumpla con los requisitos operativos.



SCHMITT
FAGGIOLATI
SACEMI
MEC-2



PYD
ELECTROBOMBAS



DESCRIPCIÓN

- Todas las series son **resistentes a las sustancias químicas** y son particularmente adecuadas para la elevación de medios de alta pureza y medios agresivos.
- Flujos volumétricos de hasta 500 l/min (30m³/h)
- Alturas de elevación de hasta 40 metros.
- Temperatura máxima admisible: 150°C (para modelos en materiales metálicos)
- Potencia del motor hasta 5,5 kW.
- Diversos modelos están **aprobados para el uso en zonas con peligro de explosión** 



APTAS PARA TODAS
LAS INDUSTRIAS

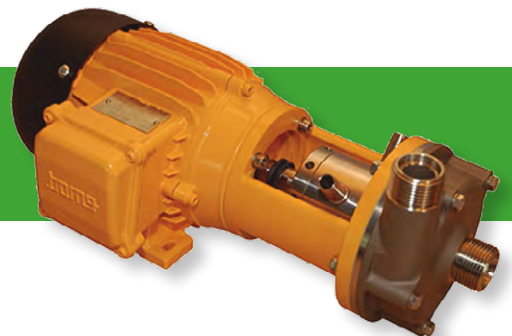

Debido a su construcción y a los materiales altamente resistentes y adaptables a las respectivas condiciones de funcionamiento –PVdF, PP y acero inoxidable– resultan adecuadas para elevar y hacer circular medios de alta pureza, agresivos, abrasivos, orgánicos, calientes, contaminados y metálicamente contaminados, cristalizables, estériles, corrosivos, radiactivos, tóxicos, nocivos para el medio ambiente, sensibles, valiosos, ácidos, alcalinos, cargados con sólidos y gasificados, así como medios de medianamente viscosos hasta muy viscosos.

Debido a esto, se utilizan tanto en plantas industriales como en institutos de investigación y laboratorios de muy diversas áreas.

- Todos los modelos se equipan de manera estándar con motores de corriente trifásica, con un alcance de potencia de entre 0,12 y 5,5 KW.
- También se pueden suministrar motores de corriente alterna, con blindaje contra explosión y con encapsulamiento resistente a presión.



BOMBAS DE ARRASTRE MAGNÉTICO SERIE MPN - PVDF/PP

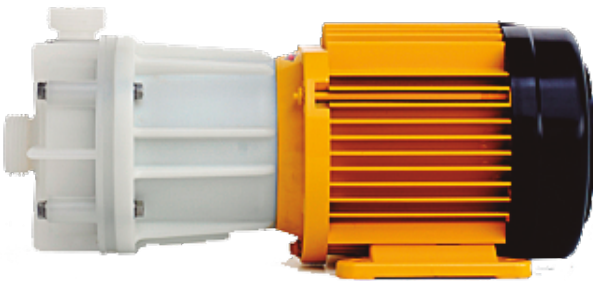

MODELO	P ₂		P.V.P.
	kW	Hp	
MPN 80	0,18	0,25	Consulte precios con nuestro dpto. comercial
MPN 101	0,18	0,25	
MPN 115	0,25	0,34	
MPN 130	0,55	0,75	
MPN 150	1,10	1,50	
MPN 170	2,20	3,00	
MPN 190	3,00	4,00	

DESCRIPCIÓN

- Bombas centrífugas con acoplamiento magnético, **herméticamente estancas**, equipadas con **cojinetes hidrodinámicos** de mínimo mantenimiento en PTFE/cerámica o en SiC/SiC y con imanes de altísima calidad.

MATERIALES

- Cuerpo: **PVdF/PP**

ÁREA DE TRABAJO

- Aplicaciones de alta pureza.
- Temperatura máxima en PP: **80°C**
- Temperatura máxima en PVdF: **95°C**

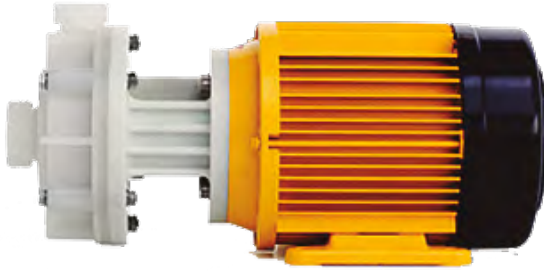

MODELO	P ₂		P.V.P. ^F
	kW	Hp	
U 80	0,18	0,25	Consulte precios con nuestro dpto. comercial
U 100	0,18	0,25	
U 115	0,25	0,34	
U 130	0,55	0,75	
U 150	1,10	1,50	
U 170	2,20	3,00	
U 190	3,00	4,00	
U 210	5,50	7,50	

DESCRIPCIÓN

- Bombas centrífugas con cierre de **anillo deslizante** de acción simple en distintos materiales.
- Suministrables con cierres mecánicos dobles, denominación UP-DO.

MATERIALES

- Especificaciones A/B/C: **Inserción impulsor, contra-eje, extensión eje en acero inoxidable. Cierres mecánicos carbón/cerámica/vitón/INOX.**
- Especificaciones A/HC, B/HC y C/HC (bajo demanda): **Las mismas piezas en Hastelloy C. Cierres mecánicos SiC, FEP o teflón, sencillos y dobles.**

ÁREA DE TRABAJO

- Para medios de alta viscosidad o cargados con sólidos.
- Temperatura máxima: **95°C**

BOMBAS CENTRÍFUGAS SERIE UP - ACERO INOXIDABLE 14581

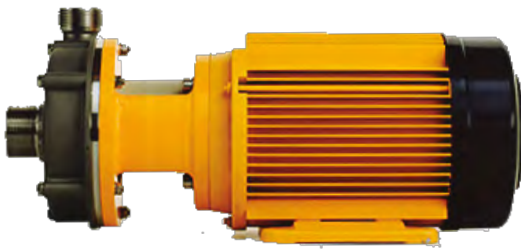

MODELO	P ₂		P.V.P. ^F
	kW	Hp	
UP 80	0,18	0,25	Consulte precios con nuestro dpto. comercial
UP 100	0,18	0,25	
UP 115	0,25	0,34	
UP 130	0,55	0,75	
UP 150	1,10	1,50	
UP 170	2,20	3,00	
UP 190	3,00	4,00	
UP 210	5,50	7,50	

DESCRIPCIÓN

- Bombas centrífugas equipadas con cierres mecánicos simples en distintos materiales.
- Suministrables con cierres mecánicos dobles, denominación UP-DO.

MATERIALES

- Especificaciones A/B/C: **Inserción impulsor, contra-eje, extensión eje en acero inoxidable. Cierres mecánicos carbón/cerámica/vitón/INOX.**
- Especificaciones A/HC, B/HC y C/HC (bajo demanda): **Las mismas piezas en Hastelloy C. Cierres mecánicos SiC, FEP o teflón, sencillos y dobles.**

ÁREA DE TRABAJO

- Para medios de alta viscosidad o cargados con sólidos y alta temperatura del medio.
- Temperatura máxima: **150°C**

BOMBAS AUTOASPIRANTES SERIE S - PVC/PP

DESCRIPCIÓN

- Bombas centrífugas autocebantes.

MATERIALES

- Carcasa en PVC/PP, resto en PVdF.
- Especificaciones A/B/C: Impulsor, contra-eje, extensión eje en acero inoxidable. Cierres mecánicos carbón/cerámica/vitón/INOX.
- Especificaciones A/HC, B/HC y C/HC (bajo demanda): Las mismas piezas en Hastelloy C. Cierres mecánicos SiC, FEP o teflón, sellos y dobles.

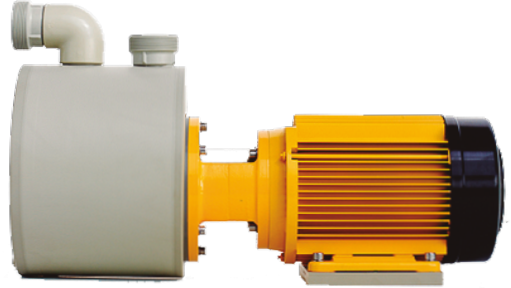

ÁREA DE TRABAJO

- Temperatura del líquido: De 10° a 50°C
- Altura de aspiración: Hasta 5 metros.

MODELO	P ₂		ALTURA MÁX metros	CAUDAL MÁX l/min	P.V.P. Consulte precios con nuestro dpto. comercial
	kW	Hp			
S 115	0,25	0,35	11	63	F
S 130	0,55	0,75	14	118	
S 150	1,10	1,50	19	166	
S 170	2,20	3,00	28	210	

BOMBAS PERIFÉRICAS SERIE P - PVDF

DESCRIPCIÓN

- Electrobomba periférica autoaspirante, con acoplamiento magnético.
- Libre de fugas, anticorrosiva y de fácil mantenimiento.
- Relación lineal entre el caudal y la altura, presión alta a caudal bajo.

MATERIALES

- Partes en contacto con el fluido: PVdF
- Elastómero: Vitón, EPDM, FEP.

ÁREA DE TRABAJO

- Capaz de trabajar en medios ácidos, lejías, disolventes, etc.
- Especialmente diseñada para caudales pequeños y elevadas presiones.

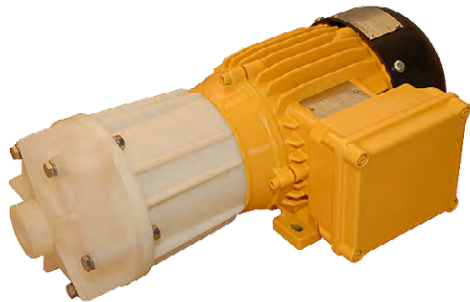

MODELO	P ₂		ALTURA MÁX metros	CAUDAL MÁX l/min	P.V.P. Consulte precios con nuestro dpto. comercial
	kW	Hp			
P 130	1,10	1,50	35	45	F

BOMBAS VERTICALES SERIE T- PVDF/PP

DESCRIPCIÓN

- Bombas sumergibles verticales construidas bajo el principio de eje de libre rotación, por lo que no montan ni cojinetes ni cierres, pudiendo trabajar en seco.

MATERIALES

- Cuerpo: **PVdF, PP**

ÁREA DE TRABAJO

- En recipientes o baños de inmersión que no se pueden embridar lateralmente.
- Temperaturas máx.: **80°C para PP; 95°C para PVdF.**



MODELO	P ₂		MATERIAL CONST.	ALTURA MÁX	CAUDAL MÁX	P.V.P.
	kW	Hp		metros	l/min	
T 100	0,12	0,17	PP PVdF	6	55	Consulte precios con nuestro dpto. comercial
T 115	0,25	0,35	PP PVdF	10	85	
T 130	0,55	0,75	PP PVdF	12,5	128	
T 150	0,75	1,00	PP PVdF	17,5	163	
T 170	1,50	2,00	PP PVdF	22	230	
T 190	2,20	3,00	PP PVdF	28	281	

ET: Largo de caña en mm

BOMBAS VERTICALES SERIE TE - ACERO INOXIDABLE

DESCRIPCIÓN

- Bombas sumergibles verticales construidas bajo el principio de eje de libre rotación, por lo que no montan ni cojinetes ni cierres, pudiendo trabajar en seco.

MATERIALES

- Cuerpo: **Acero inoxidable 1.4571**

ÁREA DE TRABAJO

- En recipientes o baños de inmersión que no se pueden embridar lateralmente y con alta temperatura del medio.
- Temperatura máx.: **150°C**



MODELO	P ₂		MATERIAL CONST.	ALTURA MÁX	CAUDAL MÁX	P.V.P.
	kW	Hp		metros	l/min	
TE 115	0,25	0,35	PP PVdF	8	98	Consulte precios con nuestro dpto. comercial
TE 130	0,55	0,75	PP PVdF	11	139	
TE 150	0,75	1,00	PP PVdF	15	170	
TE 170	1,50	2,00	PP PVdF	20	274	
TE 190	2,20	3,00	PP PVdF	23	285	

ET: Largo de caña en mm



DESCRIPCIÓN

- Las electrobombas de **SACEMI** están diseñados para la circulación de líquidos (no aptas para líquidos inflamables) y mezclas de refrigeración, como la taladrina, un fluido refrigerante y lubricante usado en máquinas herramientas. Sus modelos incluyen bombas de caña, utilizadas en depósitos y sistemas de refrigeración.
- Son esenciales en **máquinas herramientas**, donde garantizan el enfriamiento y la lubricación de herramientas de corte, eliminan virutas y residuos, y recirculan fluidos de proceso.
- Gracias a su **resistencia a fluidos abrasivos** y su capacidad para manejar mezclas de aceite y agua, destacan por su durabilidad, eficiencia energética y versatilidad, mejorando la eficiencia y prolongando la vida útil de los equipos industriales.



RECONOCIDAS POR SU
DURABILIDAD Y EFICIENCIA



MÁQUINAS HERRAMIENTAS INMERSIÓN

SERIE IMM / SQ



SERIE IMM

DESCRIPCIÓN SERIE IMM

- Electrobombas para la transferencia de líquidos limpios o con impurezas hasta 2-3 mm.
- Útiles para el trasiego de agua, emulsiones y sustancias aceitosas.

MATERIALES

- Ver tabla

ÁREA DE TRABAJO

- Temperatura máx. del líquido: 90°C

Viscosidad máx.: 3°Engler



MODELO	P ₂		INT. A	ALTURA DE CARGA EN METROS													
	kW	Hp		0	1	2	3	4	5	8	9	10	12	14	16	18	
SQ 56/S	0,16	0,21	0,55	CAUDAL (l/min)													
SQ 63/S	0,30	0,40	0,58	73	62	48	30										
SQ 71/A	0,53	0,71	1,40	100	90	75	55	30									
SQ 71/B	0,78	1,05	1,90	195	190	180	168	156	141	95	78	55	28				
SQ 80/A	1,15	1,54	1,90	230	220	210	200	190	180	138	122	107	66				
SQ 80/B	1,47	1,97	2,80	330	320	310	300	290	280	245	232	220	188	145	90		
IMM 40/A	0,10	0,13	0,29	400	390	380	370	360	347	310	300	290	245	190	138	60	
IMM 50/A	0,12	0,16	0,29	16	14	9	3										
IMM 63/A	0,30	0,40	0,58	24	22	18	10										
IMM 63/B	0,40	0,50	0,90	100	95	86	78	53	32								
IMM 71/A	0,53	0,70	1,60	115	110	103	96	82	64								
IMM 71/B	0,78	1,05	1,90	198	187	176	167	157	144	106	90	70	37				
IMM 80/A	1,15	1,50	1,90	230	220	210	200	190	180	138	122	109	77	39			
IMM 80/B	1,47	1,97	2,80	330	320	310	300	290	280	245	232	220	188	145	90		
IMM 90/A	1,85	2,50	5,00	400	390	380	370	360	347	310	300	290	245	190	138	60	
IMM 90/B	2,80	3,80	6,20	740	730	710	690	670	650	530	470	410	230				
IMM 100/B	4,43	5,90	8,60	980	970	950	920	890	860	770	730	680	570				
				1.200	1.170	1.140	1.105	1.075	1.040	940	900	850	750	650	550	450	

Todos los modelos son trifásicos 230/400V. Consulte suplemento para opción monofásica.

MÁQUINAS HERRAMIENTAS INMERSIÓN

SERIES IMM / SQ



SERIE SQ

DESCRIPCIÓN SERIE SQ

- Electrobombas para la transferencia de líquidos limpios o con impurezas hasta 2-3 mm.
- Útiles para el trasiego de agua, emulsiones y sustancias aceitosas.

MATERIALES

- Ver tabla

ÁREA DE TRABAJO

- Temperatura máx. del líquido: **70°C**
- Viscosidad máx.: **3°Engler**

LARGO DESDE LA PLACA BASE	MATERIALES DE CONSTRUCCIÓN			P.V.P.
	TAPA ASP.	CAÑA	IMPULSOR	
mm				
-	-	Fundición	Nylon	227,50
-	-	Fundición	Nylon	343,30
-	-	Fundición	Bronce	467,00
-	-	Fundición	Bronce	498,80
-	-	Fundición	Bronce	632,60
-	-	Fundición	Bronce	658,90
80-120-150-180	Plástico	Plástico	Nylon	96,80
80-120-150-180	Plástico	Plástico	Nylon	125,60
150-200-250-300	Plástico	Aluminio	Nylon	325,30
150-200-250-300	Plástico	Aluminio	Nylon	356,90
200-250-325	Aluminio	Aluminio	Bronce	490,70
440	Aluminio	Aluminio	Bronce	547,10
200-250-325	Aluminio	Aluminio	Bronce	534,60
440	Aluminio	Aluminio	Bronce	587,00
200-250-300-350	Aluminio	Aluminio	Bronce	775,80
530	Aluminio	Aluminio	Bronce	997,80
200-250-300-350	Aluminio	Aluminio	Bronce	811,60
530	Aluminio	Aluminio	Bronce	1.036,30
350	Fundición	Fundición	Fundición	1.320,20
600	Fundición	Acero	Fundición	1.431,80
800	Fundición	Acero	Fundición	1.476,00
350	Fundición	Fundición	Fundición	1.525,50
600	Fundición	Acero	Fundición	1.616,30
800	Fundición	Acero	Fundición	1.683,80
350	Fundición	Fundición	Fundición	1.755,70
600	Fundición	Acero	Fundición	1.849,50
800	Fundición	Acero	Fundición	1.910,00

Todos los modelos son trifásicos 230/400V. Consulte suplemento para opción monofásica.

MÁQUINAS HERRAMIENTAS INMERSIÓN

SERIE SP / SPV



SERIE SP

DESCRIPCIÓN SERIE SP

- Electrobombas para la transferencia de líquidos limpios o con impurezas hasta 2-3 mm.
- Útiles para el trasiego de agua, emulsiones y sustancias aceitosas.

MATERIALES

- Ver tabla

ÁREA DE TRABAJO

- Temperatura máx. del líquido: **70°C**
- Viscosidad máx.: **3°Engler**



MODELO	P ₂		INT.	ALTURA DE CARGA EN METROS													
	kW	Hp	A	0	1	2	3	4	5	6	7	9	11	12	13	14	
	CAUDAL (l/min)																
SP 12	0,15	0,20	0,32	60	52	43	30	8									
SP 18	0,16	0,21	0,55	70	63	55	42	25	5								
SP 25	0,30	0,40	0,58	85	81	75	64	50	30	3							
SP 33	0,40	0,50	0,90	100	95	87	77	65	50	30	5						
SP 50	0,53	0,70	1,40	180	175	170	165	160	150	140	125	81	25				
SP 75	0,78	1,05	1,90	220	215	208	200	195	180	168	150	120	65	30	5		
SP 100	1,15	1,50	1,90	300	290	285	273	260	277	225	200	150	85	55	15	5	
SP 150	1,47	1,97	2,80	360	350	340	310	300	280	260	240	180	125	90	25	5	
SPV 12	0,15	0,20	0,32	60	52	43	30	8									
SPV 18	0,16	0,21	0,55	70	63	55	42	25	5								
SPV 25	0,30	0,40	0,58	85	81	75	64	50	30	3							
SPV 33	0,40	0,50	0,90	100	95	87	77	65	50	30	5						

Todos los modelos son trifásicos 230/400V. Consulte suplemento para opción monofásica.

MÁQUINAS HERRAMIENTAS INMERSIÓN

SERIES SP / SPV



SERIE SPV

DESCRIPCIÓN SERIE SPV

- Electrobombas para la transferencia de líquidos limpios o con impurezas hasta 2-3 mm.
- Útiles para el trasiego de agua, emulsiones y sustancias aceitosas.

MATERIALES

- Ver tabla

ÁREA DE TRABAJO

- Temperatura máx. del líquido: **70°C**
- Viscosidad máx.: **3°Engler**

LARGO DESDE LA PLACA BASE	MATERIALES DE CONSTRUCCIÓN			P.V.P.
	TAPA ASP.	CAÑA	IMPULSOR	
mm				
90-120-170-220	Valox	Fundición	Valox	268,80
270-350	Valox	Fundición	Valox	293,70
90-120-170-220	Valox	Fundición	Valox	285,20
270-350	Valox	Fundición	Valox	308,80
90-120-170-220	Valox	Fundición	Valox	398,30
270-350	Valox	Fundición	Valox	417,50
90-120-170-220	Valox	Fundición	Valox	427,30
270-350	Valox	Fundición	Valox	452,20
200-270-350	Valox	Fundición	Valox	559,60
440-550	Valox	Fundición	Valox	587,00
200-270-350	Valox	Fundición	Valox	602,30
440-550	Valox	Fundición	Valox	628,40
200-270-350	Valox	Fundición	Valox	847,50
440-550	Valox	Fundición	Valox	875,30
200-270-350	Valox	Fundición	Valox	886,20
440-550	Valox	Fundición	Valox	916,50
90-120-170-220	Plástico	Plástico	Valox	184,80
270-350	Plástico	Plástico	Valox	197,30
90-120-170-220	Plástico	Plástico	Valox	192,80
270-350	Plástico	Plástico	Valox	205,50
90-120-170-220	Plástico	Plástico	Valox	290,80
270-350	Plástico	Plástico	Valox	303,50
90-120-170-220	Plástico	Plástico	Valox	320,20
270-350	Plástico	Plástico	Valox	331,60

Todos los modelos son trifásicos 230/400V. Consulte suplemento para opción monofásica.



MÁQUINAS HERRAMIENTAS INMERSIÓN

SERIES EPC / MP



SERIE EPC

DESCRIPCIÓN SERIE EPC

- Electrobombas para transferencia de líquidos limpios.
- Los componentes hidráulicos permiten su uso con emulsiones y sustancias aceitosas, glicoles y líquidos en general, debido a sus materiales de construcción, resistentes a la oxidación.

MATERIALES

- Ver tabla

ÁREA DE TRABAJO

- Temperatura máx. del líquido: **90°C**
- Viscosidad máx.: **3°Engler**



MODELO	P ₂			INT.	ALTURA DE CARGA EN METROS												
	kW	Hp	A		0	5	10	20	30	40	50	60	70	80	90	95	100
					CAUDAL (l/min)												
EPC 63C	0,54	0,70	1,10	40	35	29	18	6									
EPC 71B	1,10	1,50	1,90	55	50	43	32	19	7								
EPC 80B	1,70	2,30	2,90	70	65	59	49	38	27	17	6						

MODELO	P ₂			INT.	ALTURA DE CARGA EN METROS														
	kW	Hp	A		0	4	8	12	16	20	25	28	32	35	40	45	50	55	60
					CAUDAL (l/min)														
MP 63C	0,54	0,70	1,55	112	92	70	45	27	0										
MP 71A	0,70	0,90	1,72	95	83	67	47	33	0										
MP 71B	0,95	1,30	2,38	102	92	80	68	58	40	18	0								
MP 80C	2,20	3,00	3,50	238	227	211	195	178	146	123	80	30	0						
MP 90B	3,60	4,80	5,40	245	236	224	217	211	197	180	160	140	130	104	50	10	0		
MP 100B	5,90	7,90	10,00	338	330	314	305	290	275	255	240	220	205	178	145	110	75	48	

Todos los modelos son trifásicos 230/400V. Consulte suplemento para opción monofásica.

MÁQUINAS HERRAMIENTAS INMERSIÓN

SERIES EPC / MP



SERIE MP

DESCRIPCIÓN SERIE MP

- Electrobombas para transferencia de líquidos conteniendo impurezas hasta 2-3 mm.
- Los componentes hidráulicos permiten su uso con emulsiones y sustancias aceitosas, glicoles y líquidos en general, debido a sus materiales de construcción, resistentes a la oxidación.

MATERIALES

- Ver tabla

ÁREA DE TRABAJO

- Temperatura máx. del líquido: **90°C**
- Viscosidad máx.: **3°Engler**

LARGO DESDE LA PLACA BASE	MATERIALES DE CONSTRUCCIÓN			P.V.P.
	TAPA ASP.	CAÑA	IMPULSOR	
mm				
100-130	Fundición	Acero	Fundición	562,80
180-230	Fundición	Acero	Fundición	587,60
280-360	Fundición	Acero	Fundición	615,00
100-130	Fundición	Acero	Fundición	704,30
180-230	Fundición	Acero	Fundición	743,80
280-360	Fundición	Acero	Fundición	781,00
100-130	Fundición	Acero	Fundición	843,00
180-230	Fundición	Acero	Fundición	882,70
280-360	Fundición	Acero	Fundición	922,30

LARGO DESDE LA PLACA BASE	MATERIALES DE CONSTRUCCIÓN			P.V.P.
	TAPA ASP.	CAÑA	IMPULSOR	
mm				
180-230-280-330	Aluminio	Aluminio	Bronce	398,30
180-230-280-330	Aluminio	Aluminio	Bronce	650,60
210-260-310-360	Aluminio	Aluminio	Bronce	700,00
230-280	Aluminio	Aluminio	Bronce	937,20
355-470	Aluminio	Aluminio	Bronce	964,60
265-315	Aluminio	Aluminio	Bronce	1075,00
390-505	Aluminio	Aluminio	Bronce	1130,00
265-315	Aluminio	Aluminio	Bronce	1405,70
365-415	Aluminio	Aluminio	Bronce	1447,10
595	Aluminio	Aluminio	Bronce	1670,20

Todos los modelos son trifásicos 230/400V. Consulte suplemento para opción monofásica.



MÁQUINAS HERRAMIENTAS ALTA PRESIÓN

SERIE AP



DESCRIPCIÓN

- Electrobombas para trasiego de líquidos con impurezas de hasta 2 mm.
- Para ser instalada a unos 6-7 mm de la base del depósito.

MATERIALES

- Ver tabla

ÁREA DE TRABAJO

- Temperatura máx. del líquido: **90°C**
- Viscosidad máx.: **3°Engler**



MODELO	P ₂		INT.	ALTURA DE CARGA EN METROS													
	kW	Hp	A	10	12	14	16	18	20	22	24	26	28	30	34	36	
AP 80B	2,19	2,90	3,2	270	260	250	225	200	175	150	115	75					
AP 90A	2,08	2,80	5,4	300	290	277	265	252	240	225	205	180	150	110			
AP 90B	3,60	4,80	6,2	450	435	420	400	385	360	320	280	240	200	160			
AP 100A	4,43	5,90	8,4	560	550	540	520	500	480	460	440	405	370	330	240		
AP 112B	6,00	8,00	12,2	715	700	680	660	640	610	580	550	515	475	435	340	280	

Todos los modelos son trifásicos 230/400V. Consulte suplemento para opción monofásica.

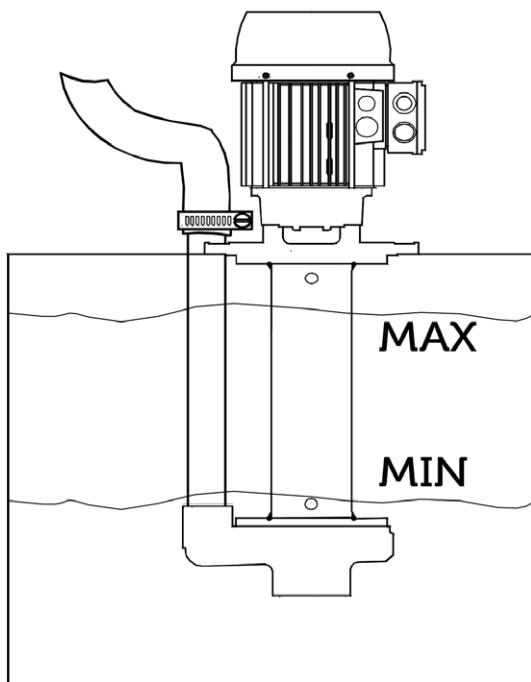
MÁQUINAS HERRAMIENTAS ALTA PRESIÓN
SERIE AP

F

LARGO DESDE LA PLACA BASE	MATERIALES DE CONSTRUCCIÓN			P.V.P.
	TAPA ASP.	CAÑA	IMPULSOR	
mm				
320	Fundición	Fundición	Fundición	1.394,60
450-610	Fundición	Acero	Fundición	1.554,20
860	Fundición	Acero	Fundición	1.650,70
320	Fundición	Fundición	Fundición	1.451,10
450-610	Fundición	Acero	Fundición	1.608,10
860	Fundición	Acero	Fundición	1.707,40
320	Fundición	Fundición	Fundición	1.659,30
450-610	Fundición	Acero	Fundición	1.819,20
860	Fundición	Acero	Fundición	1.916,90
320	Fundición	Fundición	Fundición	1.870,00
450-610	Fundición	Acero	Fundición	2.029,80
860	Fundición	Acero	Fundición	2.124,70
320	Fundición	Fundición	Fundición	2.337,10
450-610	Fundición	Acero	Fundición	2.493,00
860	Fundición	Acero	Fundición	2.608,70

Todos los modelos son trifásicos 230/400V. Consulte suplemento para opción monofásica.

MÁQUINAS HERRAMIENTAS ALTA PRESIÓN

SERIE AU



DESCRIPCIÓN

- Electrobombas para la transferencia de líquidos limpios.
- Útil para el trasiego de agua, emulsiones y sustancias aceitosas.

MATERIALES

- Ver tabla

ÁREA DE TRABAJO

- Viscosidad máx.: **3°Engler**

MODELO	P ₂			INT	ALTURA DE CARGA EN METROS							P.V.P.
	kW	Hp	A		0	2	4	6	8	10	12	
					CAUDAL (l/min)							
AU 56	0,16	0,20	0,55	11	9	8	6	4	2	0	285,20	
AU 63	0,30	0,40	0,52	14	12	10	8	6	4	0	418,80	

MÁQUINAS HERRAMIENTAS TRASVASE

SERIE TR



DESCRIPCIÓN

- Electrobombas para transferencia de líquidos limpios y con impurezas de hasta 2-3 mm.
- Los componentes hidráulicos permiten su uso con emulsiones y sustancias aceitosas, glicoles y líquidos en general, debido a sus materiales de construcción, resistentes a la oxidación.

MATERIALES

- Ver tabla

ÁREA DE TRABAJO

- Temperatura máx. del líquido: **90°C**
- Viscosidad máx.: **3°Engler**

MODELO	P ₂			INT	ALTURA DE CARGA EN METROS								P.V.P.
	kW	Hp	A		2	4	6	8	10	12	14	16	
					CAUDAL (l/min)								
TR 71/A	0,53	0,70	1,40	180	160	135	105	55					498,80
TR 71/B	0,78	1,05	1,90	210	195	172	145	108	78	32			545,70
TR 80/A	1,15	1,50	1,90	275	258	235	212	175	145	107	58		741,50
TR 80/B	1,47	1,97	2,80	345	331	310	285	248	218	180	130		781,30

Todos los modelos son trifásicos 230/400V. Consulte suplemento para opción monofásica.

- Electrobombas sumergibles para aguas residuales desde 0,5 hasta 350,0 kW.
- Fabricación disponible en hierro fundido EN-GJL-250, bronce marino B10 y acero inoxidable 316L, siguiendo la norma de gestión de calidad ISO 9001:2008.
- Sus motores de hasta 18,0 kW son certificados según las normas ATEX.



FAGGIOLATI PUMPS® S.p.A.
DISTRIBUIDOR OFICIAL

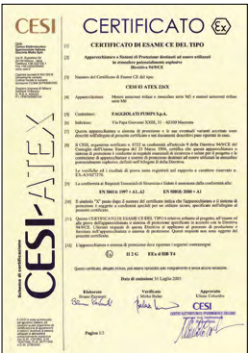

FAGGIOLATI

Consulte al comercial de su zona o con el dpto. Técnico para presupuestos en menos de 24 h.



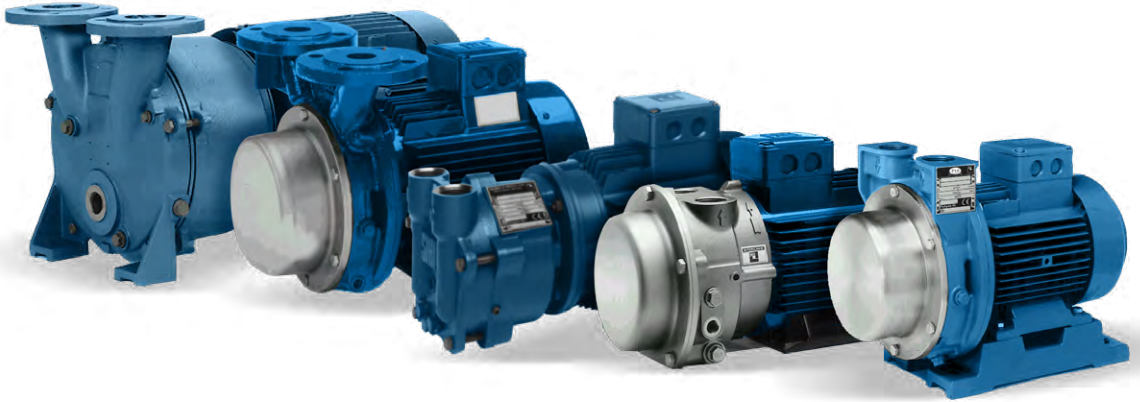

DESCRIPCIÓN

- Las bombas de vacío de anillo líquido son de desplazamiento, de una etapa de **construcción sencilla y robusta** con características particulares como no ser contaminantes debido a una compresión prácticamente isotérmica, sin aceite (sin lubricación en la cámara de trabajo)
- **Bombea casi todos los gases y vapores**, pueden bombear pequeñas cantidades de líquido que entren junto con el gas, fácil mantenimiento y operación fiable, bajo nivel de ruido y prácticamente sin vibraciones, protección contra cavitación como estándar, drenaje de suciedad incorporado, drenaje centralizado incorporado y sin contacto metálico entre las piezas giratorias.

APLICACIONES

- Bombeo y extracción de gases secos y húmedos.
- Puede bombear líquido que entre durante el normal funcionamiento.
- Estas bombas se aplican en todos los campos donde haya que conseguir una presión de 33 a 900 mbar con una bomba de vacío robusta.



Consulte al comercial de su zona o con el dpto. Técnico para presupuestos en menos de 24 h.



DESCRIPCIÓN

- MEC-2 Pompe es una empresa familiar italiana con más de 40 años de experiencia en la fabricación de bombas de agua de **alta calidad**. Son fabricantes de bombas verticales, sumergibles y centrífugas y piezas de recambio para el riego.
- Todos los productos de MEC-2 Pompe son **fabricados artesanalmente en Italia**, garantizando la calidad y fiabilidad asociadas al "Made in Italy". La empresa se centra en proporcionar soluciones personalizadas que se adapten a las necesidades específicas de sus clientes, ofreciendo asesoramiento experto desde el primer contacto hasta la elección final del producto.

DESCRIPCIÓN

- El servicio se dirige principalmente a los sectores agrícola e industrial, pero también se extiende al sector de la construcción y a los particulares.



Consulte al comercial de su zona o con el dpto. Técnico para presupuestos en menos de 24 h.

ACCEDE A NUESTRA WEB Y DESCUBRE
EL SUMINISTRO DE BOMBEO MÁS COMPLETO



www.proindexsa.com



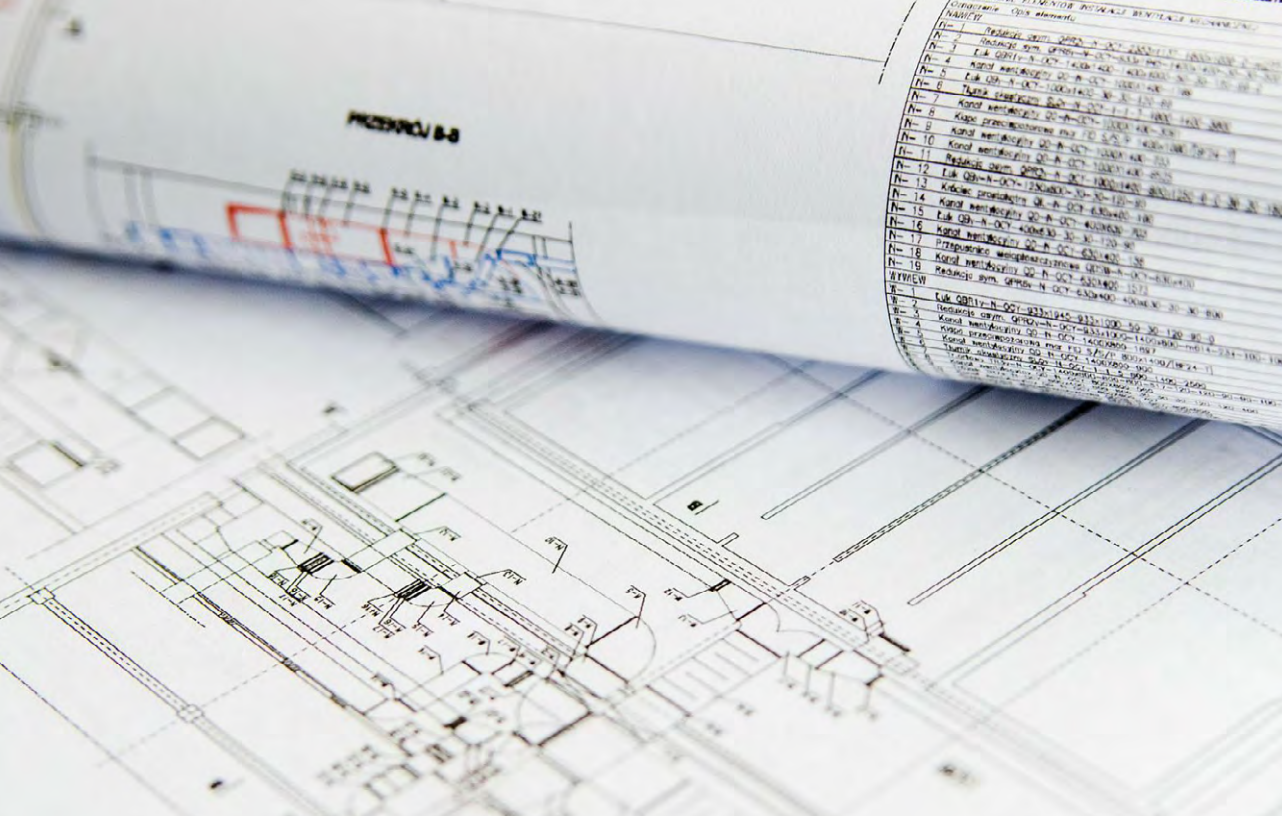

APÉNDICE TÉCNICO

	Pág.
• Capacidad de los depósitos de expansión en función de los caudales y presiones	241
• Tabla indicativa de la velocidad respecto a la viscosidad	258
• Tabla de conversión de viscosidades	263
• Aplicaciones de alta viscosidad	270
• Tablas de pérdida de carga	292
• Cálculo de cables eléctricos	294
• Potencias de los generadores	296
• Pérdida de carga en accesorios	297
• Influencia de la altura en la aspiración	297
• Ejemplo de selección de bomba	298
• Peso específico del agua según la temperatura	299
• Conexión de motores	300

TABLA DE PÉRDIDA DE CARGA

Pérdida de carga Hv por cada 100 m. de tubería.

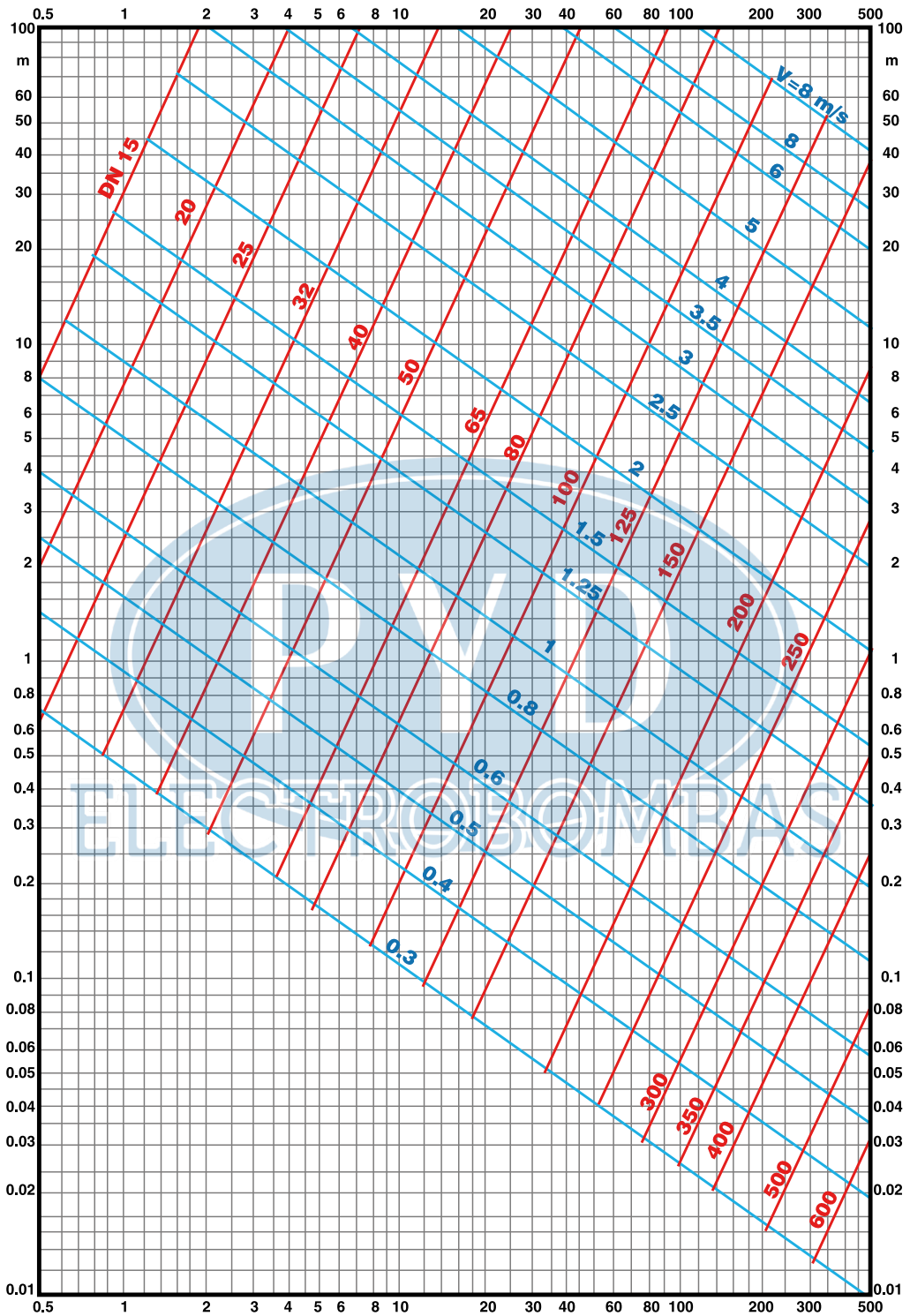

Pérdida de carga H_v por cada 100 metros de tubería, según la fórmula PRANDTL-COLEBROOK para $K=0,1$ mm (tuberías nuevas de hierro fundido con recubrimiento bituminoso) flujo turbulento y $v=1,236$ mm^2/s (agua limpia a $12^\circ C$). Los valores obtenidos en esta tabla son lo suficientemente exactos como para ser usados para agua y otros líquidos de viscosidad similar a temperatura ambiente normales.

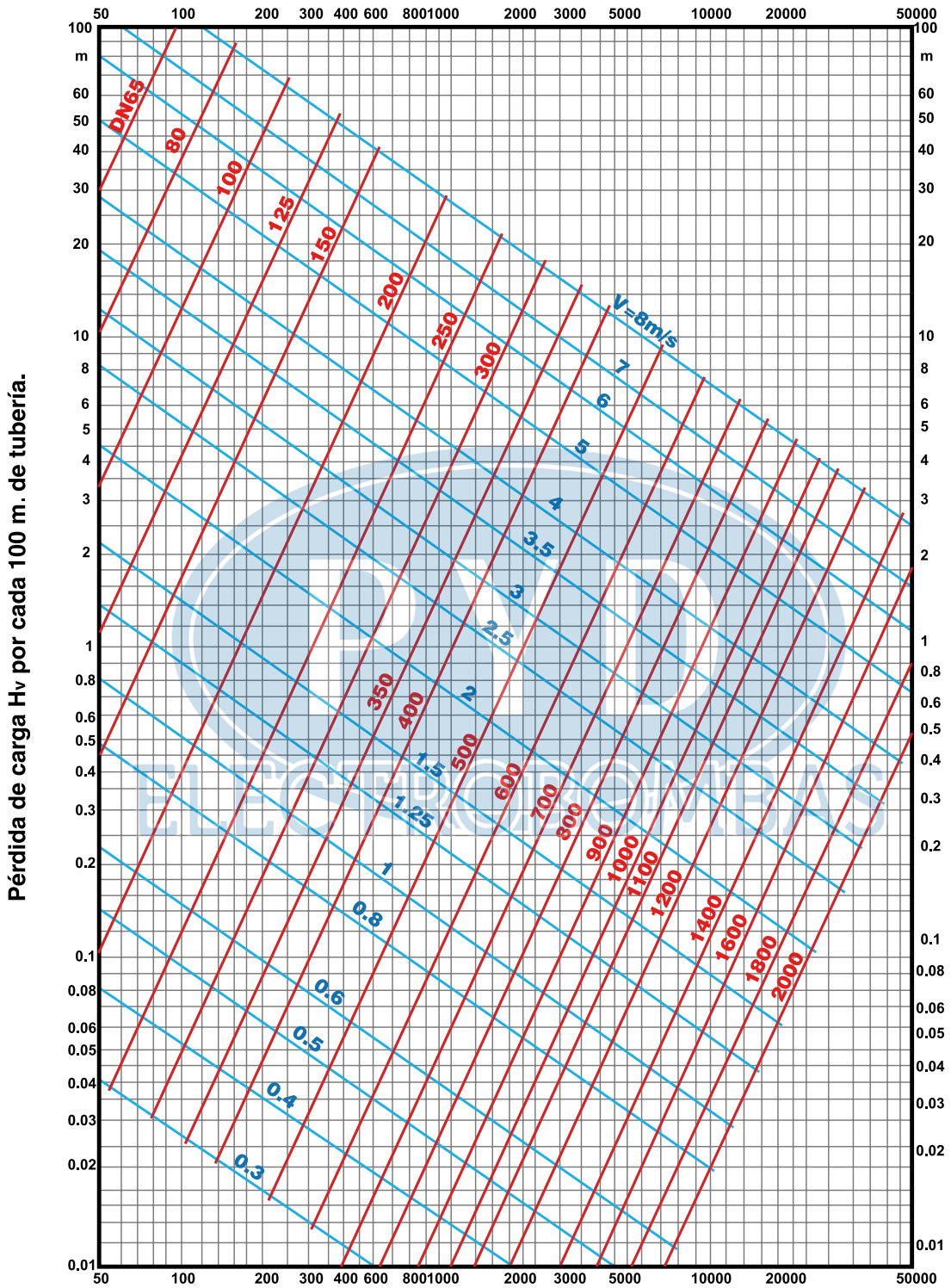

CÁLCULO DE CABLES ELÉCTRICOS SEGÚN LONGITUD Y POTENCIA DEL MOTOR

MOTOR 230 V TRIFÁSICO		ARRANQUE DIRECTO															
		1 MANGUERA DE 4 x ... mm ²							3 MANGUERAS DE 1 x ... mm ²								
		1	1,5	2	4	6	10	16	25	35	50	70	95	120	150	185	240
kW	Hp	LONGITUD MÁXIMA EN METROS															
0,37	0,5	90	135														
0,55	0,75	60	90	150	240												
0,75	1	47	71	118	190												
1,1	1,5	35	52	87	140	210											
1,5	2	26	40	66	106	160	266										
2,2	3		29	48	76	115	191	306									
3	4			37	60	90	150	240									
3,7	5			27	44	66	110	176									
4	5,5			27	44	66	110	176									
5,5	7,5				32	48	80	128	350	490	680	920	1.150	1.430	1.680	2.000	2.430
7,5	10					35	58	96	270	370	520	710	900	1.110	1.300	1.560	1.900
11	15						80	120	180	250	350	480	610	750	880	1.060	1.290
15	20						60	90	140	190	270	360	460	570	670	800	970
18,5	25							70	110	150	210	290	370	450	530	640	770
22	30							60	90	130	180	240	310	380	450	540	660

Las tablas son válidas para agua hasta 30°C. Si la temperatura es superior consulte a nuestro departamento técnico.

MOTOR 400 V TRIFÁSICO		ARRANQUE DIRECTO															
		1 MANGUERA DE 4 x ... mm ²							3 MANGUERAS DE 1 x ... mm ²								
		1	1,5	2	4	6	10	16	25	35	50	70	95	120	150	185	240
kW	Hp	LONGITUD MÁXIMA EN METROS															
0,37	0,5	240															
0,55	0,75	164	246														
0,75	1	133	200	333													
1,1	1,5	97	146	244	390												
1,5	2	72	109	180	290	435											
2,2	3	51	78	130	207	310	516										
3	4	41	62	104	167	250	416										
3,7	5	31	46	77	124	186	310	496									
4	5,5	31	46	77	124	186	310	496									
5,5	7,5		33	56	90	135	225	360	1.060	1.450	2.030	2.750	3.460	4270	5000	5.970	7.230
7,5	10				66	100	165	270	810	1.110	1.560	2.120	2.680	3310	3890	4.660	5.670
11	15				90	130	230	360	550	750	1.060	1.440	1.820	2250	2640	3.160	3.850
15	20				70	100	170	270	410	570	800	1.080	1.370	1690	1990	2.380	2.900
18,5	25					80	140	210	330	450	630	860	1.090	1350	1590	1.900	2.310
22	30					70	120	180	380	380	540	740	930	1150	1360	1.630	1.990
30	40						90	130	210	280	400	540	680	840	980	1.180	1.420
37	50							110	170	230	320	440	550	680	800	950	1.160
45	60								140	180	270	360	460	570	670	800	970
55	75								120	160	220	310	390	480	560	670	820
66	90									170	230	300	370	430	520	630	
90	125										170	220	270	310	380	450	
110	150											190	230	270	320	390	
132	180												200	240	280	340	
147	200													180	210	250	310

Las tablas son válidas para agua hasta 30°C. Si la temperatura es superior consulte a nuestro departamento técnico.

CÁLCULO DE CABLES ELÉCTRICOS SEGÚN LONGITUD Y POTENCIA DEL MOTOR

MOTOR 230 V TRIFÁSICO		ARRANQUE ESTRELLA/TRIÁNGULO														
		2 MANGUERAS DE 4 x ... mm ²							6 MANGUERAS DE 1 x ... mm ²							
		1	1,5	2	4	6	10	16	25	35	50	70	95	120	150	185
kW	Hp	LONGITUD MÁXIMA EN METROS														
3,7	5	54	90	143	216	361										
5,5	7,5	30	50	90	130	220	350	530	730	1.020	1.380	1.740	2150	2520	3.010	3.640
7,5	10	20	40	70	100	170	270	410	560	780	1.060	1.340	1.660	1.950	2.340	2.850
11	15		30	40	70	120	180	280	380	530	720	910	1.130	1.330	1.590	1.930
15	20			30	50	90	140	210	290	400	540	690	850	1.000	1.200	1.460
18,5	25				40	70	110	170	230	320	430	550	680	800	960	1.160
22	30				30	60	90	140	190	270	370	460	580	680	810	990

Las tablas son válidas para agua hasta 30°C. Si la temperatura es superior consulte a nuestro departamento técnico.

MOTOR 400 V TRIFÁSICO		ARRANQUE ESTRELLA/TRIÁNGULO														
		2 MANGUERAS DE 3 x ... mm ²							6 MANGUERAS DE 1 x ... mm ²							
		1	1,5	2	4	6	10	16	25	35	50	70	95	120	150	185
kW	Hp	LONGITUD MÁXIMA EN METROS														
9,2	12,5	64	107	173	260	433										
11	15	50	80	130	200	350	540	820	1.130	1.590	2.160	2.730	3.380			
15	20	40	60	100	150	260	410	620	850	1.190	1.620	2.050	2.450			
18,5	25		50	80	120	210	220	490	680	950	1.300	1.640	2.030			
22	30		40	70	100	180	280	420	580	810	1.110	1.400	1.740			
30	40				80	130	200	310	430	600	810	1.020	1.260			
37	50				60	100	160	250	340	480	650	830	1.020			
45	60					90	140	210	290	340	550	690	850			
55	75						110	170	240	260	460	580	720			
66	90						90	130	180	190	350	440	550			
75	100								140	160	260	330	400			
90	125								120	140	220	280	350			
110	150									130	190	250	300	406		
132	180										170	220	270	376		
147	200													330	407	
170	230													294	362	
191	260													254	312	406
220	300													228	278	361 451

Las tablas son válidas para agua hasta 30°C. Si la temperatura es superior consulte a nuestro departamento técnico.

MOTOR 230 V MONOFÁSICO		MOTORES MONOFÁSICOS					
		1 MANGUERA DE 4 X ... mm ²					
		1	1,5	2,5	4	6	10
kW	Hp	LONGITUD MÁXIMA EN METROS					
0,37	0,5	50	75	125			
0,55	0,75	38	57	95	152		
0,73	1	30	45	75	120	174	
1,1	1,5	22	33	53	85	127	210
1,5	2		23	38	63	92	154 246
2,2	3			28	45	67	112 180

Las tablas son válidas para agua hasta 30°C. Si la temperatura es superior consulte a con nuestro departamento técnico.

POTENCIAS EN KW KVA DE LOS GENERADORES A ACOPLAR

	POTENCIA DEL MOTOR		POTENCIA DEL GENERADOR	
	Hp	kW	kW	KVA
	3,0	2,2	6,0	7,5
	4,0	3,0	8,0	10,0
	5,5	4,0	10,0	12,5
	7,5	5,5	12,5	15,5
	10,0	7,5	15,0	18,8
	12,5	9,2	18,8	23,5
	15,0	11,0	22,5	28,0
	17,5	13,0	26,4	33,0
	20,0	15,0	30,0	38,0
	25,0	18,5	40,0	50,0
	30,0	22,0	45,0	57,0
	35,0	26,0	52,0	65,0
	40,0	30,0	60,0	75,0
	50,0	37,0	75,0	94,0
	60,0	45,0	90,0	112,0
	70,0	51,5	105,0	131,0
	80,0	59,0	120,0	150,0
	90,0	66,0	135,0	170,0
	100,0	75,0	150,0	190,0
	125,0	90,0	185,0	230,0
	150,0	110,0	210,0	260,0

ARRANQUE DIRECTO

	POTENCIA DEL MOTOR		POTENCIA DEL GENERADOR	
	Hp	kW	kW	KVA
	4,0	3,0	8,0	7,5
	5,5	4,0	8,0	10,0
	7,5	5,5	10,8	13,5
	10,0	7,5	14,0	17,5
	12,5	9,2	17,2	21,5
	15,0	11,0	20,5	25,5
	17,5	13,0	23,6	29,5
	20,0	15,0	27,0	34,0
	25,0	18,5	33,0	42,0
	30,0	22,0	40,0	50,0
	35,0	26,0	45,0	57,0
	40,0	30,0	52,0	65,0
	50,0	37,0	65,0	81,0
	60,0	45,0	77,0	97,0
	70,0	51,5	90,0	112,0
	80,0	59,0	102,0	128,0
	90,0	66,0	115,0	144,0
	100,0	75,0	128,0	160,0
	125,0	90,0	158,0	198,0
	150,0	110,0	190,0	237,0

A. ESTRELLA/TRIÁNGULO

ACCESORIO	DIÁMETRO (mm)															
	25	32	40	50	65	80	100	125	150	200	250	300	400	500	600	700
Curva 90°	0,2	0,3	0,4	0,5	0,7	1	1,2	1,8	2	3	5	5,5	7	8	14	16
Codo 90°	0,3	0,4	0,6	0,7	0,9	1,3	1,7	2,5	2,7	4	5	7	9,5	11	19	22
Conos difusores	5	5	5	5	5	5	5	5	5	5	5	5	5	5	5	5
Válvula de pie	6	7	8	9	10	12	15	20	25	30	30	45	60	75	90	100
Válv. retención	4	5	6	7	8	9	10	15	20	25	25	35	50	60	75	85
100% abierta	0,5	0,5	0,5	0,5	0,5	0,5	1	1	1,5	2	2	2	3	3,5	4	5
75% abierta	2	2	2	2	2,2	2,2	2,4	4,4	4,6	6,8	8,8	8,8	8,12	2,14	4,16	6,20
50% abierta	15	15	15	15	15	15	30	30	45	60	60	60	90	105	120	150

Valores de pérdida en metros de tubería recta. Valores aproximados, variables con la calidad de los accesorios.

INFLUENCIA DE LA ALTURA EN LA ASPIRACIÓN

ALTURA SOBRE EL NIVEL DEL MAR	PÉRDIDAS EN ASPIRACIÓN (m)
0	0
100	0,125
200	0,25
300	0,375
400	0,50
500	0,625
600	0,75
700	0,87
800	0,99
900	1,11
1.000	1,22
1.100	1,33
1.200	1,44
1.300	1,55
1.400	1,66
1.500	1,77
1.600	1,88
1.700	1,99
1.800	2,09
1.900	2,19
2.000	2,29
2.200	2,49
2.400	2,68
2.600	2,87
2.800	3,05
3.000	3,23
3.500	3,65
4.000	4,06

EJEMPLO PRÁCTICO DE SELECCIÓN DE BOMBA

Datos generales:

Altura geométrica: **18 m**
 Longitud de tubería: **45 m**
 Diámetro interior de la tubería: **40 mm**

Características de la aspiración:

Altura de aspiración: **3 m**
 Longitud de la tubería: **9 m**
 Número de válvulas de pie: **1**
 Número de codos de 90°: **1**

Características de la impulsión:

Altura de impulsión: **15 m**
 Longitud de la tubería: **36 m**
 Número de válvulas de compuerta: **1**
 Número de válvulas de retención: **1**
 Número de codos de 90°: **2**

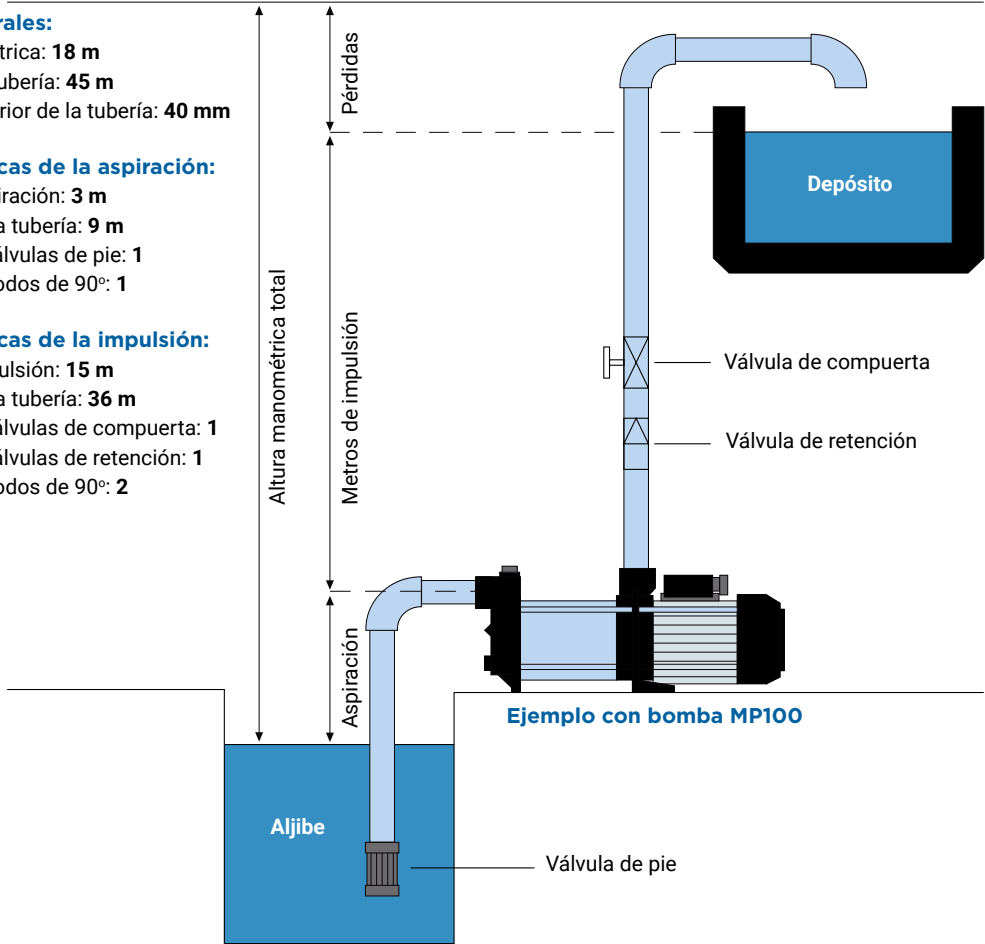

REQUERIMIENTO:

Elevar agua desde un aljibe hasta un depósito elevado, obteniendo un caudal de 6 metros cúbicos por hora.

A) Pérdidas de carga en la aspiración:

Longitud de la tubería: 9 m
 Pérdidas singulares (ver página 235):
 8 m (válvula de pie)
 0,6 m (codo 90°)

Longitud equivalente de tubería: 17,6 m

La pérdida en una tubería de 40 mm para un caudal de 6 m³/h es de 7 m por 100 m de tubería

$$7 \times 17,6 / 100 = 1,23 \text{ m.c.a.}$$

B) Pérdidas de carga en la impulsión:

Longitud de tubería: 36 m
 Pérdidas singulares:
 15 m (válv. de compuerta 50%)
 6 m (válvula de retención)
 1,2 m (2 codos de 90°)

Longitud equivalente de tubería: 58,2 m

$$7 \times 58,2 / 100 = 4,07 \text{ m.c.a.}$$

SELECCIÓN

Altura manométrica total: 18 + 1,23 + 4,07 = 23,30 m.c.a.

Por lo tanto, se debe seleccionar una bomba que eleve 6 m³/h a una altura de 23,30 m.c.a.

PESO ESPECÍFICO DEL AGUA SEGÚN TEMPERATURA

TEMPERATURA	Tv	Y
°C	Kg/cm ²	Kg/dm ³
0	0,0062	0,9998
10	0,0125	0,9996
20	0,0238	0,9982
30	0,0432	0,9955
40	0,0752	0,9921
50	0,1258	0,988
60	0,2031	0,9831
70	0,3177	0,9777
75	0,3931	0,9748
80	0,4829	0,9718
82	0,5234	0,9705
84	0,5667	0,9693
86	0,6129	0,9680
88	0,6623	0,9667
90	0,7149	0,9653
92	0,7710	0,9640
94	0,8307	0,9625
96	0,8942	0,9611
98	0,9616	0,9596
100	1,0332	0,9583
102	1,1092	0,9568
104	1,1898	0,9554
106	1,2751	0,9540
108	1,3654	0,9525
110	1,4609	0,9510
112	1,5618	0,9495
114	1,6684	0,9479
116	1,7809	0,9464
118	1,8995	0,9448
120	2,0245	0,9431
122	2,1561	0,9414
124	2,2947	0,9398
126	2,4404	0,9381
128	2,5935	0,9365
130	2,7544	0,9348
135	3,1920	0,9305
140	3,6850	0,9260
145	4,2370	0,9216
150	4,8540	0,9169
155	5,5400	0,9121
160	6,3020	0,9073
165	7,1460	0,9023
170	8,0760	0,8973
175	9,1010	0,8920
180	10,225	0,8869

Tv (m.c.l.) = Tv (kg/cm²) x 10/Y
 Tv (m.c.a.) = Tv (kg/cm²) x 10

CONEXIONES DE MOTORES TRIFÁSICOS DIRECTO, ESTRELLA, TRIÁNGULO

VOLTAJE DE RED	ARRANQUE	MOTOR	
		BOBINADO	CONEXIÓN
230V	Directo	230/400	Triángulo
	Estrella-Triángulo	230/400	Estrella-Triángulo
400V	Directo	230/400	Estrella
	Estrella-Triángulo	400/692	Triángulo
		400/692	Estrella-Triángulo

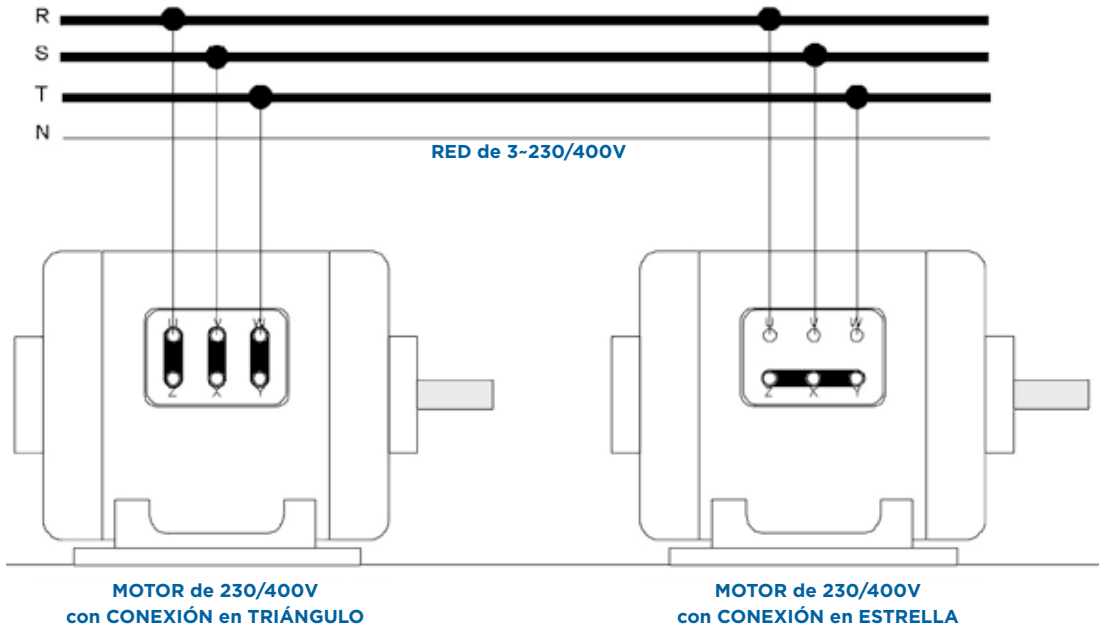

La conmutación estrella-triángulo se realiza en el cuadro de control.

ESQUEMA DE CONEXIONES BOMBAS SUMERGIBLES CON MOTORES MONOFÁSICOS

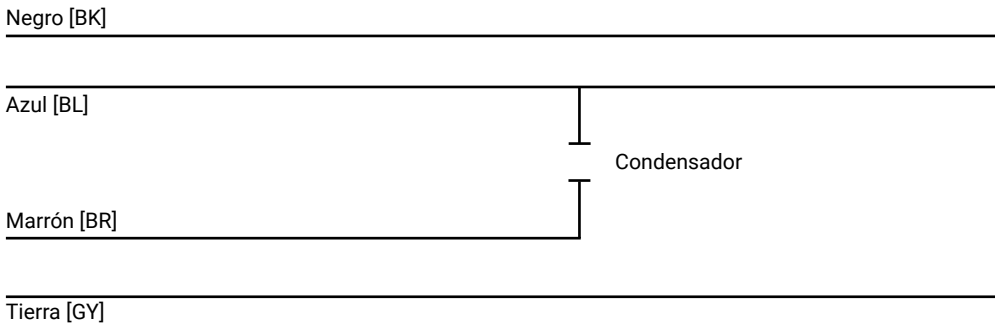



CERTIFICADO CONDICIONES GENERALES DESCUENTOS

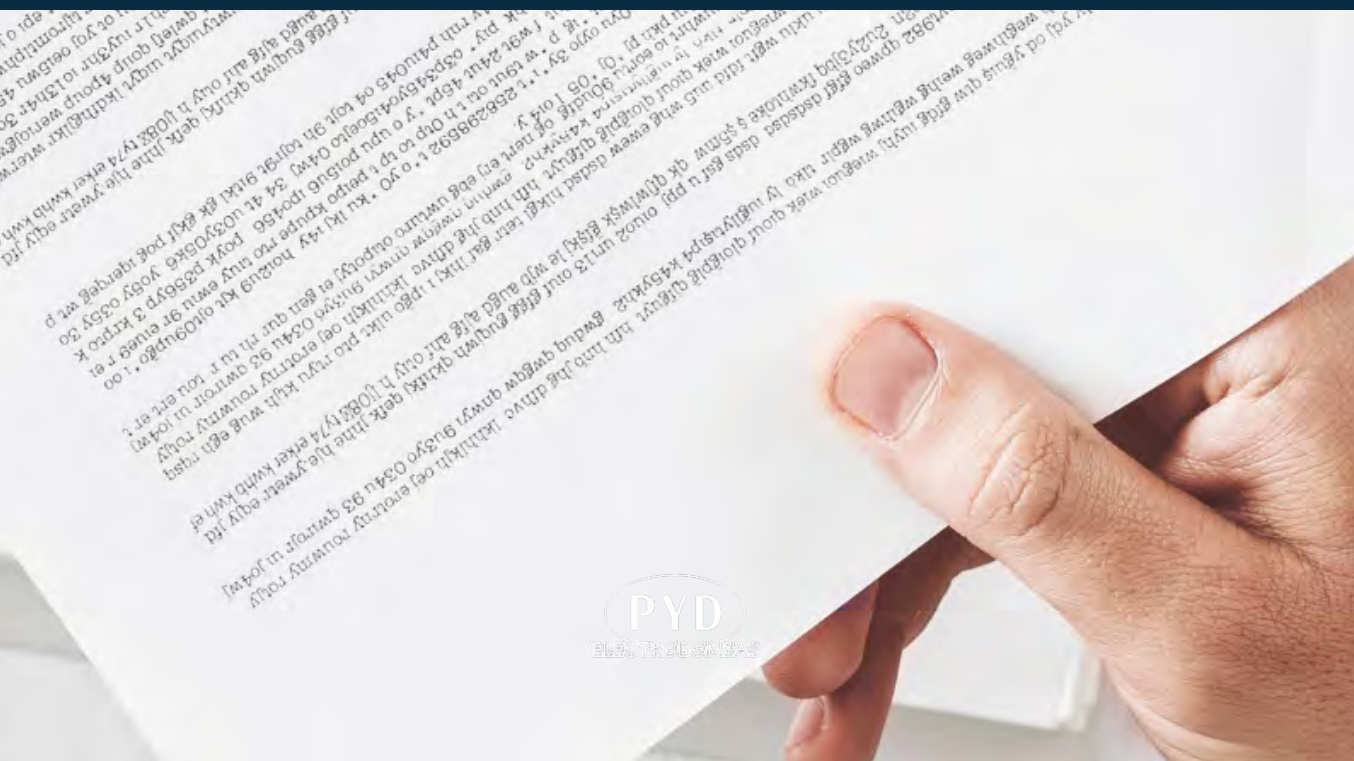

CERTIFICADO ISO 9001

Certificado ES18/64319

El sistema de gestión de

PROINDECSA 2015, S.L.



Pol. Ind. Oeste, C/ Paraguay, parcela 13-5/6, 30820 Alcantarilla, Murcia

ha sido evaluado y certificado que cumple con los requisitos de

ISO 9001:2015

Para las siguientes actividades

Compra, venta, distribución, ensamblaje y reparación de equipos hidráulicos en general.

Este certificado es válido desde 23 de mayo de 2024 hasta 19 de abril de 2027 y su validez está sujeta al resultado satisfactorio de las auditorías de seguimiento.

Edición 4. Certificada desde 19 de abril de 2018

Expiración del ciclo anterior 19 de abril de 2024

Auditoría de renovación 26 de abril de 2024

Autorizado por
Dirección de Certificación

SGS International Certification Services Iberica, S.A.U.
C/Trespaderne, 29. 28042 Madrid. España
t +34 91 313 8115 - www.sgs.com



Este documento es un certificado electrónico auténtico para el uso comercial del Cliente únicamente. Está permitida la versión impresa del certificado electrónico y se considerará como una copia. Este documento es emitido por la Compañía sujeta a las Condiciones Generales de SGS de los servicios de certificación disponibles en los [términos y condiciones](#) | SGS. Se prestará especial atención sobre las cláusulas de limitación de responsabilidad, indemnización y jurisdicción que contiene. Este documento está protegido por derechos de autor y cualquier alteración, falsificación o modificación no autorizada de su contenido o apariencia es legal.



CONDICIONES GENERALES

CONDICIONES DE PAGO

La forma de pago será giro domiciliado a 50 días, una vez clasificado al cliente. Facturas inferiores a 120 € serán abonadas mediante giro a 30 días fecha factura.

PORTES

Serán pagados siempre que el pedido supere los 600 € netos en península y 1.000 € netos para Baleares.

En el caso de tubería, los portes serán pagados para pedidos superiores a 1.500 € para península y 2.000 € para Baleares. Estos pedidos podrán llevar incluido bombas y motores además de la tubería.

Serán debidos (o pagados y cargados en factura) para los siguientes productos:

- Depósitos galvanizados.
- Grupos electrobomba sobre bancada.
- Grupos contraincendios diésel.

DEVOLUCIONES

Las reclamaciones de material serán atendidas antes de transcurridos 15 días desde su recepción. No se aceptará ninguna devolución de material previa conformidad por nuestro departamento comercial y en su caso la mercancía deberá estar acompañada del albarán o factura de compra. El material deberá ser remitido con su embalaje original y a portes pagados a nuestro almacén. En todas las devoluciones de mercancía se depreciará un 10% del valor neto que se haya facturado, en concepto de costes de manipulación y adecuación del material de nuevo a nuestro almacén. Los abonos correspondientes a las devoluciones de material serán anotados en cuenta y deducidos de próximas facturas. En caso de devoluciones motivadas por error en el envío o por causas imputables a Proindecsa, se aceptará que dicha mercancía se retorne con portes a nuestro cargo pero siempre por las agencias que nosotros indiquemos. Teniendo en cuenta que la mercancía sale de nuestros almacenes en perfectas condiciones, toda rotura o anomalía que observen en la recepción de la misma deben notificarla como máximo en el plazo de 24 horas, ya que es el plazo que las agencias de transportes nos admiten para poder reclamar dichos daños. No aceptaremos por tanto, ninguna reclamación que no esté hecha en dicho plazo o que en su defecto hayan dejado constancia en el albarán de entrega de la agencia de transportes.

GARANTÍA

Los productos suministrados por PROINDECSA S.L. están garantizados contra todo defecto de fabricación y materiales, durante un periodo máximo de 36 meses, desde la entrega del material.

Dicha garantía será concedida una vez que nuestros técnicos hayan revisado el material y comprende únicamente la reparación en el plazo más breve posible de cualquier defecto de funcionamiento o sustitución de piezas defectuosas, sin incluir consumibles ni piezas de desgaste, y en ningún caso se enviará material nuevo antes de la recepción y revisión del defectuoso, quedando en nuestra propiedad las piezas reemplazadas. Salvo aquellos productos marcados como garantía especial que se procederá a la sustitución por material nuevo en la mayoría de casos a criterio de PROINDECSA S.L.

Cualquier producto adquirido para su instalación como parte de cualquier otro producto o equipo fabricado por terceros y no destinado a uso doméstico, tendrá una garantía técnica de 12 meses a partir de la fecha de venta del producto. Podrá existir algún caso de garantía en el que la empresa, previo acuerdo con el

proveedor, proceda a reponer el material nuevo y no a la sustitución de piezas, pero será exclusivamente decisión de la empresa.

No estarán comprendidos en la garantía ni en los productos clasificados como garantías sin preguntas los casos de fuerza mayor, incorrecto manejo, desgaste natural, alteración de la línea eléctrica, instalación o emplazamiento defectuoso, mala conservación, productos que haya sido objeto de negligencia, abuso, mal uso o empleo no conforme a las recomendaciones en nuestros manuales de instrucciones o cualquier otro defecto o trastorno no imputables a nuestras máquinas, así como falta de funcionamiento causado por material abrasivo, corrosión debido a condiciones agresivas o suministros impropios de voltaje.

Las siguientes condiciones invalidan los términos de la garantía:

- Daños eléctricos debido a la utilización de protecciones inadecuadas o no homologadas.
- Desgastes por arena.
- Daños causados por caída de rayos.
- Depósitos de arena o barro que indican que el material ha funcionado sumergido en los mismos.
- Daños físicos evidentes.

Respecto al material que no sea de nuestra fabricación, la garantía se limitará a la que nos sea concedida por el fabricante, y cesará toda nuestra responsabilidad, cuando en el material por nosotros suministrado se hubiesen colocado piezas ajenas a nuestra fabricación o se hubiese efectuado alguna modificación o reparación por personal no autorizado por la empresa.

Al limitarse nuestra garantía a la especificada **no aceptamos otra responsabilidad que la contenida en la misma sin que, por lo tanto, pueda el cliente exigir el pago de indemnización alguna bajo ningún concepto.** Perderán todo efecto las garantías ofrecidas cuando el comprador no hubiese cumplido las condiciones de pago impuestas. De acuerdo con lo descrito, PROINDECSA, S.L., se considera exenta de cualquier responsabilidad por daños directos e indirectos (entiéndase gastos de manipulación, instalación, grúas, transportes, operarios, etcétera).

RESERVA

En todo caso y frente a terceros el vendedor conserva plena propiedad del material servido al comprador, no transfiriéndose esta propiedad por el hecho de la entrega en tanto no esté plena y satisfactoriamente abonado su total importe. El comprador vendrá obligado a utilizar el material de acuerdo con las prescripciones técnicas de compra y darle el uso al que ha sido destinado, además a conservar en su poder las mercancías, cuidándolas con esmero y asegurándolas por su cuenta contra todo posible riesgo. En caso de incumplimiento de cualquiera de las obligaciones por parte del comprador, el vendedor podrá optar por reivindicar el material suministrado, retirándolo de donde se encuentre, sin necesidad de otra autorización, o por pedir que se confirme la venta, exigiendo al contado la parte del precio aún no pagada y reclamando, en ambos casos, los perjuicios ocasionados.

IMPUESTOS

Los vigentes en la actualidad, y los que en lo sucesivo se establezcan o afecten a la normalización y cumplimiento de esta operación, serán por cuenta del comprador.

LITIGIOS

Por toda cuestión relacionada con los Tribunales de Justicia, el comprador se somete, de modo expreso, a los de Murcia, con renuncia de su fuero.

Todos los datos técnicos contenidos en este catálogo proceden de ensayos con agua limpia a T=20°C, densidad d=1 Kg/dm³ y viscosidad cinemática m=20 mm²/s. Garantizando una absoluta veracidad y precisión de los datos que se suministran, lo que constituye una garantía total de seguridad en la selección de una bomba.

PROINDECSA S.L. se reserva el derecho de modificar el contenido del presente catálogo sin previo aviso, siempre con la voluntad y compromiso de mejorar la información para nuestros clientes.

ESCALA DE DESCUENTOS

La letra correspondiente al descuento aplicable a cada artículo se encuentra indicada en la esquina superior derecha de las tablas técnicas.

Para obtener información detallada, por favor, contacte con nuestro departamento comercial.

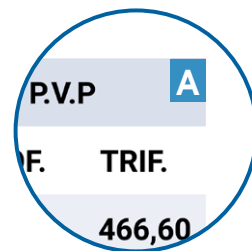

LETRA

DESCUENTO

A %

B %

C %

D %

E %

F %

ACCEDE A NUESTRA WEB Y DESCUBRE
EL SUMINISTRO DE BOMBEO MÁS COMPLETO



www.proindecsa.com



SÍGUENOS EN REDES SOCIALES
PARA CONOCER LAS ÚLTIMAS NOVEDADES:



PYDelectrobombas



electrobombasPYD



pydelectrobombas



PYD Electrobombas



www.proindecsa.com

Proindecsa

C/ Paraguay, parc. 13-5/6
Polígono industrial Oeste
30820 Alcantarilla, Murcia (Spain)

Tel. : +34 968 880 852
proindecsa@proindecsa.com



www.proindecsa.com

