

# PYD

## ELECTROBOMBAS

### SERIE

# NTZ

**DE ACHIQUE SUMERGIBLE**  
SUBMERSIBLE DEWATERING PUMP  
POMPE DE DRAINAGE SUBMERSIBLE



## CATÁLOGO TÉCNICO

TECHNICAL CATALOGUE  
CATALOGUE TECHNIQUE

## 1. DESCRIPCIÓN DESCRIPTION DESCRIPTION

Bomba de achique sumergible con motor de 4 polos para mayor vida útil y comodidad. Impulsor de aleación de alto contenido en cromo combinado con agitador para bombear lodos pesados. Refrigeración con agua para permitir que la bomba funcione a niveles bajos de agua. Útil para ingeniería civil, minas, canteras, etc.

✿ Submersible dewatering pump with 4-pole motor for extended lifespan and convenience. High-chrome alloy impeller combined with agitator for pumping heavy sludge. Water cooling to enable operation at low water levels. Useful for civil engineering, mines, quarries, etc.

🇫🇷 Pompe de drainage submersible avec moteur à 4 pôles pour une durée de vie prolongée et un confort accru. Impulseur en alliage à haute teneur en chrome combiné à un agitateur pour pomper les boues lourdes. Refroidissement à l'eau pour permettre le fonctionnement à des niveaux d'eau bas. Utile pour le génie civil, les mines, les carrières, etc.



### MATERIALES

**Cuerpo de bomba:** Fundición  
**Cuerpo del motor:** Fundición  
**Rejilla:** Acero  
**Impulsor:** Aleación de cromo  
**Cierre mecánico:** Sic-Sic/Sic-Sic  
**Cable:** 8 m

### ✿ MATERIALS

**Pump body:** Cast Iron  
**Motor body:** Cast Iron  
**Grid:** Steel  
**Impeller:** Chromium alloy  
**Mechanical seal:** Sic-Sic/Sic-Sic  
**Cable:** 8 m

### 🇫🇷 MATÉRIELS

**Corps de la pompe:** Fonte  
**Corps du moteur:** Fonte  
**Grille:** Acier  
**Roue:** Alliage de chrome  
**Joint mécanique:** Sic-Sic/Sic-Sic  
**Câble:** 8 m

### ÁREA DE TRABAJO

**Temperatura máx. del líquido:** 40°C  
**Grado de protección:** IP68  
**Aislamiento clase:** F  
**Profundidad máx. de inmersión:** 20 m

### ✿ WORKING RANGE

**Maximum liquid temperature:** 40°C  
**Protection rating:** IP68  
**Insulation class:** F  
**Maximum immersion depth:** 20 m

### 🇫🇷 PLAGUE DE TRAVAIL

**Température maximale du liquide:** 40°C  
**Indice de protection:** IP68  
**Classe d'isolation:** F  
**Profondeur maximale d'immersion:** 20 m

## 2. CURVAS CURVES COURBES

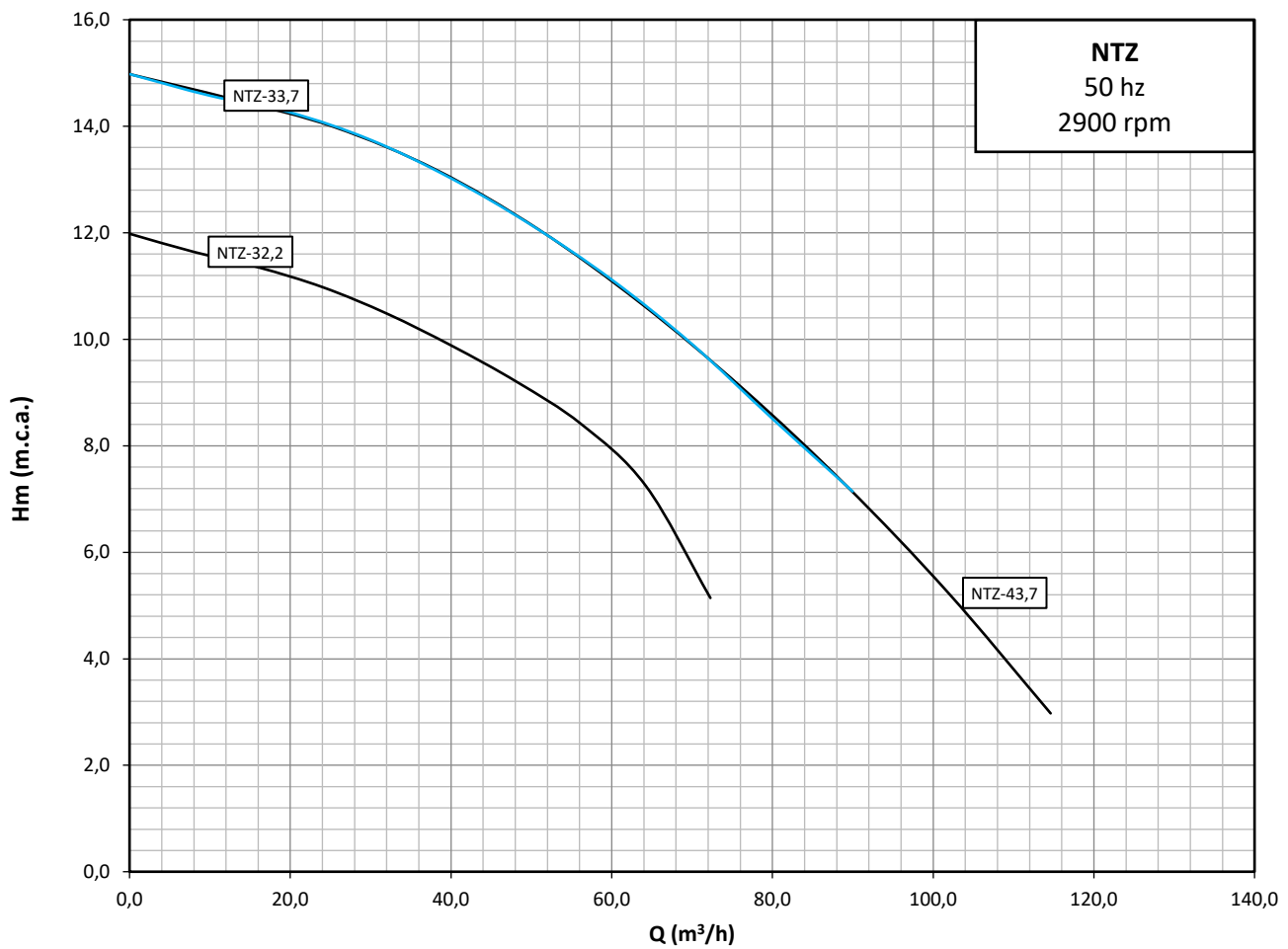

MODELO MODEL MODÈLE	P <sub>2</sub>		DN	SÓLIDOS PESO		CAUDAL FLOW DÉBIT											
	kW	Hp		mm	mm	Kg	m³/h	l/min	0	15	30	45	60	75	90	105	
NTZ-32.2	2,2	3,0	80	20	99,0	ALTURA DE CARGA EN METROS			LOADING HEIGHT IN METRES			HAUTEUR DE CHARGEMENT EN MÈTRES					
NTZ-33.7	3,7	5,0	80	20	116,0	12,0	11,5	10,5	9,5	8,0	15,0	14,5	13,8	12,6	11,2	9,3	7,0
NTZ-43.7	3,7	5,0	100	20	116,0	15,0	14,5	13,8	12,6	11,2	9,3	7,0	4,5				

### 3. MEDIDAS MEASURES MESURES

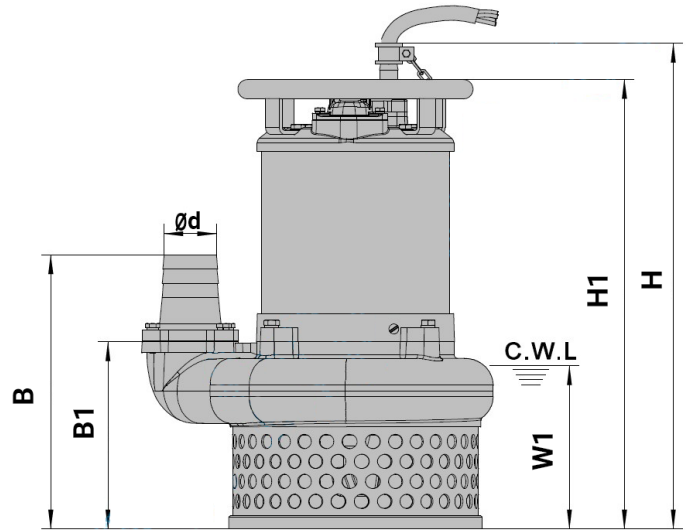
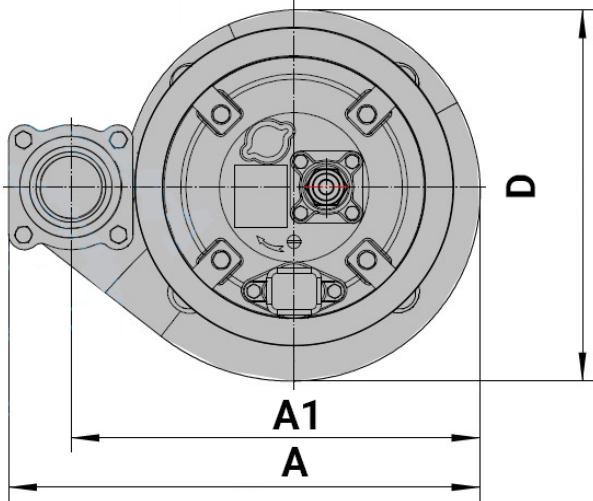

MODELO MODEL MODÈLE	d	A	A1	B	B1	D	H	H1	W1	KG
NTZ-32.2	80	469	408	378	257	371	685	625	230	99
NTZ-33.7	80	469	408	378	257	371	750	690	230	116
NTZ-43.7	100	469	408	364	257	371	750	690	230	116

## 4. DESPIECE SPARE PARTS PIÈCES DE RECHANGE

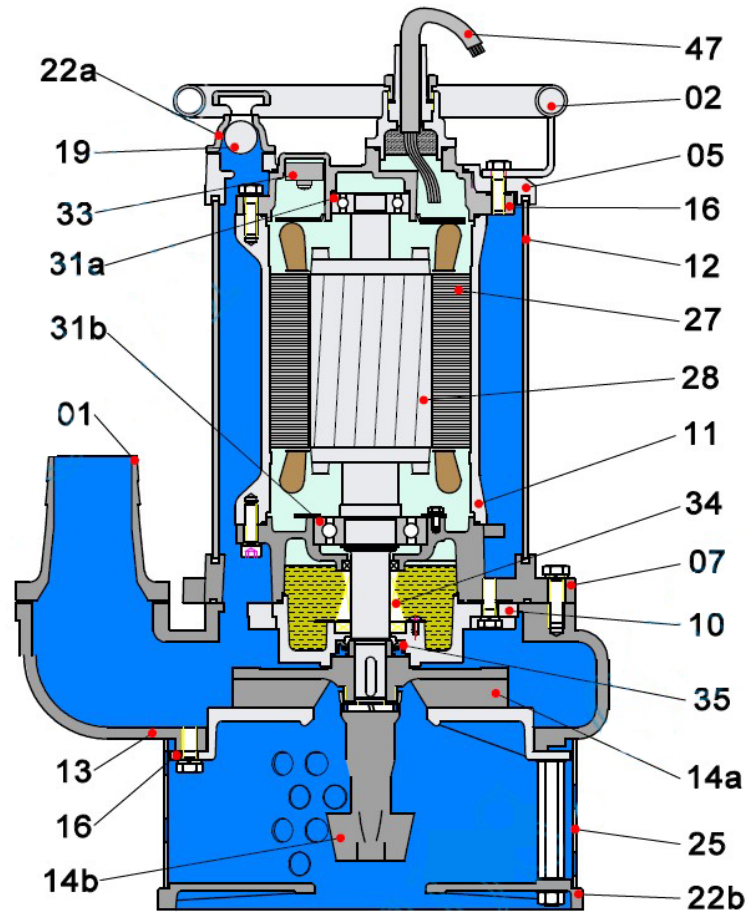

Nº	Nombre	Material
1	Acoplamiento de manguera	Hierro fundido
2	Asa	Acero
5	Cobertura superior	Hierro fundido
6	Carcasa de rodamiento superior	Hierro fundido
7	Carcasa de rodamiento	Hierro fundido
10	Casa del sello	Hierro fundido
11	Cuerpo del motor	Hierro fundido
12	Carcasa externa	Acero
13	Cuerpo de la bomba	Hierro fundido
14a	Impulsor	Aleación de cromo alto
14b	Agitador	Aleación de cromo alto
16	Placa de entrada	Hierro dúctil

Nº	Nombre	Material
19	Válvula de retención	NBR
22a	Asiento de válvula	Hierro fundido
22b	Conjunto de asiento	Hierro fundido
25	Colador	Acero
27	Estátor	-
28	Rotor	Eje: AISI 420
31a	Rodamiento	Rodamiento de bolas
31b	Rodamiento	Rodamiento de bolas
33	Protector del motor	
34	Cierre mecánico	Sic-Sic/Sic-Sic
35	Sello de aceite	
47	Cable	

## 4. DESPIECE SPARE PARTS PIÈCES DE RECHANGE

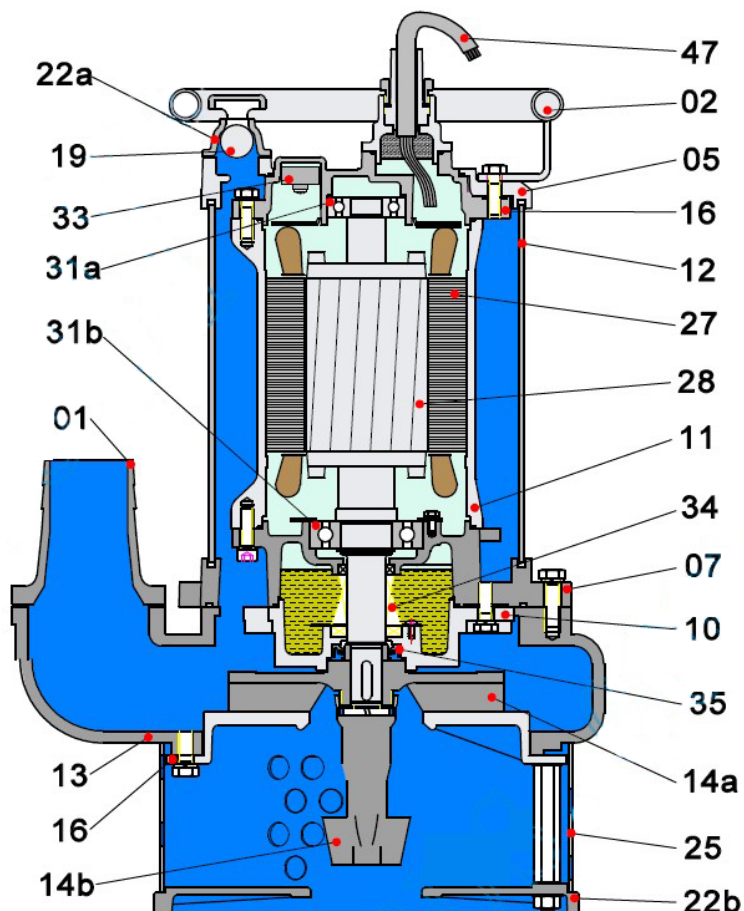

N°	Nombre	Material
1	Hose coupling	Cast iron
2	Handler	Steel
5	Upper cover	Cast iron
6	Up-bearing house	Cast iron
7	Bearing house	Cast iron
10	Seal house	Cast iron
11	Motor body	Cast iron
12	Outer casing	Steel
13	Pump body	Cast iron
14a	Impeller	High chrome alloy
14b	Agitator	High chrome alloy
16	Inlet plate	Ductile iron

N°	Nombre	Material
19	Check valve	NBR
22a	Valve seat	Cast iron
22b	Seat assembly	Cast iron
25	Strainer	Steel
27	Stator	-
28	Rotor	Shaft: AISI 420
31a	Bearing	Ball bearing
31b	Bearing	Ball bearing
33	Motor protector	
34	Mechanical seal	Sic-Sic/Sic-Sic
35	Oil seal	
47	Cable	

## 4. DESPIECE SPARE PARTS PIÈCES DE RECHANGE

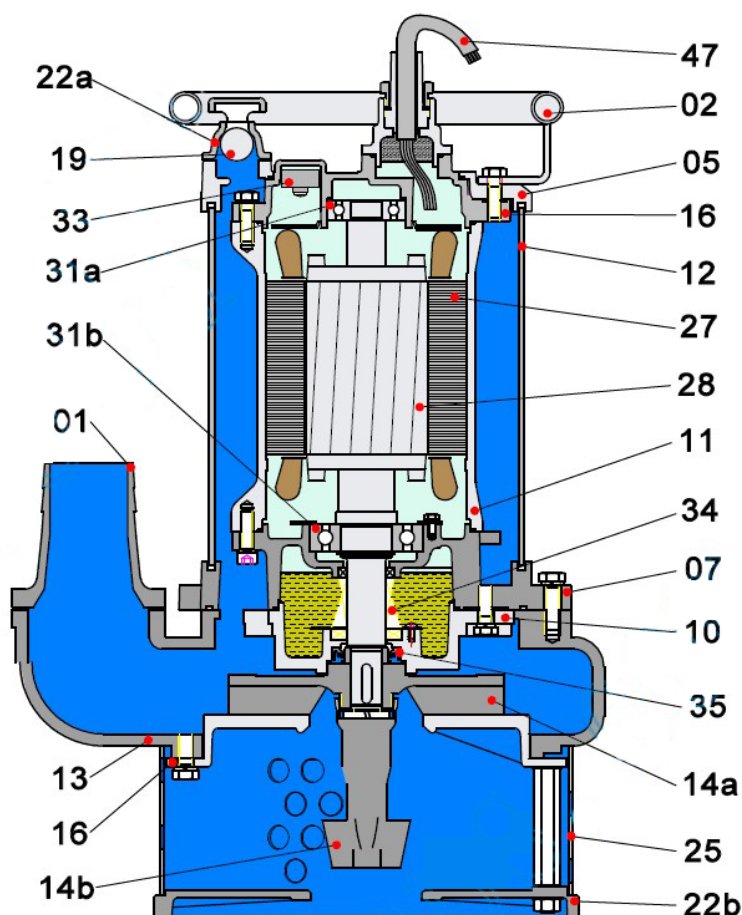

N°	Nombre	Material
1	Raccord de tuyau	Fonte
2	Handler	Acier
5	Couvercle supérieur	Fonte
6	Boîtier de palier supérieur	Fonte
7	Boîtier de roulement	Fonte
10	Boîtier de joint	Fonte
11	Corps de moteur	Fonte
12	Boîtier externe	Acier
13	Corps de pompe	Fonte
14a	Roue	Alliage haute teneur en chrome
14b	Agitateur	Alliage haute teneur en chrome
16	Plaque d'entrée	Fonte ductile

N°	Nombre	Material
19	Clapet anti-retour	NBR
22a	Siège de soupape	Fonte
22b	Assemblage de siège	Fonte
25	Passoire	Acier
27	Stator	-
28	Rotor	Arbre: AISI 420
31a	Roulement	Roulement à billes
31b	Roulement	Roulement à billes
33	Motor protecteur	
34	Garniture mécanique	Sic-Sic/Sic-Sic
35	Joint d'huile	
47	Câble	

# Proindecsa

C/ Paraguay, parc. 13-5/6  
Polígono industrial Oeste  
30820 Alcantarilla, Murcia (Spain)

Tel. : +34 968 880 852  
proindecsa@proindecsa.com

[www.proindecsa.com](http://www.proindecsa.com)



🇪🇸 Proindecsa S.L. no se hace responsable de los posibles errores u omisiones que pueda contener este catálogo, ni de los daños o perjuicios que puedan derivarse de su uso. Proindecsa S.L. se reserva el derecho de modificar o actualizar el contenido de este catálogo en cualquier momento y sin previo aviso.

✳️ Proindecsa S.L. shall not be liable for any errors or omissions that this catalogue may contain, nor for any damages that may arise from its use. Proindecsa S.L. reserves the right to modify or update the contents of this catalogue at any time and without prior notice.

