

PYD

ELECTROBOMBAS

SERIE

BLOW

BOMBA SOPLANTE

BLOWER PUMP

POMPE DE SOUFFLE

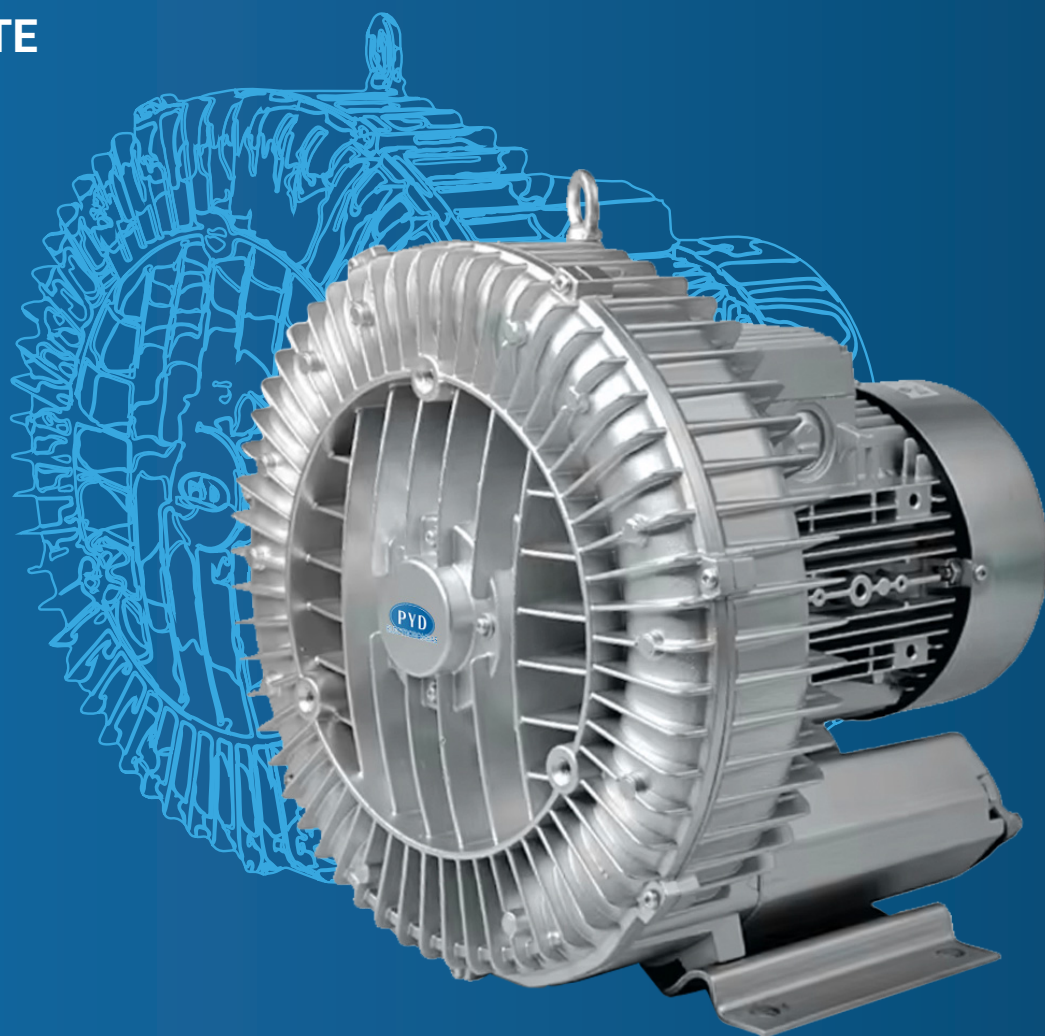

CATÁLOGO TÉCNICO

TECHNICAL CATALOGUE

CATALOGUE TECHNIQUE

1. DESCRIPCIÓN DESCRIPTION DESCRIPTION

Bombas soplantes fabricadas en aluminio de alta calidad. Destinadas para aplicaciones tanto domésticas como piscinas, baños de burbujas, extractores de humos. También son aptas para aplicaciones industriales como secado rápido, aspiración, limpieza de gases, etc. Gracias a su diseño no requieren de mantenimiento.

✿ Blower pumps made of high quality aluminium. Designed for domestic applications such as swimming pools, bubble baths, fume extractors. They are also suitable for industrial applications such as fast drying, suction, gas cleaning, etc. Thanks to their design, they do not require maintenance.

🇫🇷 Pompes soufflantes fabriquées en aluminium de haute qualité. Conçues pour des applications domestiques telles que les piscines, les bains à bulles, les extracteurs de fumées. Elles conviennent également aux applications industrielles telles que le séchage rapide, l'aspiration, le nettoyage des gaz, etc. Grâce à leur conception, elles ne nécessitent pas d'entretien.



MATERIALES

Cuerpo: Aluminio
Turbina: Aluminio
Eje: Acero 45 (cojinete de alta temperatura)
Base: Hierro

✿ MATERIALS

Body: Aluminium
Turbine: Aluminium
Shaft: Steel 45 (high temperature bearing)
bearing)
Base: Iron

🇫🇷 MATÉRIELS

Corps: Aluminium
Turbine: Aluminium
Arbre: Acier 45 (palier haute température palier)
Base: Fer

ÁREA DE TRABAJO

Resistencia al calor: Hasta 180°
Trabajo horizontal: Admitido
Compatible con la mayoría de gases.
Aire, oxígeno y CO².

✿ WORKING RANGE

Heat resistance: Up to 180°
Horizontal work: Admitted
Compatible with most gases
Air, oxygen and CO²

🇫🇷 PLAGUE DE TRAVAIL

Résistance à la chaleur : Jusqu'à 180°
Travail horizontal : Admis
Compatible avec la plupart des gaz
Air, oxygène et CO²

2. CURVAS CURVES COURBES

BLOW-370

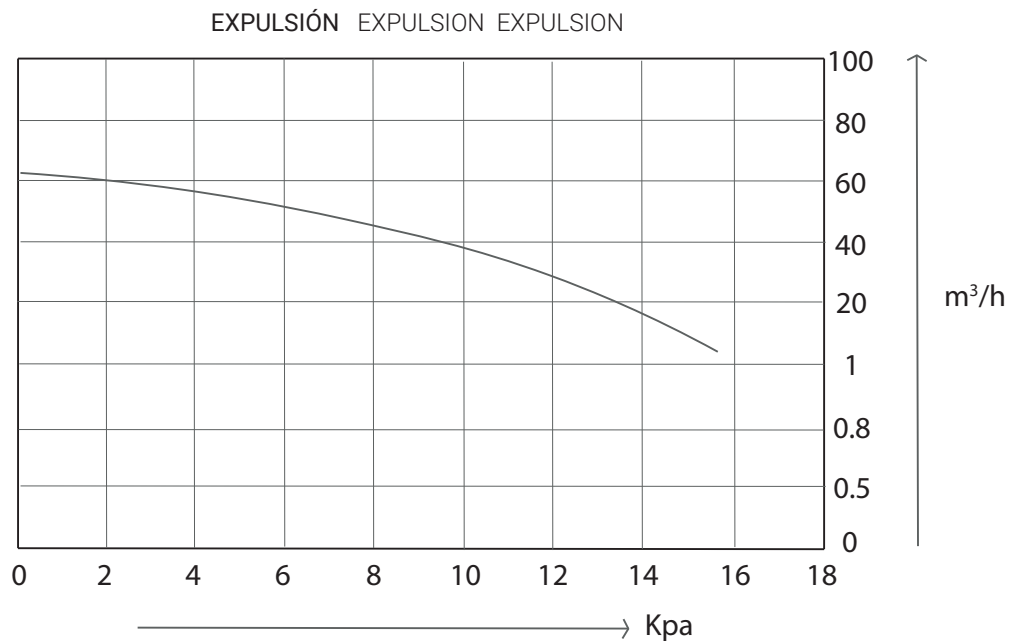
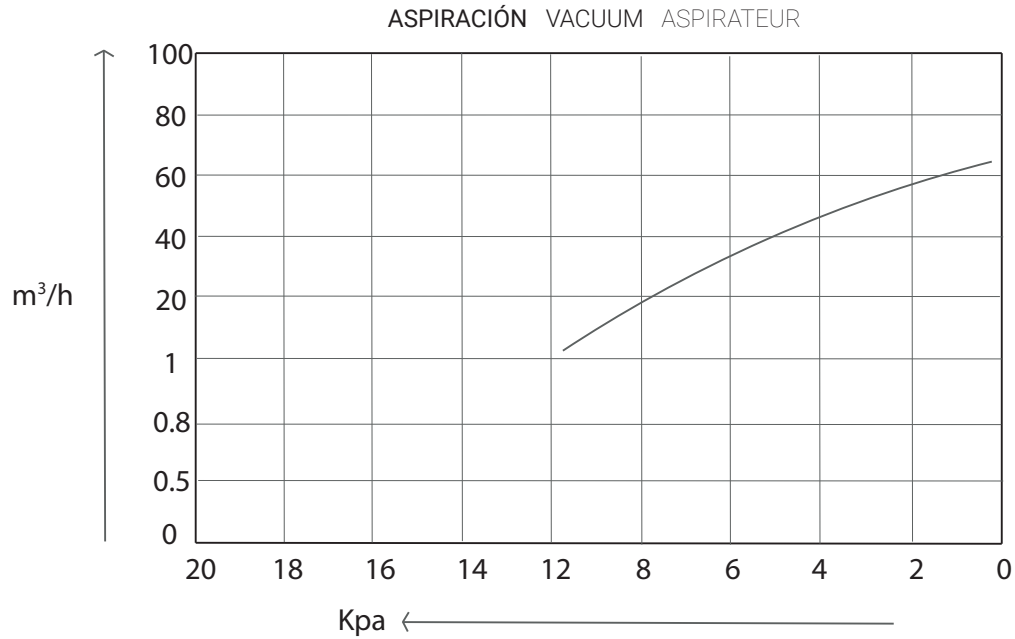

MODELO MODEL MODÈLE	P ₂		VELOCIDAD SPEED VITESSE	Q MAX. m³/h	PRESIÓN MAX. MAX. PRESSURE PRESSION MAX.		NIVEL SONORO NOISE LEVEL NIVEAU DE BRUIT	CONEXIONES CONNECTIONS CONNEXIONS	VOLTAJE VOLTAGE TENSION	INTENSIDAD INTENSITY ^a INTENSITÉ		FRECUENCIA FREQUENCY FRÉQUENCE
	kW	Hp	RPM		Positivo (Kpa)	Negativo (Kpa)				1~230V	3~380V	
BLOW-370	0,37	0,5	2.800	80	16	11	≤60	1-1/4"	220 / 380	2,1 A	0,74 A	50

2. CURVAS CURVES COURBES

BLOW-750

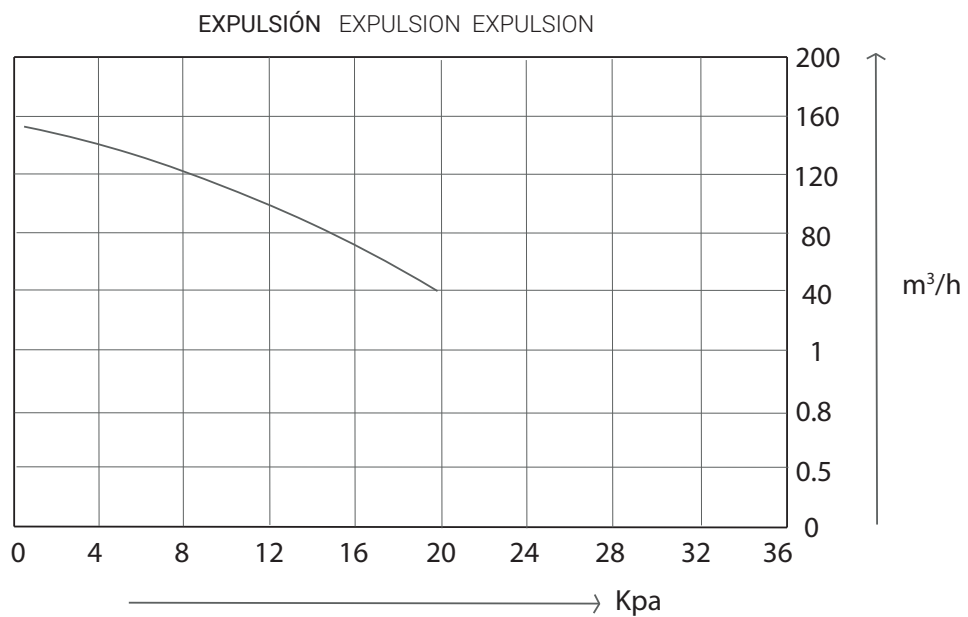
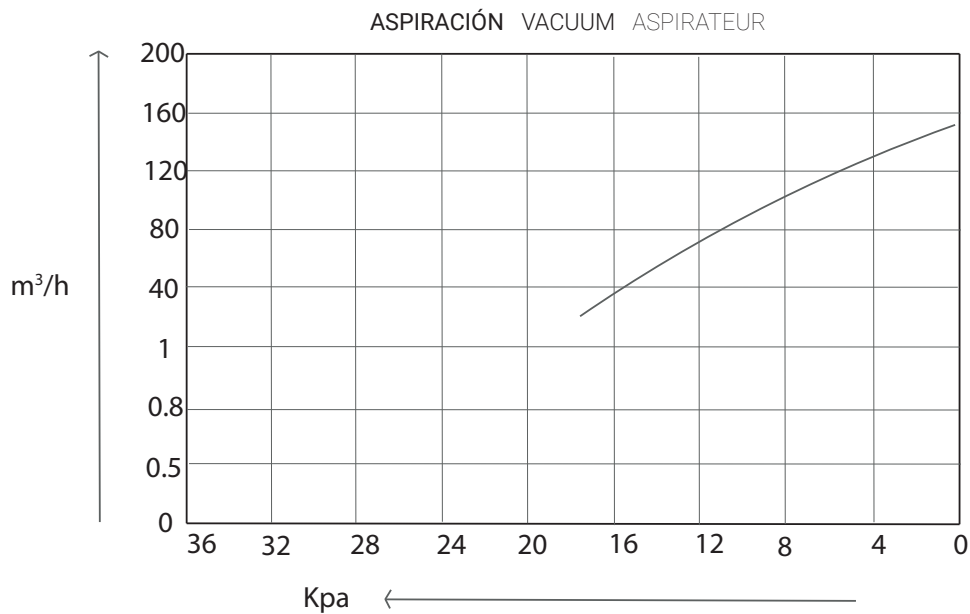

MODELO MODEL MODÈLE	P ₂		VELOCIDAD SPEED VITESSE	Q MAX. m³/h	PRESIÓN MAX. MAX. PRESSURE PRESSION MAX.		NIVEL SONORO NOISE LEVEL NIVEAU DE BRUIT	CONEXIONES CONNECTIONS CONNEXIONS	VOLTAJE VOLTAGE TENSION	INTENSIDAD INTENSITY ^a INTENSITÉ		FRECUENCIA FREQUENCY FRÉQUENCE
	kW	Hp	RPM		Positivo (Kpa)	Negativo (Kpa)				1~230V	3~380V	
BLOW-750	0,75	1,0	2.800	150	22	20	≤60	1-1/2"	220 / 380	4,3	1,5	50

2. CURVAS CURVES COURBES

BLOW-1100

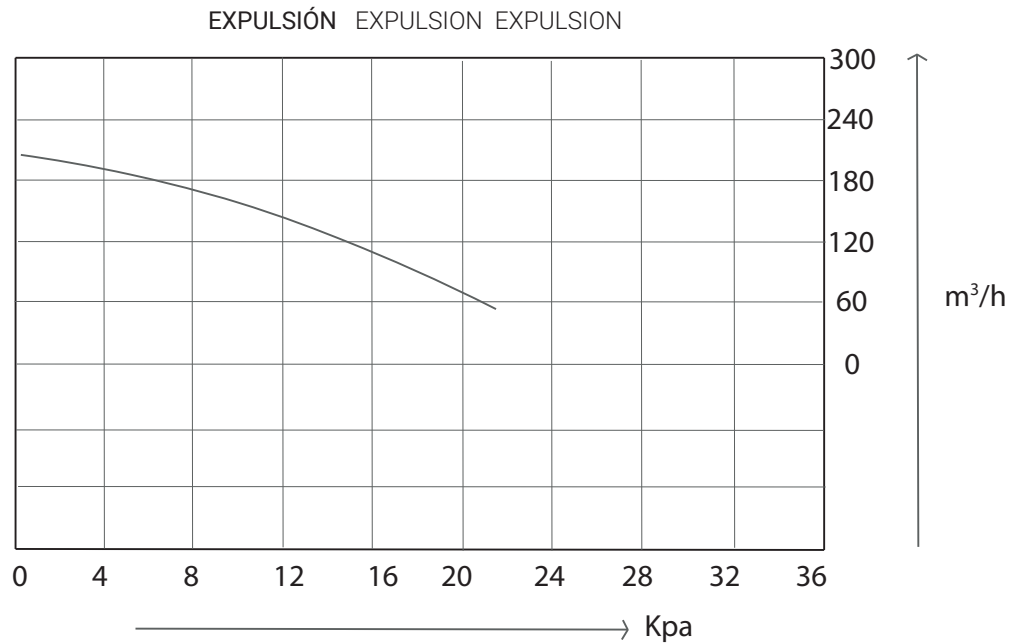
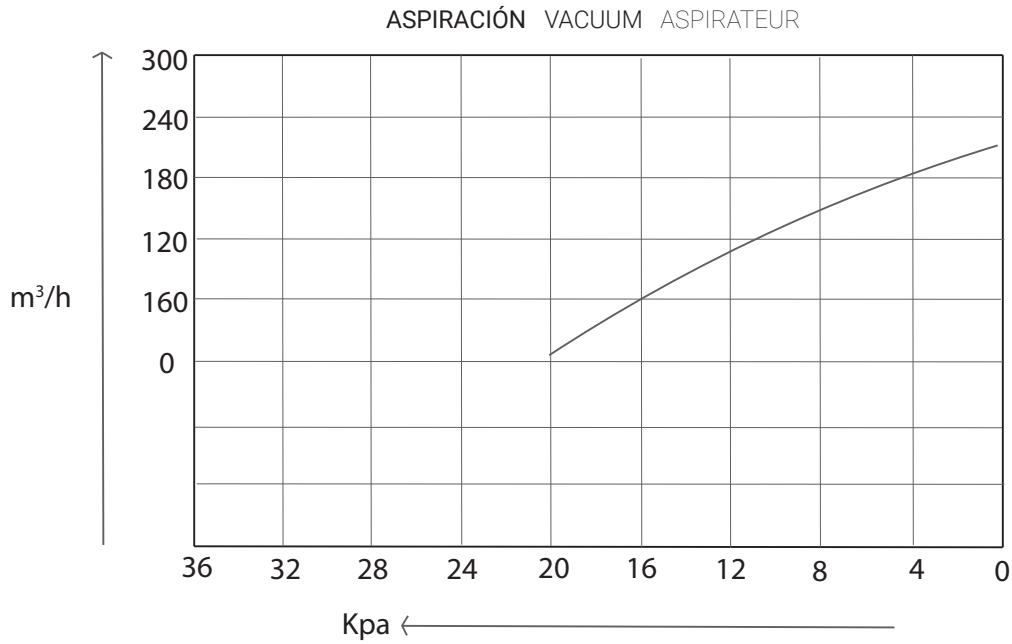

MODELO MODEL MODÈLE	P ₂		VELOCIDAD SPEED VITESSE	Q MAX. m³/h	PRESIÓN MAX. MAX. PRESSURE PRESSION MAX.		NIVEL SONORO NOISE LEVEL NIVEAU DE BRUIT	CONEXIONES CONNECTIONS CONNEXIONS	VOLTAJE VOLTAGE TENSION	INTENSIDAD INTENSITYa INTENSITÉ		FRECUENCIA FREQUENCY FRÉQUENCE
	kW	Hp	RPM		Positivo (Kpa)	Negativo (Kpa)	db	DN	V	1~230V	3~380V	Hz
BLOW-1100	1,1	1,5	2.800	220	25	22	≤60	2"	220 /380	6,2	2,2	50

2. CURVAS CURVES COURBES

BLOW-1500

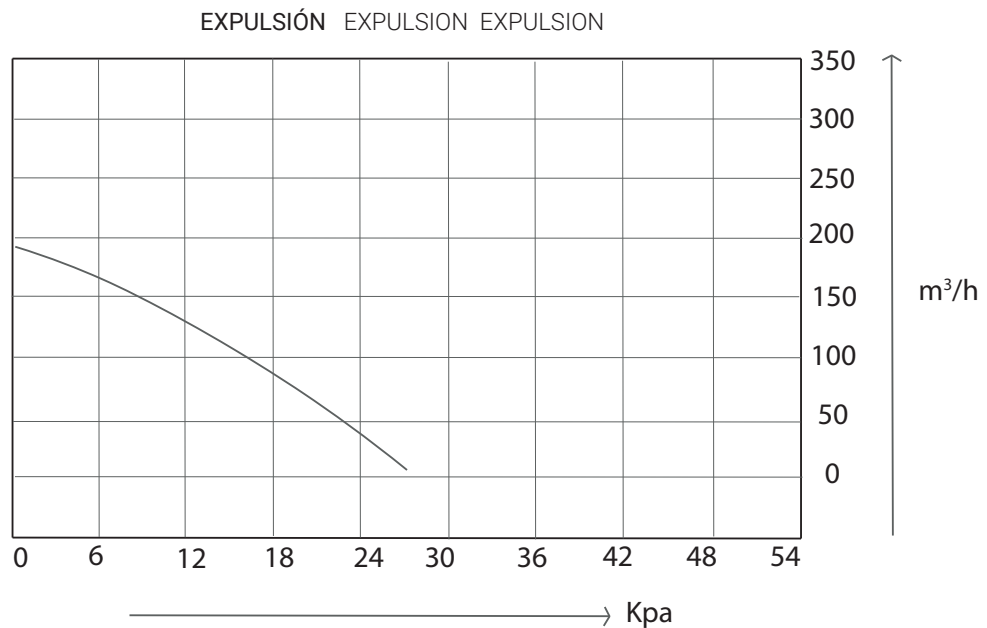
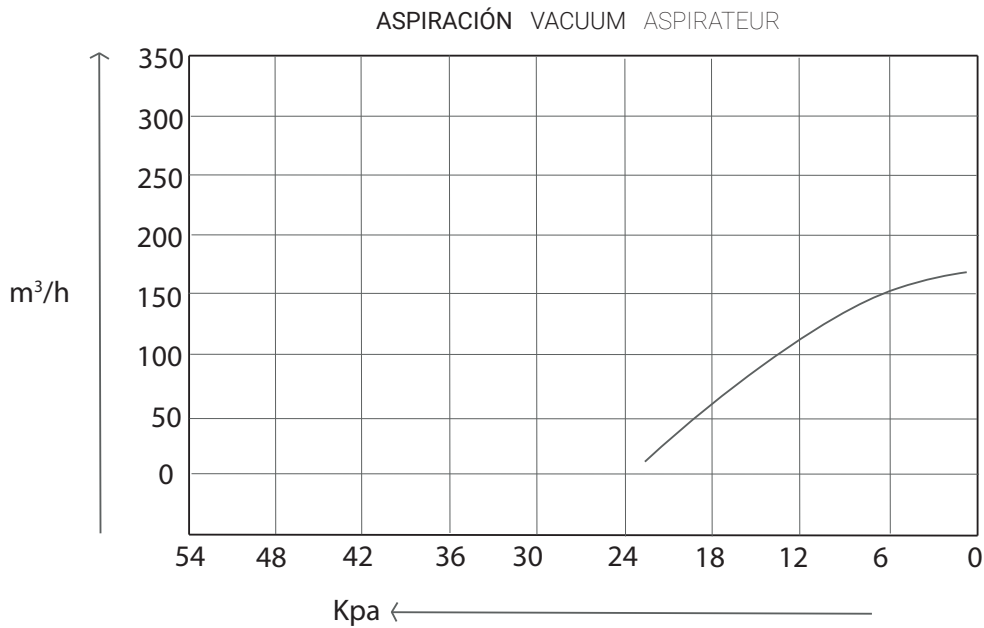

MODELO MODEL MODÈLE	P ₂		VELOCIDAD SPEED VITESSE	Q MAX.	PRESIÓN MAX. MAX. PRESSURE PRESSION MAX.		NIVEL SONORO NOISE LEVEL NIVEAU DE BRUIT	CONEXIONES CONNECTIONS CONNEXIONS	VOLTAJE VOLTAGE TENSION	INTENSIDAD INTENSITY ^a INTENSITÉ		FRECUENCIA FREQUENCY FRÉQUENCE
	kW	Hp	RPM	m³/h	Positivo (Kpa)	Negativo (Kpa)	db	DN	V	1~230V	3~380V	Hz
BLOW-1500	1,5	2,0	2.800	240	27	24	≤60	2"	220 / 380	8,5	3,0	50

2. CURVAS CURVES COURBES

BLOW-2200

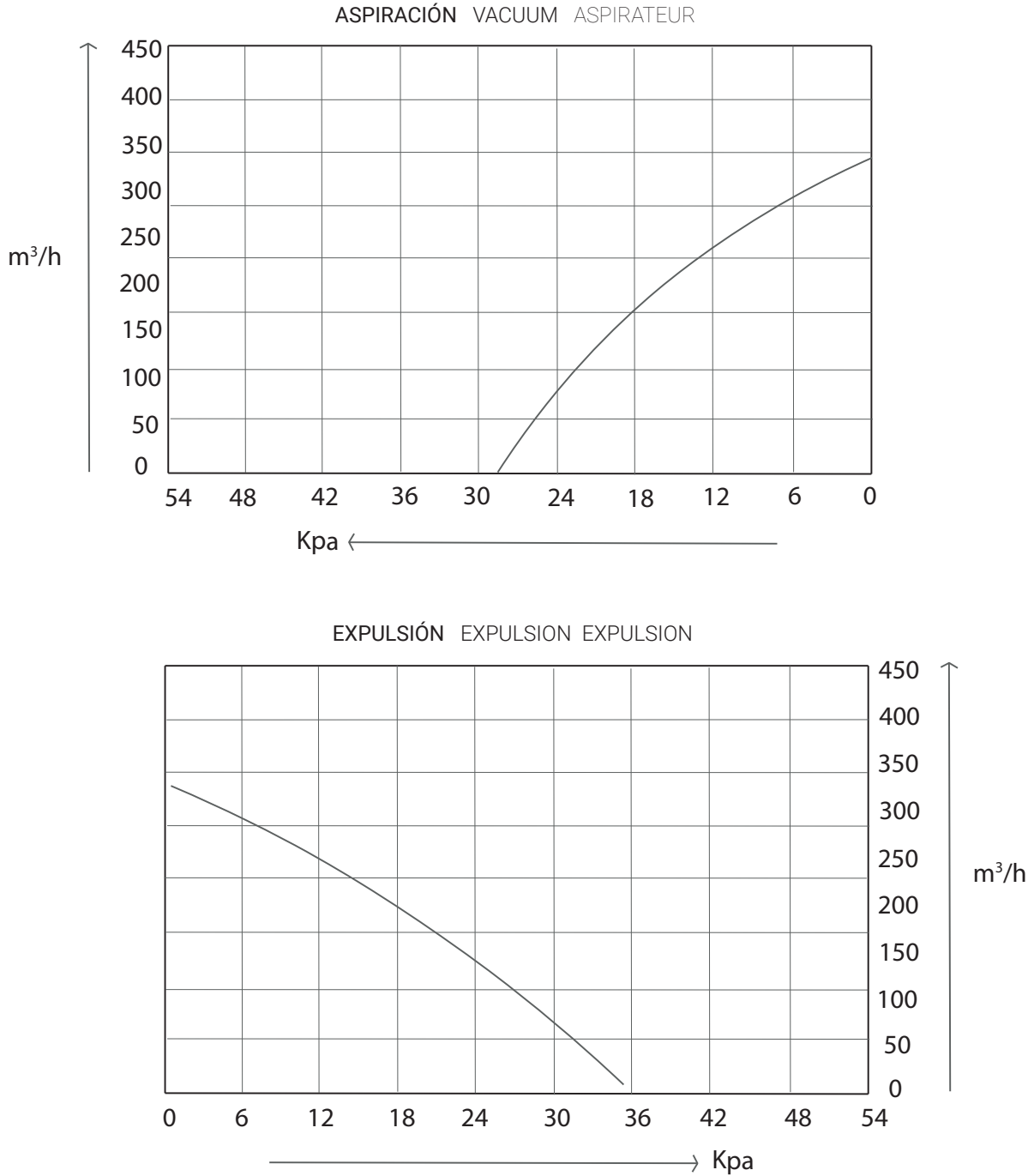

MODELO MODEL MODÈLE	P ₂		VELOCIDAD SPEED VITESSE	Q MAX.	PRESIÓN MAX. MAX. PRESSURE PRESSION MAX.		NIVEL SONORO NOISE LEVEL NIVEAU DE BRUIT	CONEXIONES CONNECTIONS CONNEXIONS	VOLTAJE VOLTAGE TENSION	INTENSIDAD INTENSITY _a INTENSITÉ		FRECUENCIA FREQUENCY FRÉQUENCE
	kW	Hp	RPM	m³/h	Positivo (Kpa)	Negativo (Kpa)	db	DN	V	1~230V	3~380V	Hz
BLOW-2200	2,2	3,0	2.800	325	36	33	≤70	2"	220 / 380	12,5	4,4	50

2. CURVAS CURVES COURBES

BLOW-3000

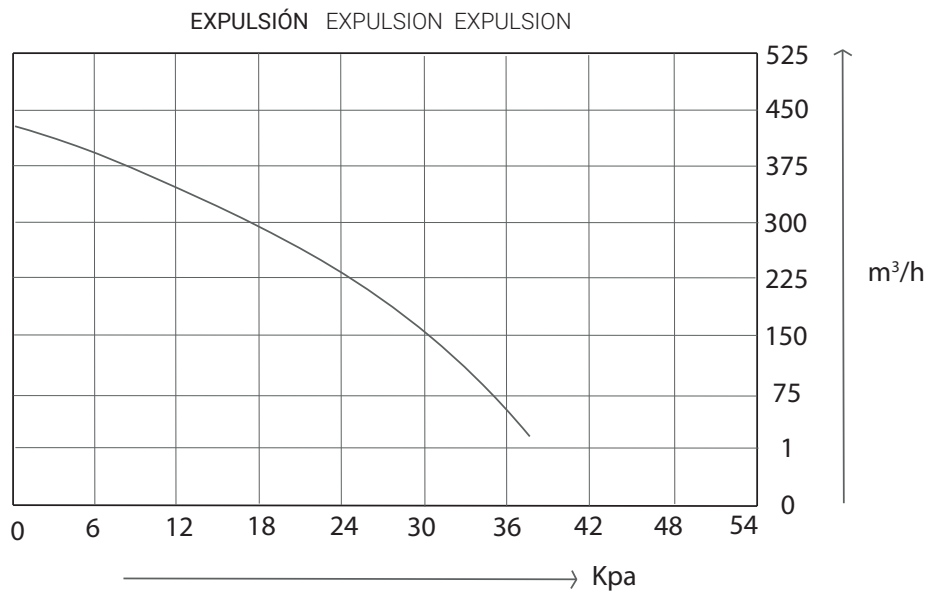
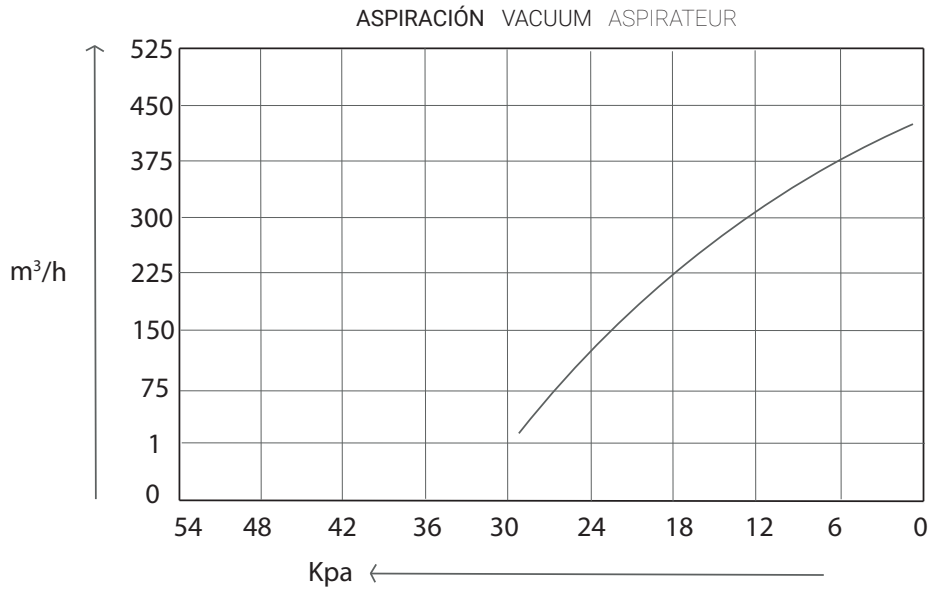

MODELO MODEL MODÈLE	P ₂		VELOCIDAD SPEED VITESSE	Q MAX. m³/h	PRESIÓN MAX. MAX. PRESSURE PRESSION MAX.		NIVEL SONORO NOISE LEVEL NIVEAU DE BRUIT	CONEXIONES CONNECTIONS CONNEXIONS	VOLTAJE VOLTAGE TENSION	INTENSIDAD INTENSITY _a INTENSITÉ	FRECUENCIA FREQUENCY FRÉQUENCE
	kW	Hp	RPM		Positivo (Kpa)	Negativo (Kpa)					
BLOW-3000	3,0	4,0	2.800	390	38	35	≤70	2"	380	6,0	50

2. CURVAS CURVES COURBES

BLOW-4000

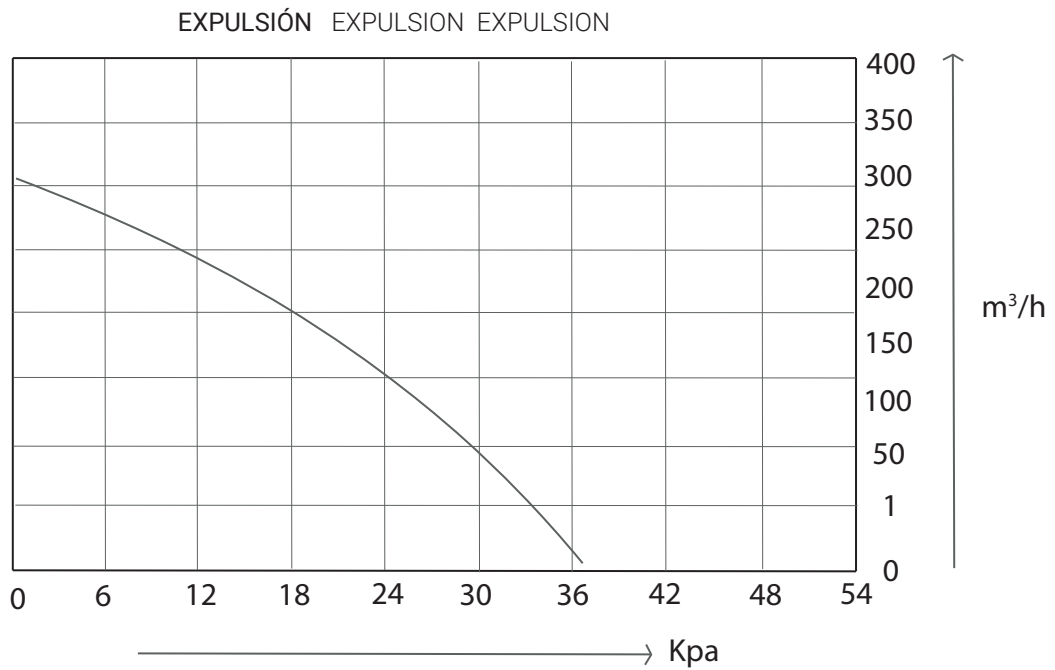
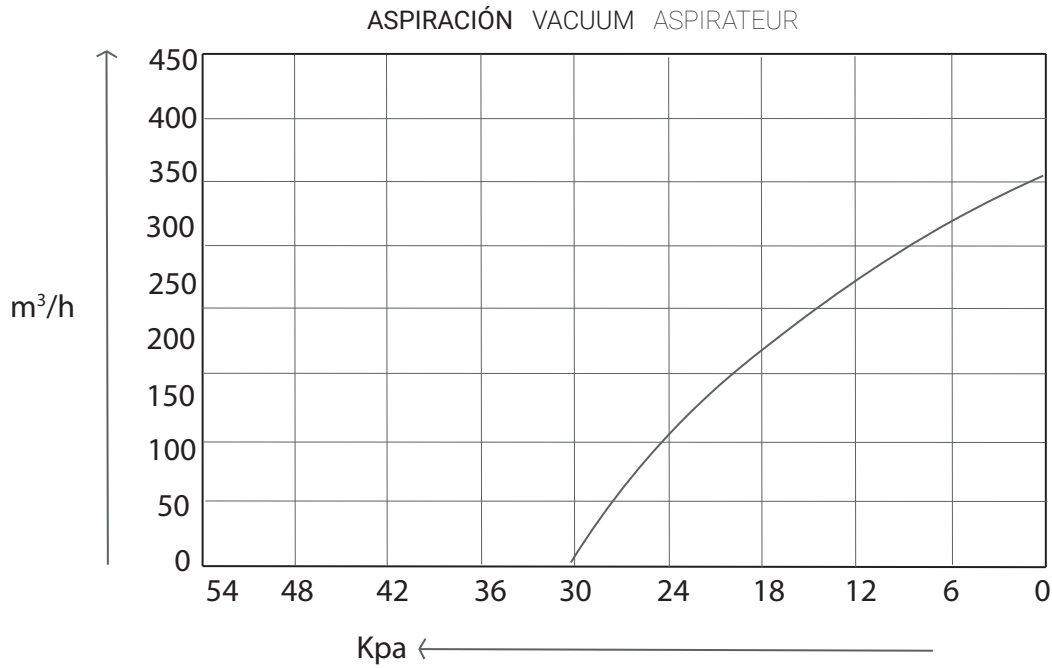

MODELO MODEL MODÈLE	P ₂		VELOCIDAD SPEED VITESSE	Q MAX. m³/h	PRESIÓN MAX. MAX. PRESSURE PRESSION MAX.		NIVEL SONORO NOISE LEVEL NIVEAU DE BRUIT	CONEXIONES CONNECTIONS CONNEXIONS	VOLTAJE VOLTAGE TENSION	INTENSIDAD INTENSITY _a INTENSITÉ	FRECUENCIA FREQUENCY FRÉQUENCE
	kW	Hp	RPM		Positivo (Kpa)	Negativo (Kpa)					
BLOW-4000	4,0	5,4	2.800	480	45	41	≤70	2-1/2"	380	8,0	50

2. CURVAS CURVES COURBES

BLOW-5500

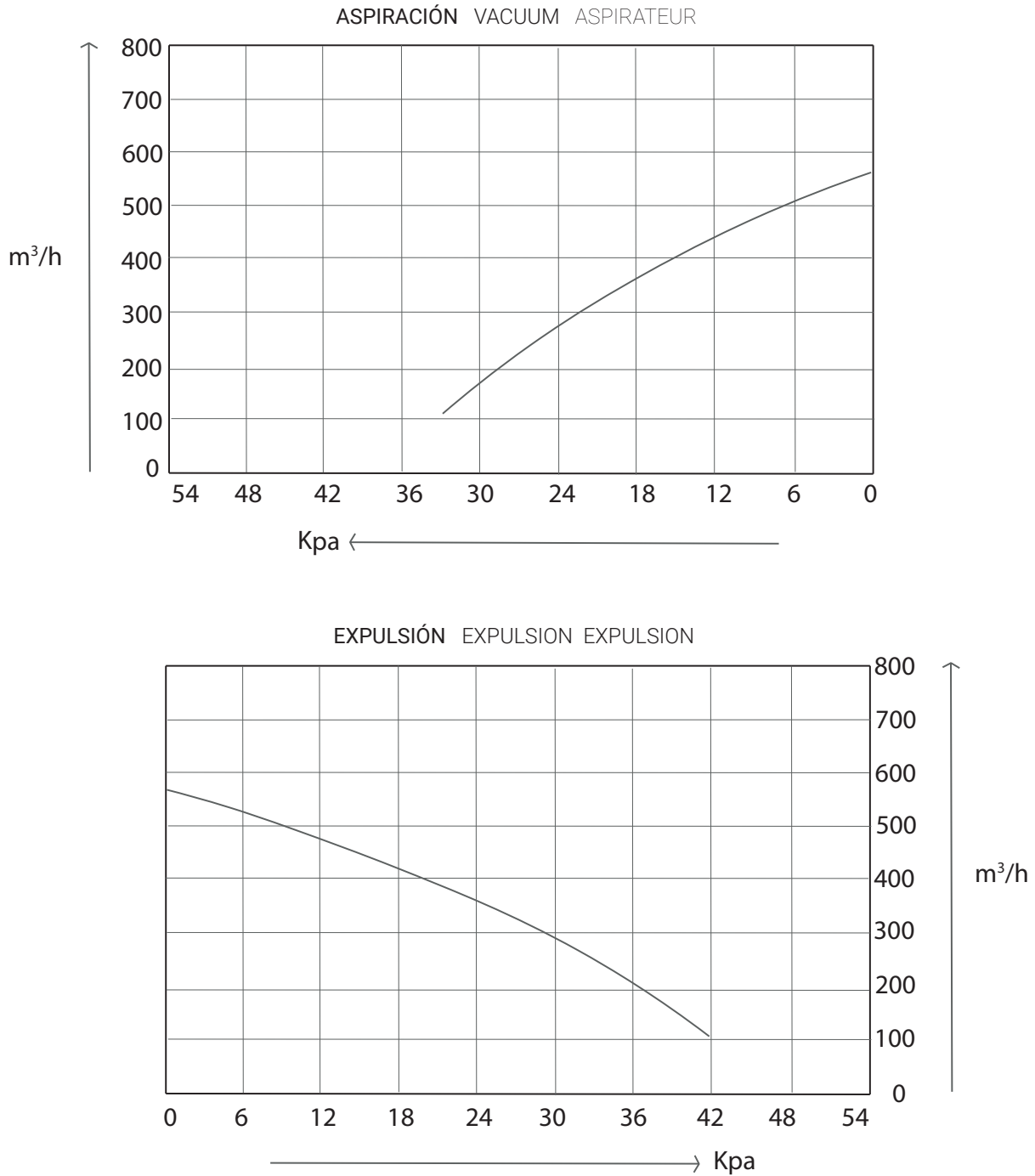

MODELO MODEL MODÈLE	P ₂		VELOCIDAD SPEED VITESSE	Q MAX. m³/h	PRESIÓN MAX. MAX. PRESSURE PRESSION MAX.		NIVEL SONORO NOISE LEVEL NIVEAU DE BRUIT	CONEXIONES CONNECTIONS CONNEXIONS	VOLTAJE VOLTAGE TENSION	INTENSIDAD INTENSITY _a INTENSITÉ	FRECUENCIA FREQUENCY FRÉQUENCE
	kW	Hp	RPM		Positivo (Kpa)	Negativo (Kpa)					
BLOW-5500	5,5	7,4	2.800	530	50	48	≤70	2-1/2"	380	11,0	50

2. CURVAS CURVES COURBES

BLOW-7500

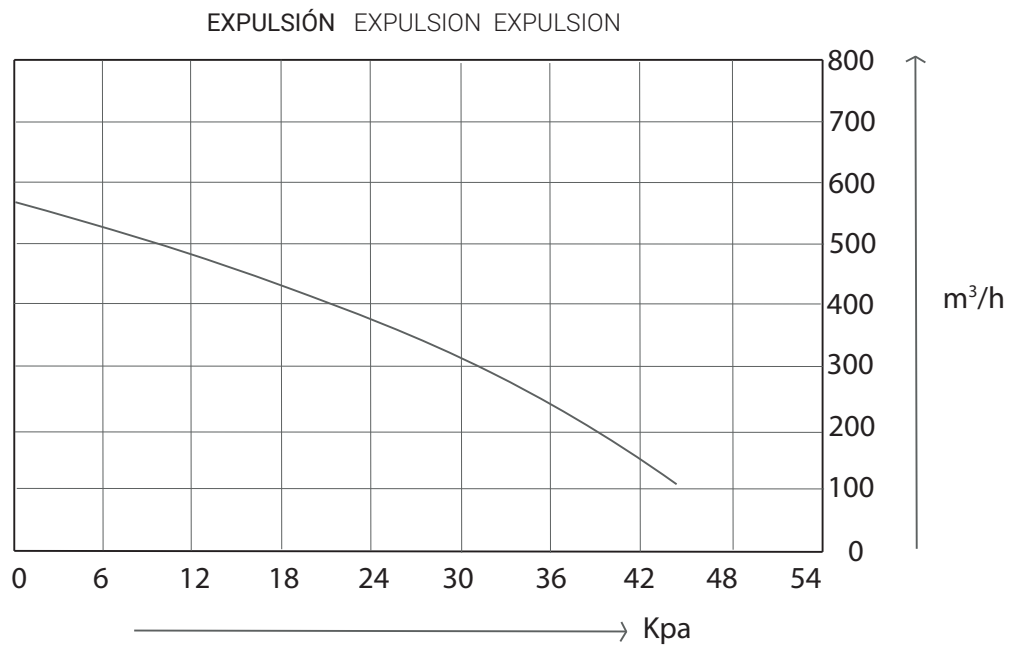
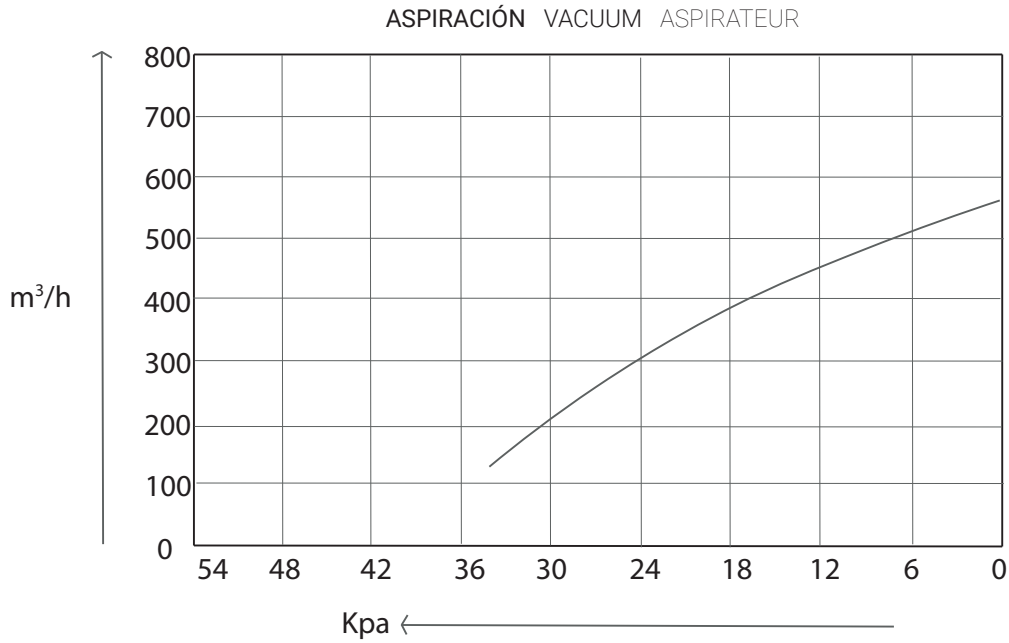

MODELO MODEL MODÈLE	P ₂		VELOCIDAD SPEED VITESSE	Q MAX. m³/h	PRESIÓN MAX. MAX. PRESSURE PRESSION MAX.		NIVEL SONORO NOISE LEVEL NIVEAU DE BRUIT	CONEXIONES CONNECTIONS CONNEXIONS	VOLTAJE VOLTAGE TENSION	INTENSIDAD INTENSITY _a INTENSITÉ	FRECUENCIA FREQUENCY FRÉQUENCE
	kW	Hp	RPM		Positivo (Kpa)	Negativo (Kpa)	db	DN	V	3~380V	Hz
BLOW-7500	7,5	10,0	2.800	550	56	51	≤70	2-1/2"	380	15,0	50

2. CURVAS CURVES COURBES

BLOW-11000

ASPIRACIÓN VACUUM ASPIRATEUR

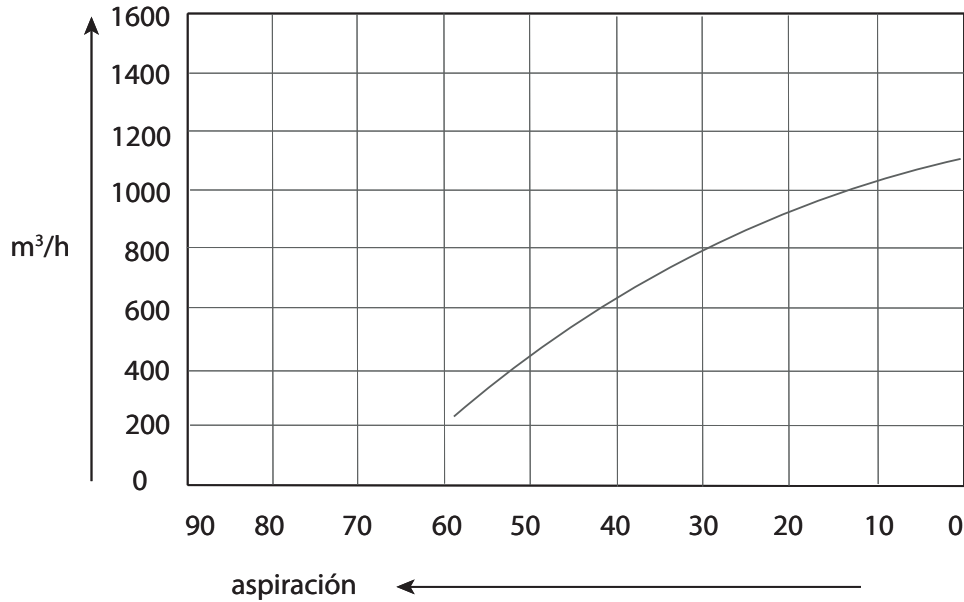

EXPULSIÓN EXPULSION EXPULSION

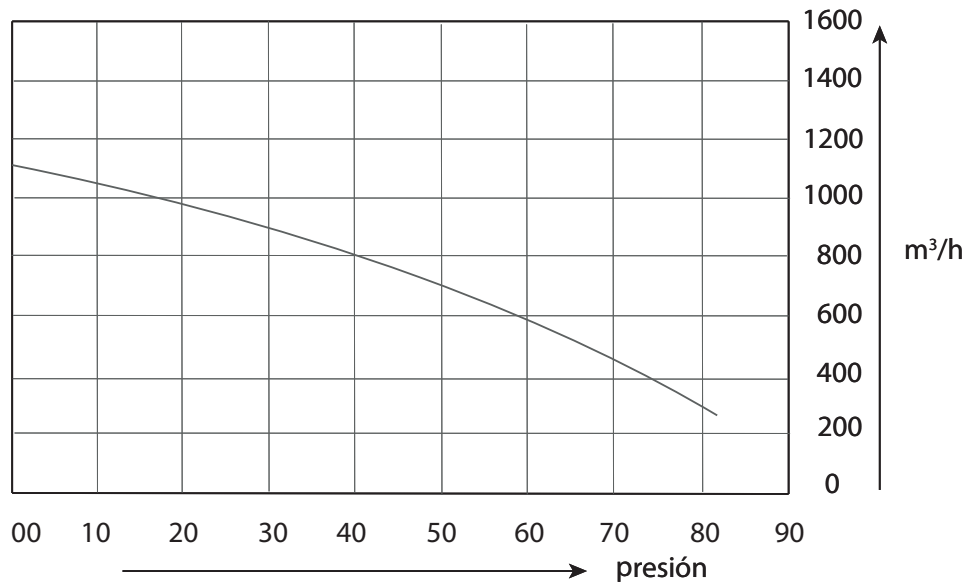

MODELO MODEL MODÈLE	P ₂		VELOCIDAD SPEED VITESSE	Q MAX.	PRESIÓN MAX. MAX. PRESSURE PRESSION MAX.		NIVEL SONORO NOISE LEVEL NIVEAU DE BRUIT	CONEXIONES CONNECTIONS CONNEXIONS	VOLTAJE VOLTAGE TENSION	INTENSIDAD INTENSITY _a INTENSITÉ	FRECUENCIA FREQUENCY FRÉQUENCE
	kW	Hp	RPM	m³/h	Positivo (Kpa)	Negativo (Kpa)	db	DN	V	3~380V	Hz
BLOW-11000	11,0	15,0	2.800	1100	80	56	≤70	4"	380	22,0	50

2. CURVAS CURVES COURBES

BLOW-15000

ASPIRACIÓN VACUUM ASPIRATEUR

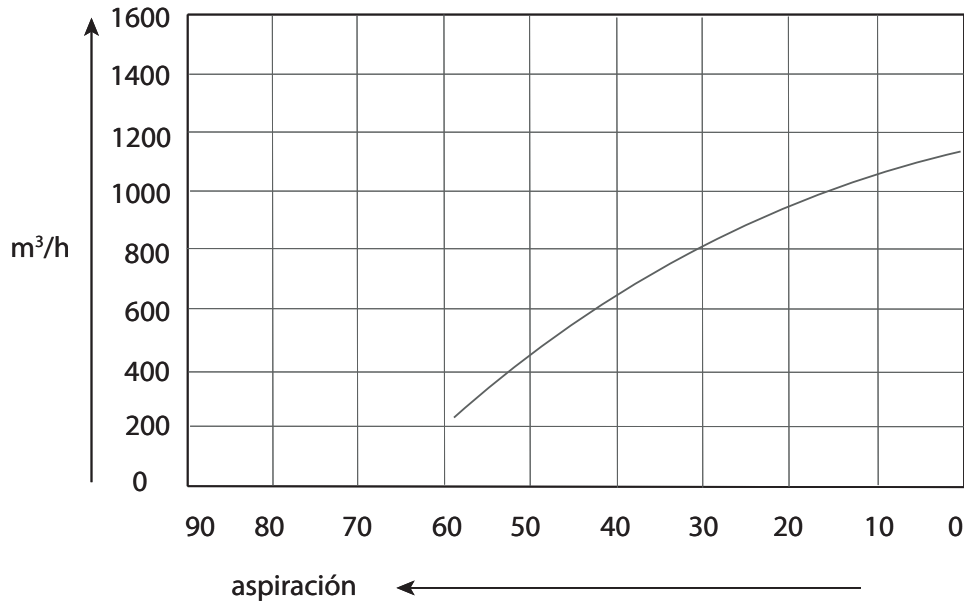

EXPULSIÓN EXPULSION EXPULSION

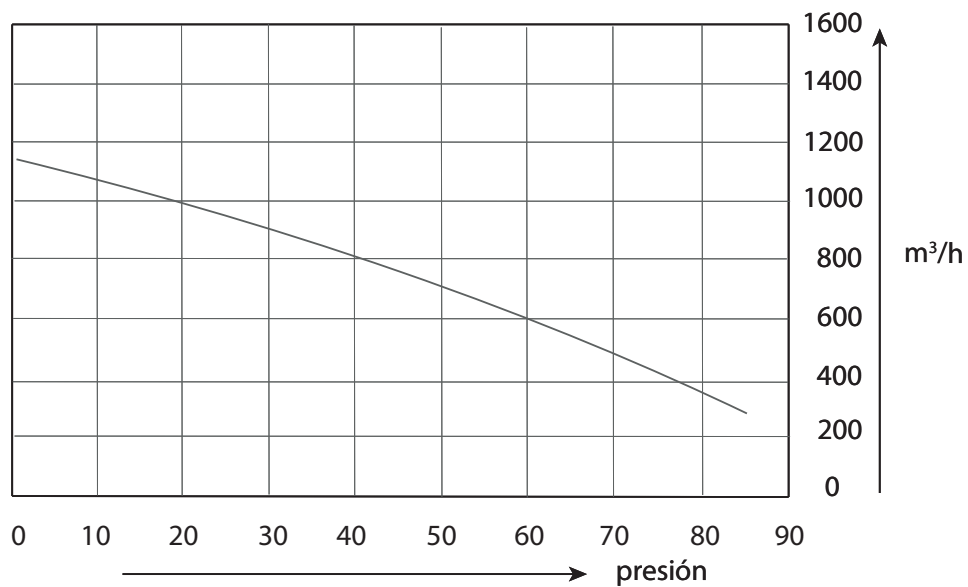

MODELO MODEL MODÈLE	P ₂		VELOCIDAD SPEED VITESSE	Q MAX.	PRESIÓN MAX. MAX. PRESSURE PRESSION MAX.		NIVEL SONORO NOISE LEVEL NIVEAU DE BRUIT	CONEXIONES CONNECTIONS CONNEXIONS	VOLTAJE VOLTAGE TENSION	INTENSIDAD INTENSITY _a INTENSITÉ	FRECUENCIA FREQUENCY FRÉQUENCE
	kW	Hp	RPM	m³/h	Positivo (Kpa)	Negativo (Kpa)	db	DN	V	3~380V	Hz
BLOW-15000	15,0	20,0	2.800	1150	85	58	≤70	4"	380	30,0	50

2. CURVAS CURVES COURBES

BLOW-18500

ASPIRACIÓN VACUUM ASPIRATEUR

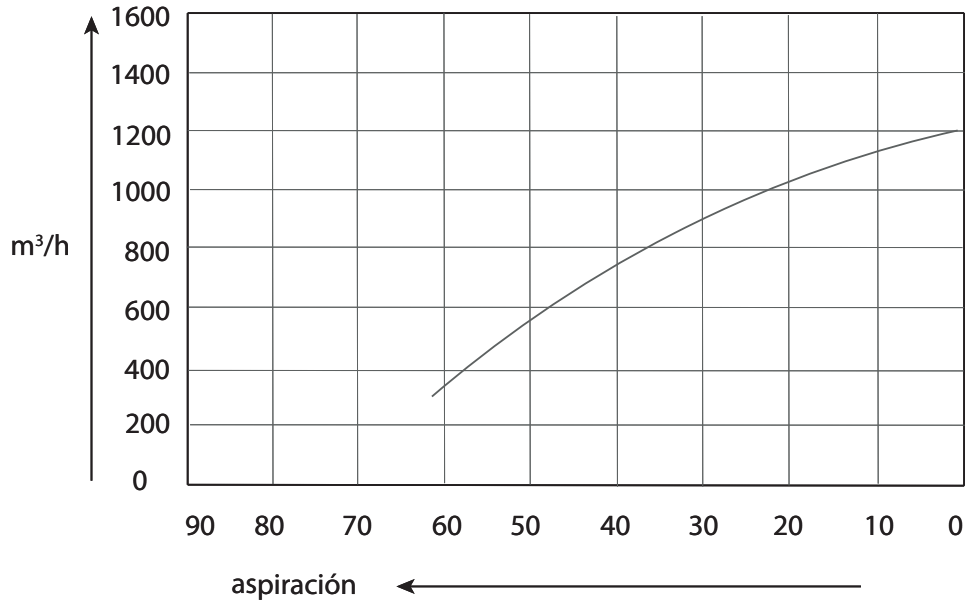

EXPULSIÓN EXPULSION EXPULSION

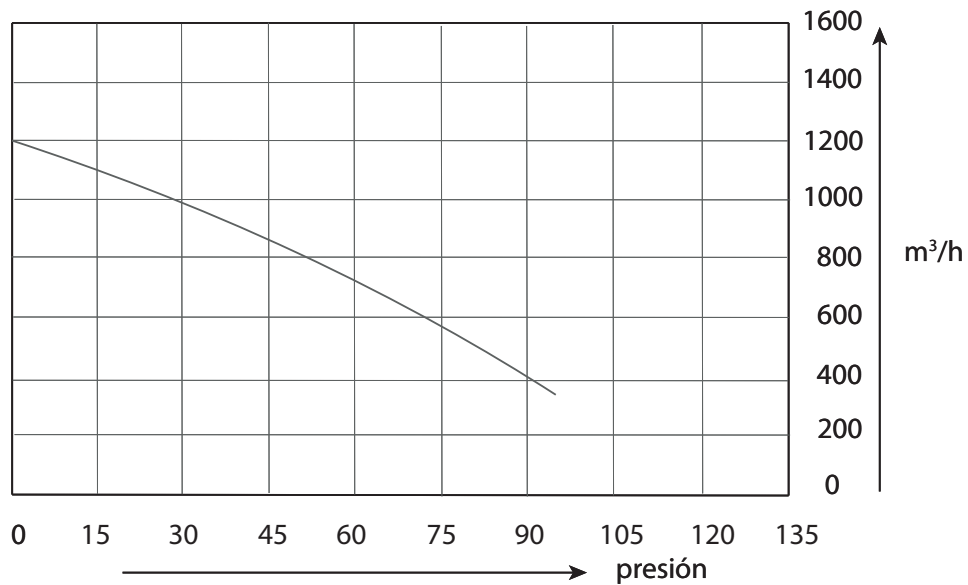

MODELO MODEL MODÈLE	P ₂		VELOCIDAD SPEED VITESSE	Q MAX. m³/h	PRESIÓN MAX. MAX. PRESSURE PRESSION MAX.		NIVEL SONORO NOISE LEVEL NIVEAU DE BRUIT	CONEXIONES CONNECTIONS CONNEXIONS	VOLTAJE VOLTAGE TENSION	INTENSIDAD INTENSITY _a INTENSITÉ	FRECUENCIA FREQUENCY FRÉQUENCE
	kW	Hp	RPM		Positivo (Kpa)	Negativo (Kpa)					
BLOW-18500	18,5	25,0	2.800	1200	90	60	≤70	4"	380	37,0	50

3. CONEXIONES CONNECTIONS CONNEXIONS

Modelos:

- BLOW-370
- BLOW-750



Conector
Connector
Connecteur

Modelos:

- BLOW-1100
- BLOW-1500
- BLOW-2200
- BLOW-3000
- BLOW-4000
- BLOW-5500
- BLOW-7500



Brida
Flange
Bride

Conector
Connector
Connecteur

Modelos:

- BLOW-11000
- BLOW-15000
- BLOW-18500



Conexión de brida
Flange connection
Bride connecteur

4. MEDIDAS MEASURES MESURES

BLOW-370

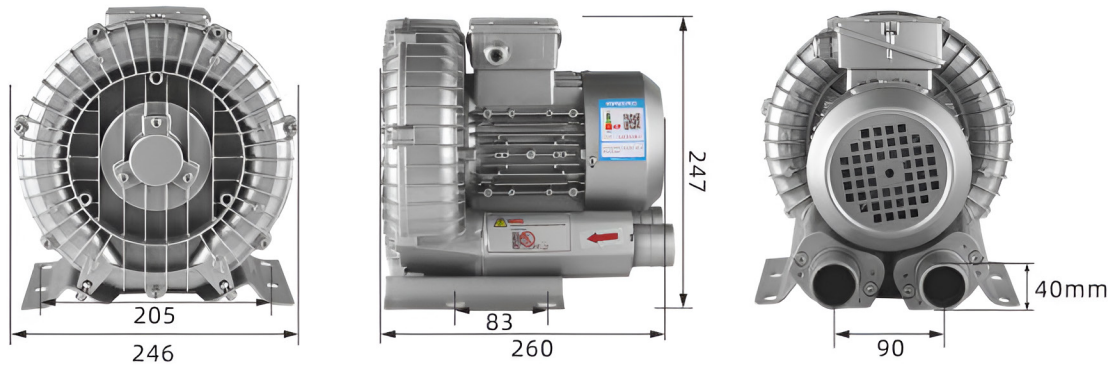

BLOW-750

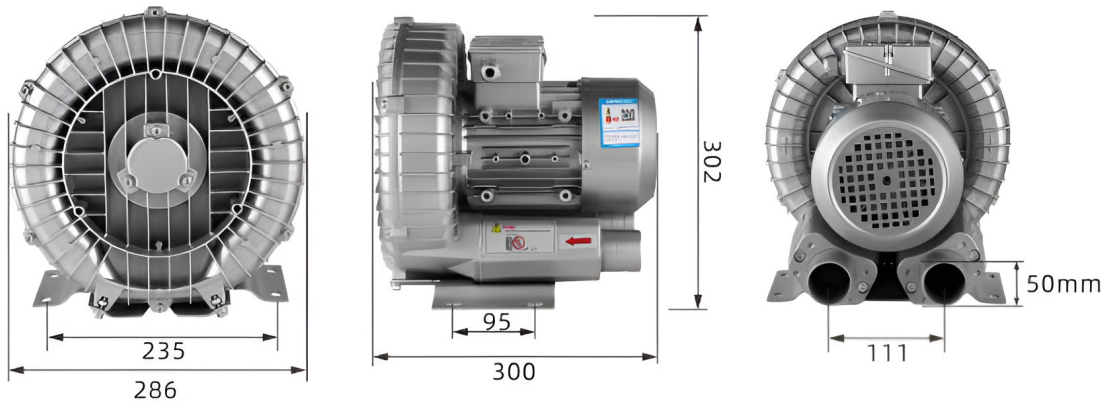

BLOW-1100

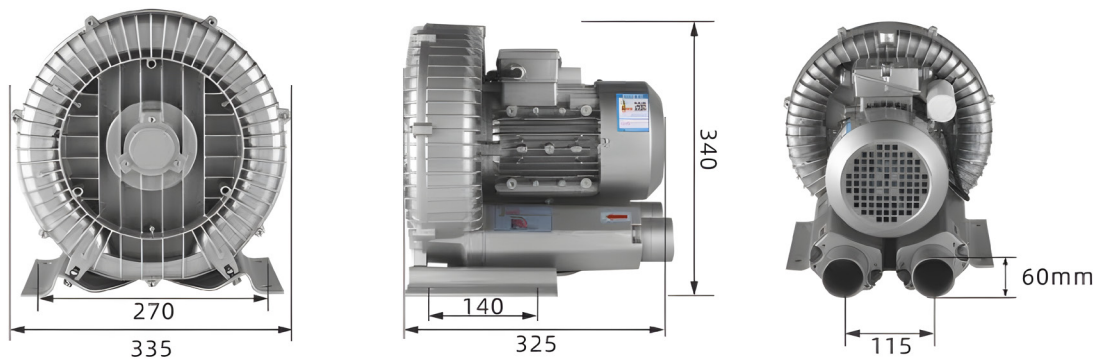

BLOW-1500

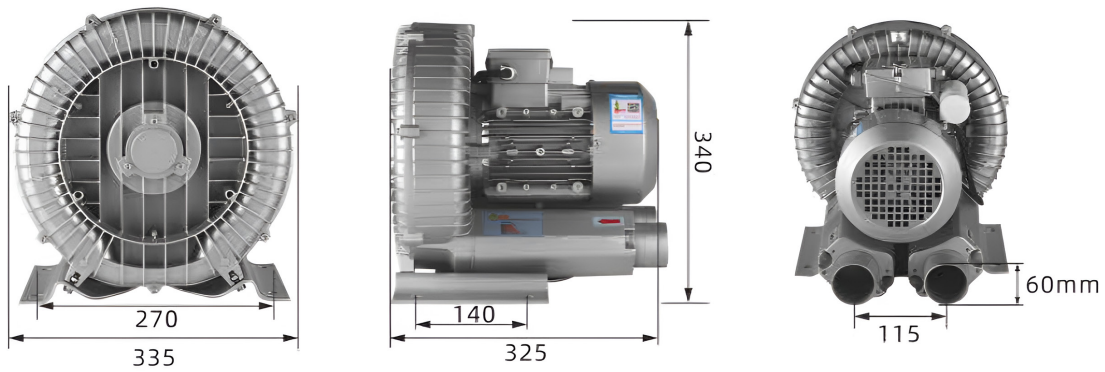

BLOW-2200

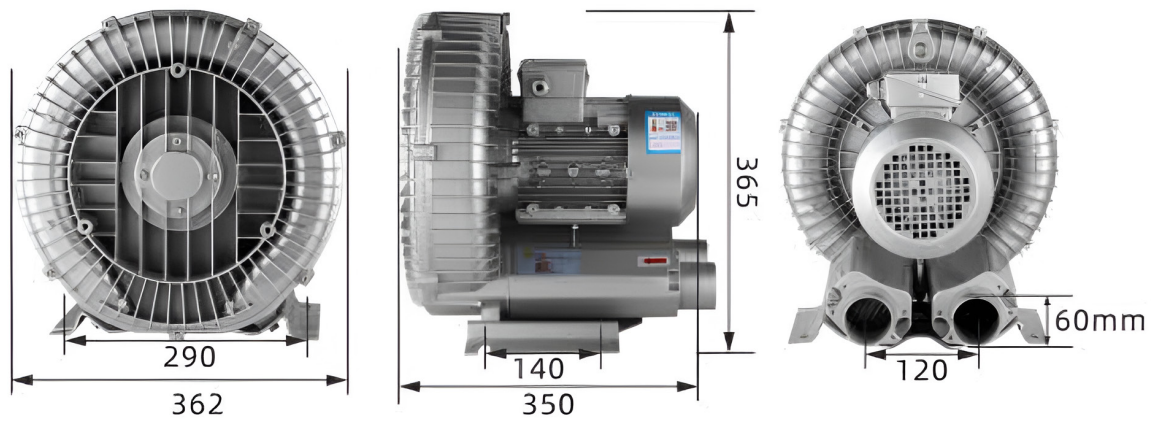

BLOW-3000

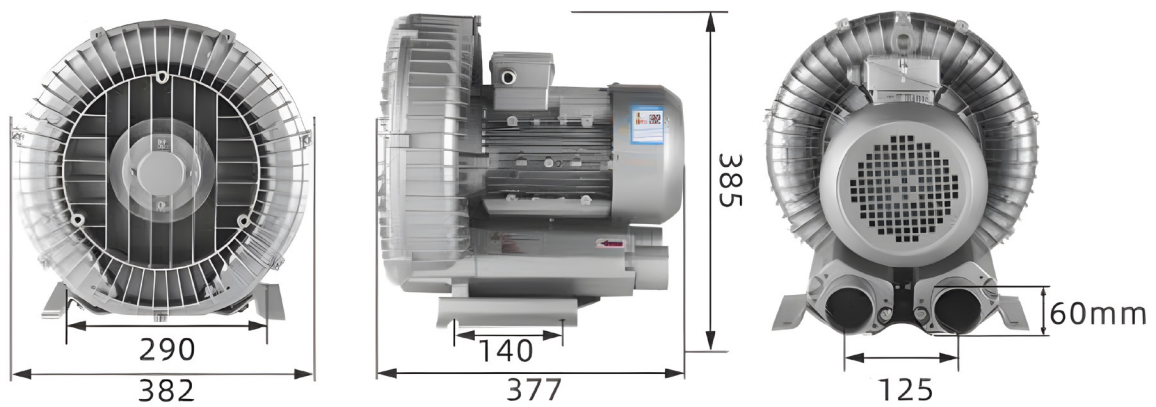

BLOW-4000

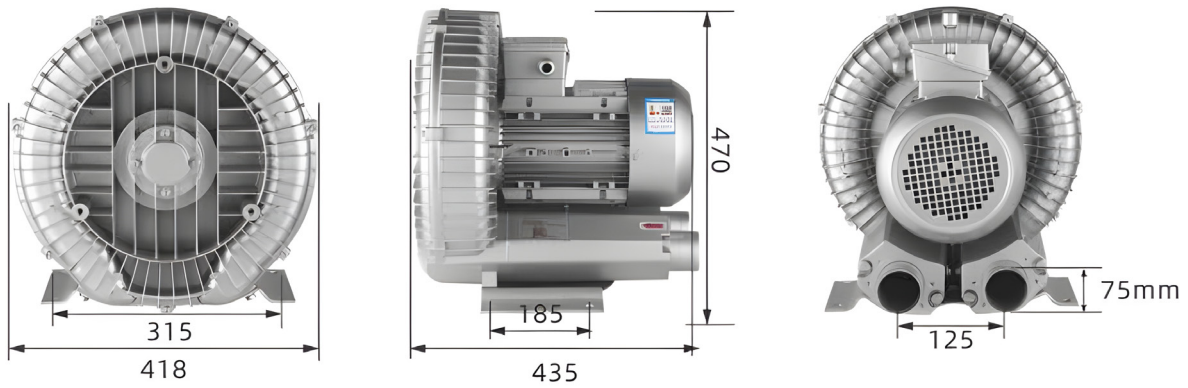

BLOW-5500

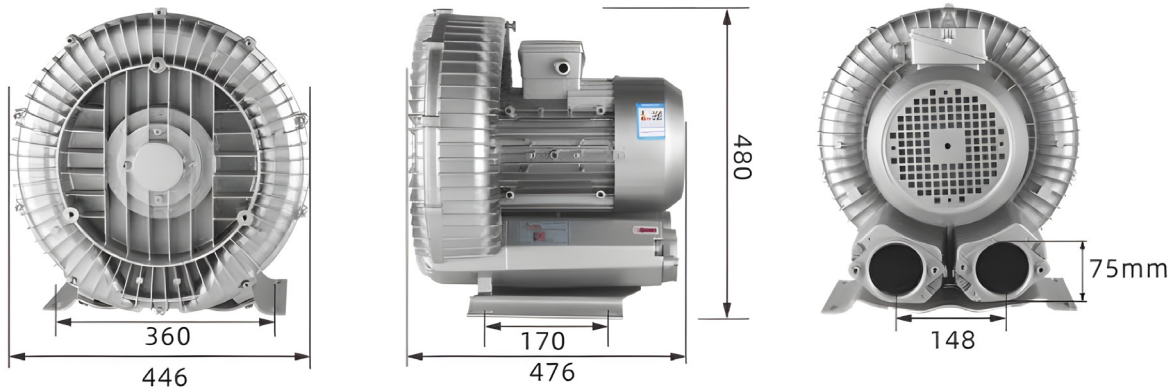

BLOW-7500

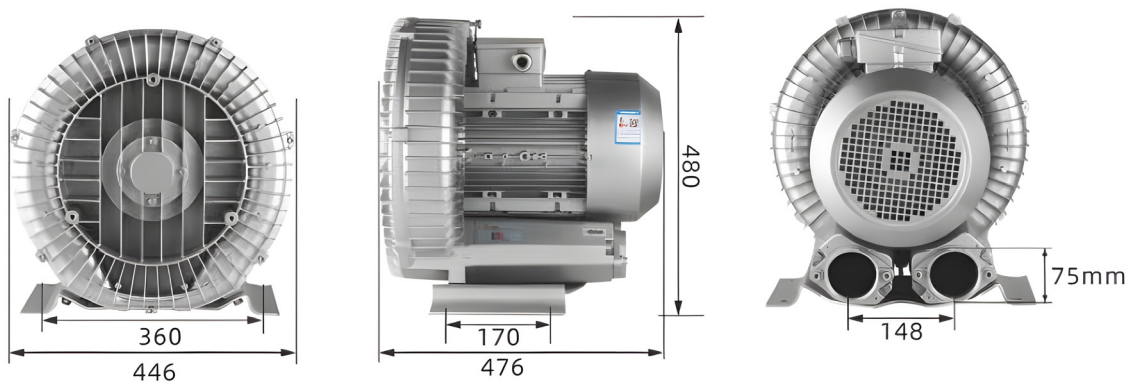

BLOW-11000

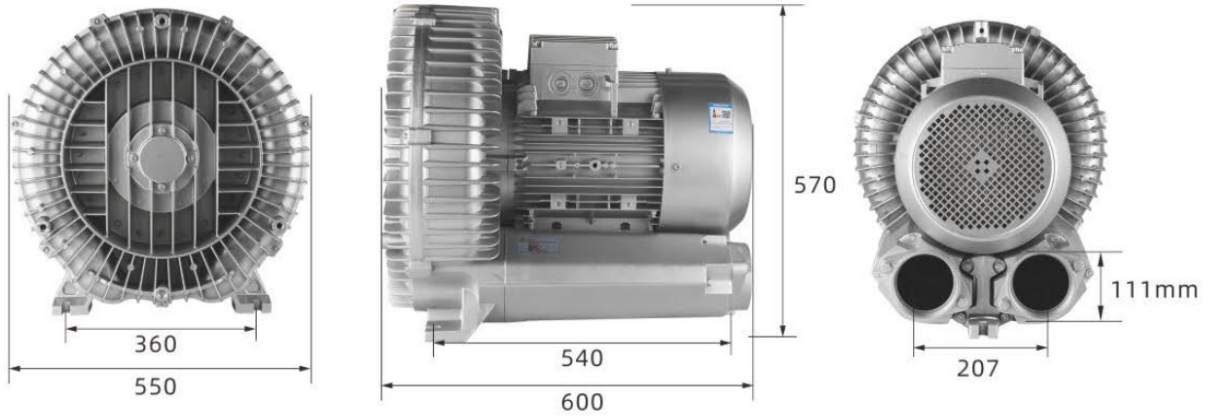

BLOW-15000

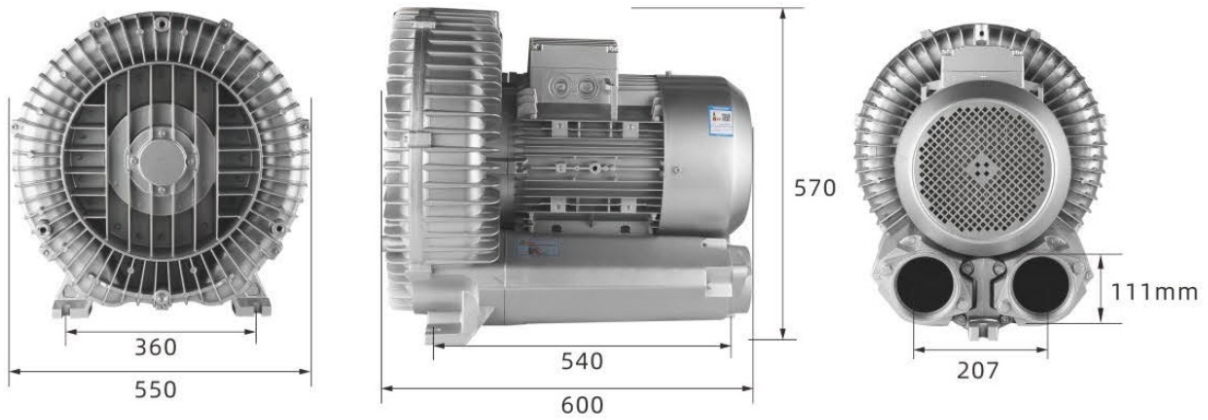

BLOW-18500

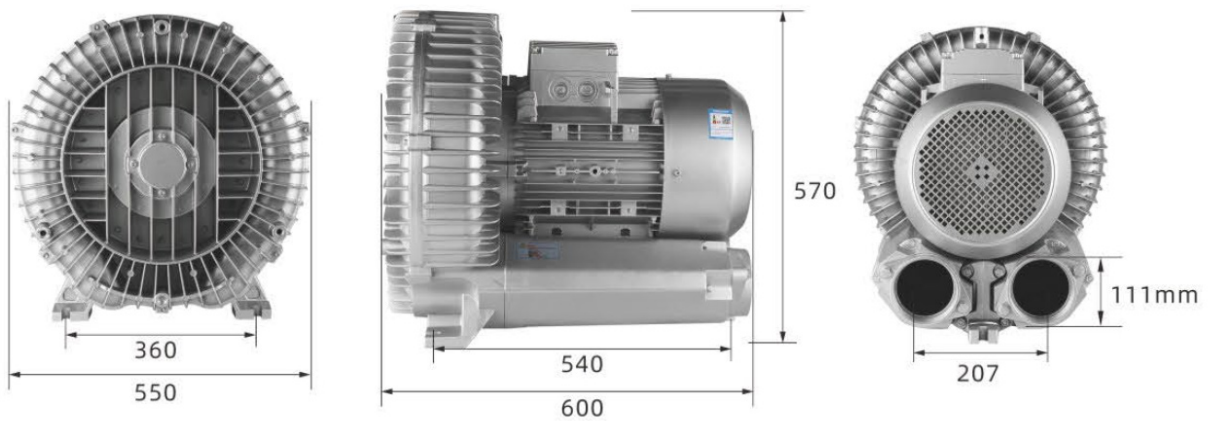

5. DESPIECE SPARE PARTS PIÈCES DE RECHANGE

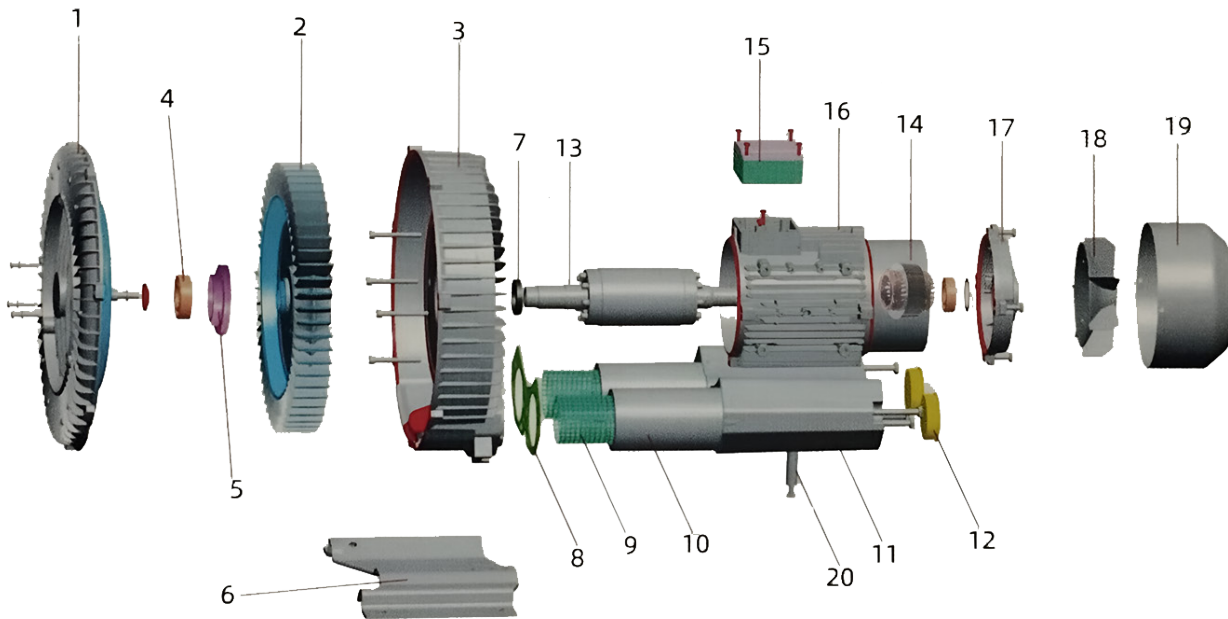

Nº	Nombre	Name	Nom
1	Cobertura de la bomba	Pump cover	Couvercle de la pompe
2	Impulsor	Impeller	Roue
3	Cuerpo de la bomba	Pump body	Corps de pompe
4	Rodamiento	Bearing	Palier
5	Asiento del rodamiento	Bearing seat	Siège du palier
6	Placa base	Base plate	Plaque de base
7	Sello de aceite	Oil seal	Joint d'huile
8	Junta	Gasket	Joint d'étanchéité
9	Red silenciadora	Silencer net	Filet de silencieux
10	Esponja silenciadora	Silencer sponge	Éponge pour silencieux
11	Tubería silenciadora	Silencer pipe	Tuyau de silencieux
12	Conector (brida)	Connector (flange)	Connecteur (bride)
13	Rotor	Rotor	Rotor
14	Motor	Motor	Moteur
15	Caja de bornes	Terminal box	Boîte à bornes
16	Carcasa del motor	Motor housing	Boîtier du moteur
17	Tapa final del motor	Motor end cover	Couvercle d'extrémité du moteur
18	Ventilador del motor	Motor fan	Ventilateur du moteur
19	Cubierta trasera del motor	Motor back cover	Couvercle arrière du moteur
20	Tubo de soporte	Supporting tube	Tube de support

Proindecsa

C/ Paraguay, parc. 13-5/6
Polígono industrial Oeste
30820 Alcantarilla, Murcia (Spain)

Tel. : +34 968 880 852
proindecsa@proindecsa.com

www.proindecsa.com



🇪🇸 Proindecsa S.L. no se hace responsable de los posibles errores u omisiones que pueda contener este catálogo, ni de los daños o perjuicios que puedan derivarse de su uso. Proindecsa S.L. se reserva el derecho de modificar o actualizar el contenido de este catálogo en cualquier momento y sin previo aviso.

✳️ Proindecsa S.L. shall not be liable for any errors or omissions that this catalogue may contain, nor for any damages that may arise from its use. Proindecsa S.L. reserves the right to modify or update the contents of this catalogue at any time and without prior notice.

